

**G**lenair®



# Series 28 HiPer-D Connectors and Accessories

*The High-Performance D-Subminiature for  
Extreme Land, Air and Space Applications*

United States ■ United Kingdom ■ Germany ■ France ■ Nordic ■ Italy ■ Spain ■ Japan

First Edition • August 2011



SERIES 28

# HiPer-D

MIL-DTL-24308 INTERMATEABLE AND INTERMOUNTABLE



## Bringing 21<sup>st</sup> Century Technology to the World's Most Popular Connector Interface

### The *Extreme Duty* D-Sub Connector

Meet the Series 28 HiPer-D. Intermateable and intermountable with standard M24308 type D-Subs, the HiPer-D meets the need for improved performance in hostile environments. Unlike standard M24308 connectors with stamped steel shells, the HiPer-D is machined from aluminum or stainless steel. The dielectric inserts are made with thermoset epoxy for unbeatable resistance to chemicals and are capable of 200°C continuous operating temperature. Aerospace grade fluorosilicone grommets and face seals provide watertight sealing. Integrated grounding fingers provide advanced electromagnetic compatibility. Best of all, the HiPer-D is available in every standard and high-density M24308 layout and is stocked for immediate same-day shipment.



# Series 28 HiPer-D Connectors and Accessories Table of Contents



Intro

A

B

C

D

E

F

G

H

Index

## Introduction to the HiPer-D Connector

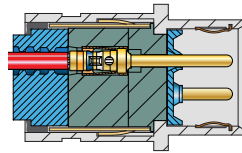

HiPer-D Product Facts..... A-2  
Connector Selection Guide..... A-3

## General information and Reference

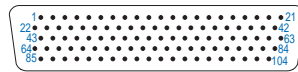

Contact Arrangements ..... B-1  
Product Specifications Summary..... B-1  
Shell Material and Finish Options..... B-2  
Product Specifications ..... B-3  
Space Flight information..... B-6

## Contacts and Tools



Crimp Contacts ..... C-2  
Crimp Tools..... C-4  
Insertion/Extraction Tools ..... C-4  
Band-Master™ Advanced Termination System ..... C-5

## Cable Connectors



Pin Connector 280-018P ..... D-1  
Socket Connector 280-019S ..... D-3

## Panel Mount Connectors *Crimp Termination*



Panel Mount Pin Connector 280-020P ..... E-1  
Float Mount Pin Connector 280-030P ..... E-4  
Panel Mount Socket Connector 280-021S ..... E-7  
Float Mount Socket Connector 280-031S ..... E-10

## Straight PCB Connectors



Panel Mount PCB Pin Connector 280-022P ..... F-1  
Free-Standing PCB Pin Connector 280-026P ..... F-4  
Panel Mount PCB Socket Connector 280-023S..... F-11  
Free-Standing PCB Socket Connector 280-027S ... F-14

## Right Angle PCB Connectors



Panel Mount PCB Pin Connector 280-024P ..... G-1  
Free-Standing PCB Pin Connector 280-028P ..... G-4  
Panel Mount PCB Socket Connector 280-025S..... G-11  
Free-Standing PCB Socket Connector 280-029S ... G-14

## Connector Backshells and Accessories



Protective Covers ..... H-1  
Low Profile EMI backshell 289-005 ..... H-3  
Environmental EMI Backshell 289-008..... H-6  
Adapter for Panel Mount Connector 289-007 ..... H-9  
Jackpost Kits 289-015, 289-016 ..... H-13  
Sav-Con® HiPer-D Connector Saver 280-012 ..... H-15

## Part Number index

Dimensions in inches (millimeters) and are subject to change without notice.  
CAGE Code 06324

## The Advanced D-Sub Connector for Reliable Performance in Hostile Environments

### Product Features

- Environmental, crimp removable rectangular connector
- Advanced temperature, vibration and EMC/electrical performance
- M24308/D-Sub intermateable
- Fits panel and PCB footprint of M24308/D-Sub products
- Available in all 11 "standard" insert arrangements
- Standard Density (#20) and High Density (#22D)
- EMI spring
- High temperature thermoset epoxy insulators
- Watertight sealing
- Rugged machined one-piece shell
- Optional guide pins for blind mating



### Available configurations

- Crimp termination for attaching wire or cable: Standard cable, rear panel mount and float mount
- Printed circuit board termination for rear panel mounting: Straight and right angle
- Free-standing printed circuit board termination: Straight and right angle

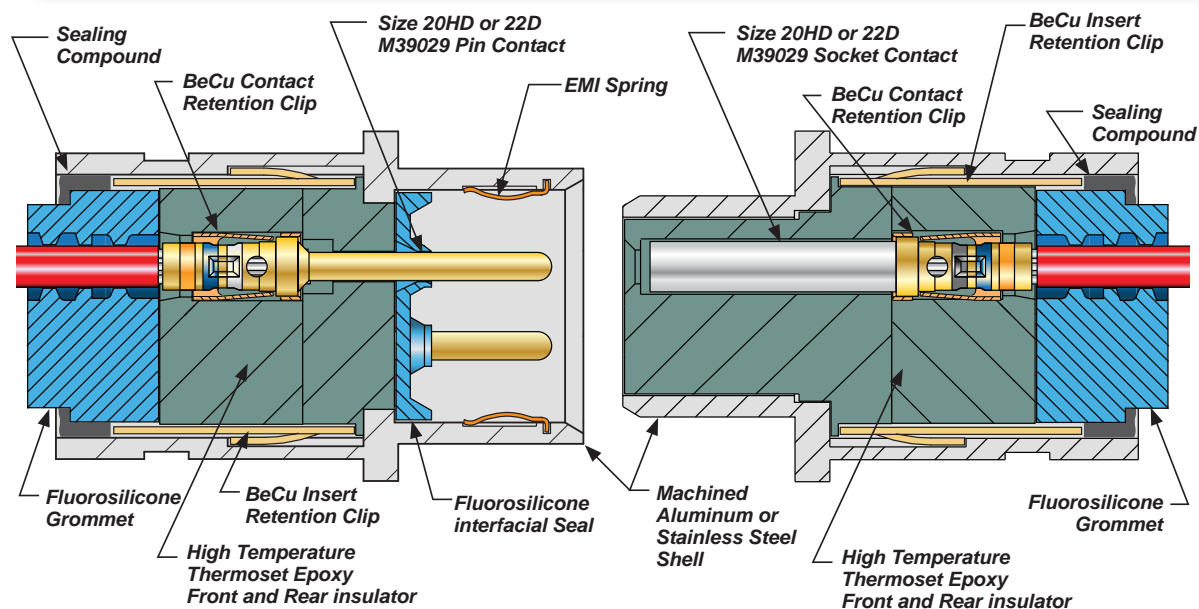

Dimensions in inches (millimeters) and are subject to change without notice.

## HiPer-D Connector Selection Guide

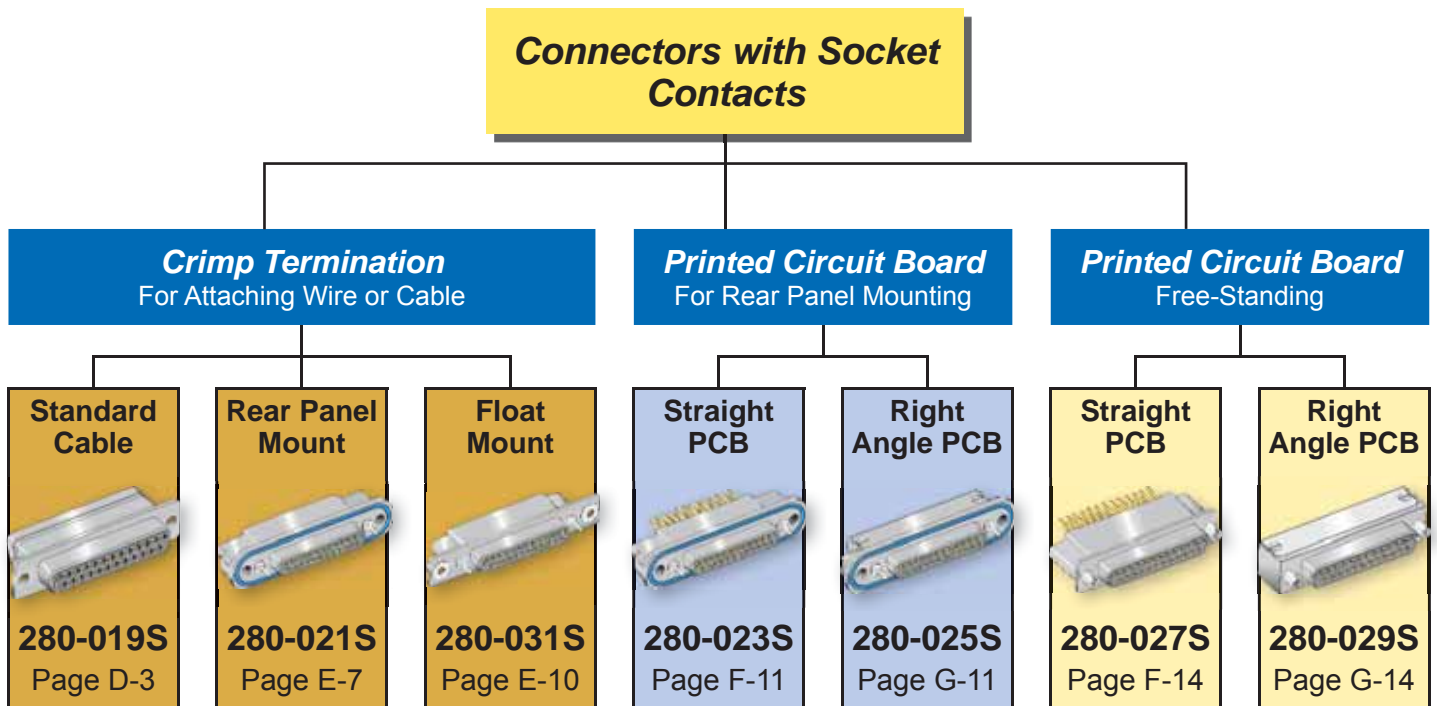
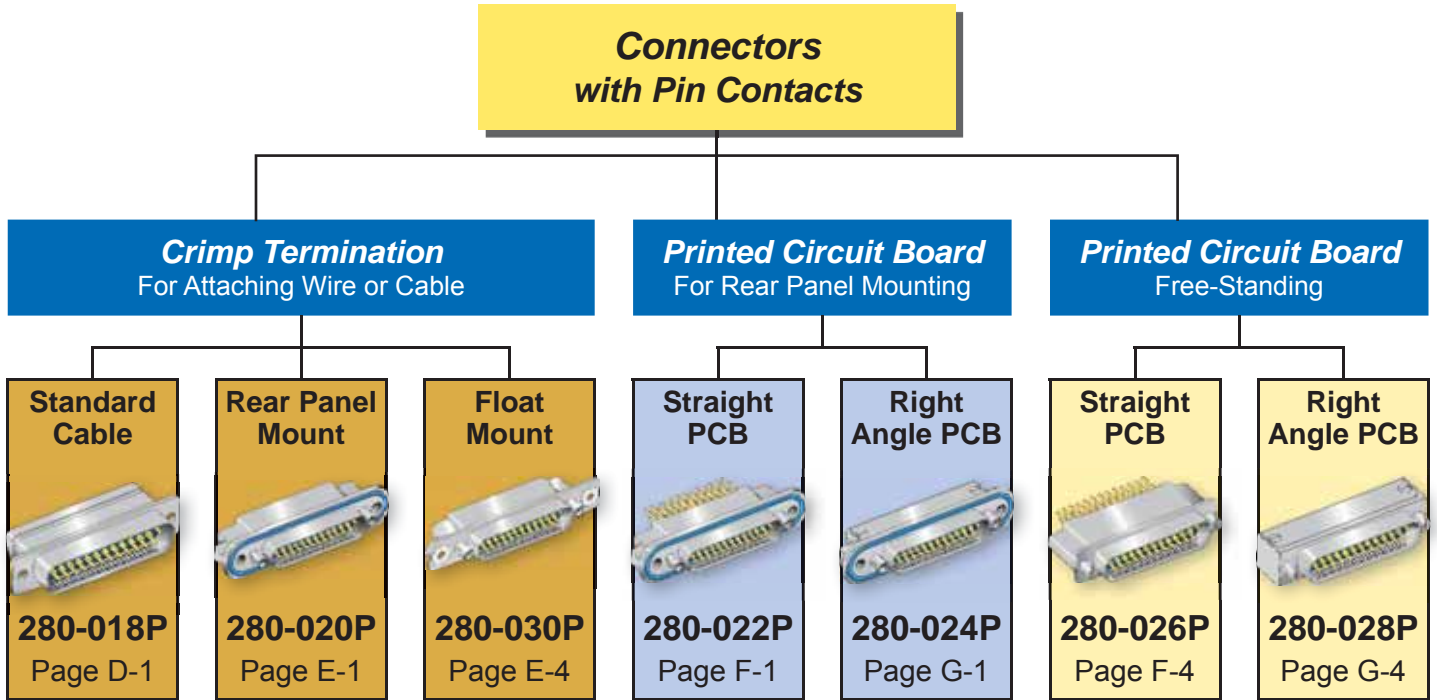

Dimensions in inches (millimeters) and are subject to change without notice.



**SERIES 28**

# HiPer-D

INSERT ARRANGEMENTS • SPECIFICATIONS • MOD CODES

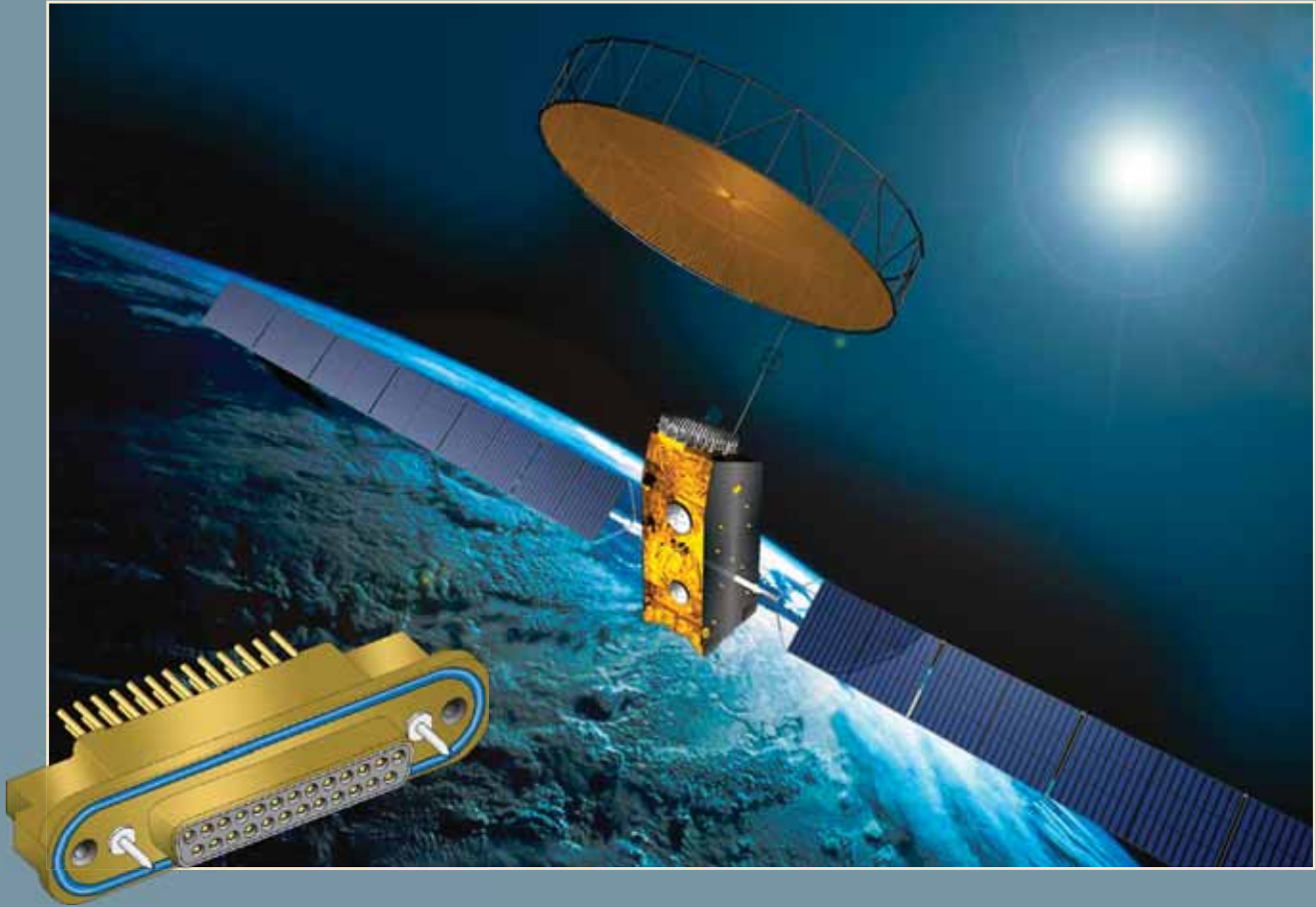

**M**IL-DTL-24308 D-Subminiature connectors are a popular choice for space flight. Their small size and reduced weight has led to their widespread use on space vehicles. The Glenair Series 28 HiPer-D connector brings the benefits of a crimp, rear-release contact system and superior performing machined shells, improved EMI shielding and robust resistance to vibration and shock to the standard D-Subminiature family. Specifying a Series 28 HiPer-D connector for space flight may include NASA screening and outgassing processing (managed with simple mod codes) or material and plating selections such as the gold-plated HiPer-D connector shown above. See page B-2 for the complete range of material and plating options.



# Series 28 HiPer-D General information and Reference Contact Arrangements, Product Specifications



## HIPER-D CONTACT ARRANGEMENTS: STANDARD DENSITY, #20 CONTACTS

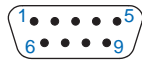

**1S9**  
9 #20 Contacts

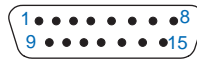

**2S15**  
15 #20 Contacts

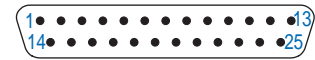

**3S25**  
25 #20 Contacts

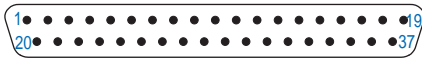

**4S37**  
37 #20 Contacts

**Mating face of pin connector.**

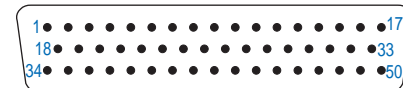

**5S50**  
50 #20 Contacts

## HIPER-D CONTACT ARRANGEMENTS: HIGH DENSITY, #22D CONTACTS

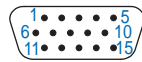

**1H15**  
15 #22D Contacts

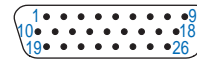

**2H26**  
26 #22D Contacts

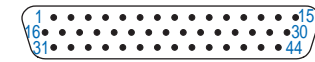

**3H44**  
44 #22D Contacts

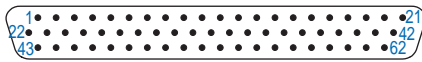

**4H62**  
62 #22D Contacts

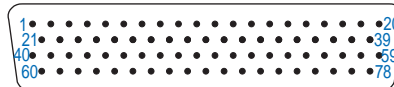

**5H78**  
78 #22D Contacts

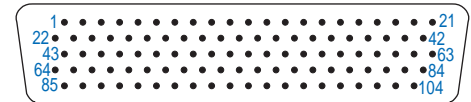

**6H104**  
104 #22D Contacts

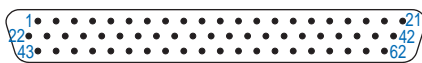

**4H62**  
62 #22D Contacts

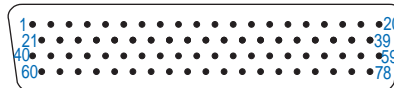

**5H78**  
78 #22D Contacts



**6H104**  
104 #22D Contacts

### SPECIFICATIONS

Current Rating	#22D 5 AMPS, #20 7.5 AMPS
Test Voltage	1000 VAC RMS
Insulation Resistance	5000 megohms minimum
Operating Temperature	-65° C. to +200° C.
Ingress Protection	IP 67
Shock	300 g.
Vibration, Random	43.92 g.

### MATERIALS AND FINISHES

Shell	Aluminum alloy
Contacts	Copper alloy, 50 microinches gold plated, stainless steel hood
Insulators	Thermoset epoxy
Retention Clips	Beryllium copper alloy
Grommet, interfacial Seal	Fluorosilicone rubber
Hardware	300 series stainless steel

Dimensions in inches (millimeters) and are subject to change without notice.



## Series 28 HiPer-D General information and Reference Shell Material and Finish Options

### About Series 28 HiPer-D Shell Material and Finish Options



HiPer-D connector shells are made of aluminum alloy and are coated to improve corrosion resistance. The United States Department of Defense (DOD) has mandated the elimination of cadmium from DOD weapons systems because of toxicity concerns. The European Union has also restricted the use of cadmium on electronics equipment (RoHS).

Glenair's **1000 Hour Grey™** nickel-PTFE plating (Code **MT**) meets the need for a high-performance cadmium replacement with excellent corrosion resistance, durability and excellent conductivity. In this catalog you will find four standard shell coatings: electroless nickel, yellow chromate over cadmium, nickel-PTFE and black zinc-nickel. The tables below show additional options that are also available on any Series 28 HiPer-D connector.

#### HIPER-D ALUMINUM SHELL PLATING CODES

Shell Plating	Plating Code	Salt Fog (Hours)	Cadmium Free	Hexavalent Chromium Free	Conductivity	Typical Applications
<b>Electroless Nickel</b>	<b>ME</b>	96	Yes	Yes	Excellent	Space vehicles, missiles, avionics, unmanned vehicles, instrumentation.
<b>Nickel-PTFE</b>	<b>MT</b>	500	Yes	Yes	Excellent	Harsh environment, soldier systems, communications equipment. Corresponds to MIL-DTL-24308 Code T.
<b>Zinc-Nickel with Black Chromate</b>	<b>ZR</b>	500	Yes	Yes	Good	Harsh environment, soldier systems. Corresponds to MIL-DTL-24308 Code K.
<b>Cadmium, Olive-Drab</b>	<b>NF</b>	500	No	No	Excellent	Harsh environment, military equipment.
<b>Cadmium with Yellow Chromate</b>	<b>JF</b>	500	No	No	Excellent	General purpose military equipment. Comparable to MIL-DTL-24308 Code F.
<b>Black Anodize</b>	<b>C</b>	336	Yes	Yes	Non-Conductive	Applications where EMI shielding is not required.
<b>Gold</b>	<b>Z2</b>	48	Yes	Yes	Excellent	Space
<b>Chem Film</b>	<b>E</b>	48	Yes	No	Excellent	Avionics

#### HIPER-D STAINLESS STEEL SHELL PLATING CODES

Shell Plating	Plating Code	Salt Fog (Hours)	Cadmium Free	Hexavalent Chromium Free	Conductivity	Typical Applications
<b>Electroless Nickel</b>	<b>ZM</b>	500	Yes	Yes	Excellent	Extreme environments where stainless steel is preferred for strength, corrosion resistance.
<b>Passivated</b>	<b>Z1</b>	500	Yes	Yes	Good	Extreme environments where stainless steel is preferred for strength, corrosion resistance.

Dimensions in inches (millimeters) and are subject to change without notice.



**Series 28 HiPer-D  
General information and Reference  
Product Specifications**



DESCRIPTION	REQUIREMENT	PROCEDURE
<b>ELECTRICAL</b>		
Contact resistance	SAE AS39029 Table V <b>Max Wire Size</b> <b>Test Current</b> <b>Voltage Drop</b> 20                      7.5                      55 22                      5                          73 24                      3                          45 26                      2                          52 28                      1.5                      54	EIA-364-06 IEC 60512-2-1 Test current in amperes. Voltage drop in milli-volts. Silver-coated copper wire, +25°C.
Low Level Contact Resistance	<b>Wire Size</b> <b>Max. Milliohms</b> 20                                      9 22                                      15 24                                      20 26                                      31 28                                      50	EIA-364-23 100 milliamperes maximum and 20 milli-volts maximum open circuit voltage
Insulation Resistance	5000 meg-ohms minimum	EIA-364-21 IEC-60512-3-1 500 volts DC ± 50 volts. Test between adjacent contacts and contacts to shell.
Dielectric withstanding voltage	No breakdown or flashover	EIA-364-20 IEC-60512-4-1 Sea level AC RMS 50 or 60 Hz. One minute dwell. 1000 volts
Current carrying capacity	<b>Contact Size</b> <b>Max Current</b> 20                                      7.5 22                                      5	EIA-364-70 Method 1 IEC-60512-5 Test 9b
Shell-to-shell resistance (connectors with ground springs)	2.5 milli-volt drop maximum	EIA-364-83 IEC-60512-2-6 Electroless nickel plated connectors.
Shielding Effectiveness	<b>Frequency GHz</b> <b>Min Attenuation (dB)</b> 0.1                                      100 0.4                                      90 0.8                                      85 1.0                                      80 3.0                                      55 6.0                                      40 10.0                                      30	EIA-364-66 IEC-60512-23-3 Pin Connector with Optional Grounding Spring, Electroless nickel plated shells
<b>MECHANICAL</b>		
Water Immersion	No evidence of water penetration into mated connectors. No evidence of water penetration into an unmated panel mounted PCB receptacle. ≥ 100 MΩ insulation resistance.	MIL-STD-810F Method 512.4 1 meter immersion 1 hour

Dimensions in inches (millimeters) and are subject to change without notice.



## Series 28 HiPer-D

### General information and Reference Product Specifications

DESCRIPTION	REQUIREMENT	PROCEDURE
Air Pressure	No detectable moisture. $\geq 100 \text{ M}\Omega$ insulation resistance.	IEC-60512-7 Test 14b 0.4 bar overpressure 48 hours immersion at a depth of 150mm in 25° C tap water.
Ingress Protection	IP67 rating	IEC-60529
Vibration, Sine	No discontinuity of greater than 1 microseconds, no cracking, breaking or loosening of parts, plug shall not become disengaged from receptacle. Connectors shall meet electrical requirements after vibration test.	EIA-364-28 Test Condition IV IEC-60512-6-4 100 milliamp test current 254 mm/sec from 10-50 Hz; 1.5 mm double amplitude from 50-140 Hz, and 60 G from 140-2,000 Hz
Vibration, Random	No discontinuity of greater than 1 microseconds, no cracking, breaking or loosening of parts, plug shall not become disengaged from receptacle. Connectors shall meet electrical requirements after vibration test.	EIA-364-28 Test Condition VI Letter J IEC-60512-6-4 100 milliamp test current 50- 2,000 Hz 43.92 g. RMS
Mechanical Shock	No discontinuity of greater than 1 microsecond, no cracking, breaking or loosening of parts, plug shall not become disengaged from receptacle. Connectors shall meet electrical requirements after shock test.	EIA-364-27 Condition D IEC-60512-6-3 3 shocks X 3 axes X 2 directions = 18 shocks 2941 m/s <sup>2</sup> (300 g's), 3 ms, half-sine
Thermal Shock	No mechanical damage or loosening of parts. Following thermal shock, connector shall meet contact resistance, DWV, Insulation resistance and shell-to-shell resistance requirements.	EIA-364-32 Test Condition IV IEC-60512-11-4 5 cycles consisting of -65° C 30 minutes, +25° C 5 minutes max., + 200° C 30 minutes, +25° C 5 minutes max.
Humidity, Cyclic (Damp Heat, Cyclic) (Moisture Resistance)	No deterioration which will adversely affect the connector. 100 meg-ohms minimum insulation resistance during the final cycle. Following the recovery period, connectors shall meet contact resistance, shell-to-shell resistance and DWV requirements.	EIA-364-31 Condition B Method III IEC-60512-11-12 80-98% RH 10 cycles (10 days) +25° C to +65° C Step 7b vibration deleted. 24 hour recovery period.
21 Day Humidity (Damp heat, Long Term)	No deterioration which will adversely affect the connector. Following the drying period, connectors shall meet 100 meg-ohms minimum, contact resistance, shell-to-shell resistance, DWV, mating and un-mating requirements.	EIA-364-31 Condition C Method II IEC-60512-11-3 Severity C 90-95% RH 40° C Apply 100 volts DC during test. 4 hours drying time at ambient temperature prior to final measurements.
Mechanical Durability, at Ambient Temperature	No deterioration which will adversely affect the connector after 2000 cycles of mating and un-mating. Connectors shall meet contact resistance, insulation resistance, shell-to-shell resistance, DWV, and mating and un-mating force.	EIA-364-09 IEC-60512-5 Test 9a

Dimensions in inches (millimeters) and are subject to change without notice.

**Series 28 HiPer-D  
General information and Reference  
Product Specifications**



DESCRIPTION	REQUIREMENT	PROCEDURE																					
Corrosion (Salt Mist)	No exposure of base metal. Connectors shall meet DWV and contact resistance requirements following the test.	EIA-364-26 IEC 60512-11-6 5% salt solution 35° C Unmated connectors Code M: Electroless nickel 48 hours Code MT: Nickel-PTFE 500 hours Code JF: Cadmium 500 Hours																					
Solderability, PC Tail Contacts	95% solder coverage. Smooth, bright and even finish.	EIA-364-52 Category 3 IEC-60512-12-1 IEC-68-2-20 Test Ta, method 1 8 hours steam aging prior to test 245° C 4-5 sec. dwell 10X magnification																					
Resistance To Soldering Heat	No damage to connector. Connectors shall meet insulation resistance and waterproof sealing requirements.	EIA-364-56 IEC-60512-12-5 Test 12e 260° C, 10 seconds (PC tail)																					
Impact, Cable Connectors	No impairment of function. Connector shall meet contact resistance, insulation resistance and waterproof sealing.	EIA-364-42 IEC-60512-5 test 7b 1 meter, 8 drops																					
Fluid Immersion	No damage from immersion in various fuels and oils. Connector shall meet mating/un-mating force and dielectric withstanding voltage.	EIA-364-10																					
Altitude Immersion	No evidence of moisture on connector interface or contacts. Connector shall meet dielectric withstanding voltage.	EIA-364-03																					
Contact Retention	<table border="1"> <thead> <tr> <th>Contact Size</th> <th>Min. Pounds</th> <th>Min. Newtons</th> </tr> </thead> <tbody> <tr> <td>22</td> <td>9</td> <td>40</td> </tr> <tr> <td>20</td> <td>9</td> <td>40</td> </tr> </tbody> </table>	Contact Size	Min. Pounds	Min. Newtons	22	9	40	20	9	40	EIA-364-29 .012 inch maximum displacement, both axial directions												
Contact Size	Min. Pounds	Min. Newtons																					
22	9	40																					
20	9	40																					
Contact Separation Force	<table border="1"> <thead> <tr> <th>Contact Size</th> <th>Min. Ounces</th> <th>Min. Newtons</th> </tr> </thead> <tbody> <tr> <td>22</td> <td>0.5</td> <td>0.14</td> </tr> <tr> <td>20</td> <td>0.7</td> <td>0.19</td> </tr> </tbody> </table>	Contact Size	Min. Ounces	Min. Newtons	22	0.5	0.14	20	0.7	0.19	SAE AS39029												
Contact Size	Min. Ounces	Min. Newtons																					
22	0.5	0.14																					
20	0.7	0.19																					
Mating and Un-mating Force	<table border="1"> <thead> <tr> <th>Shell Size</th> <th>Min. Unmating</th> <th>Max. Mating</th> </tr> </thead> <tbody> <tr> <td>1</td> <td>0.75</td> <td>10.0</td> </tr> <tr> <td>2</td> <td>1.00</td> <td>17.0</td> </tr> <tr> <td>3</td> <td>1.75</td> <td>28.0</td> </tr> <tr> <td>4</td> <td>2.50</td> <td>39.0</td> </tr> <tr> <td>5</td> <td>3.25</td> <td>49.0</td> </tr> <tr> <td>6</td> <td>4.50</td> <td>65.0</td> </tr> </tbody> </table>	Shell Size	Min. Unmating	Max. Mating	1	0.75	10.0	2	1.00	17.0	3	1.75	28.0	4	2.50	39.0	5	3.25	49.0	6	4.50	65.0	EIA-364-13 Full complement of contacts 1 to 10 inches per minute travel rate
Shell Size	Min. Unmating	Max. Mating																					
1	0.75	10.0																					
2	1.00	17.0																					
3	1.75	28.0																					
4	2.50	39.0																					
5	3.25	49.0																					
6	4.50	65.0																					
Residual Magnetism	2 μ maximum.	EIA-364-54																					
Insert Retention	No dislocation of inserts from their original positions when subjected to an axial load of 60 pounds per square inch	EIA-364-35 Apply force at a rate of 10 pounds per square inch per second until specified pressure is reached.																					

Dimensions in inches (millimeters) and are subject to change without notice.



## Series 28 HiPer-D Connectors for Space Flight

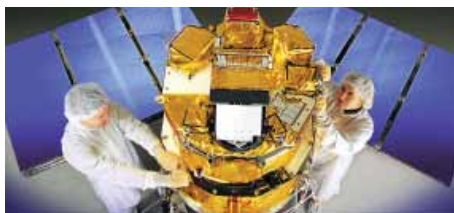

HiPer-D connectors feature space-grade materials, finishes and performance. The one-piece aluminum shell provides low residual magnetism. The rear grommet eliminates the need to backpot wires. High strength stainless steel locking hardware replaces gold-plated M24308-type brass hardware. The EMI spring provides shielding protection. The resilient interfacial seal protects mated connectors from dust, moisture and corrosion.

### HOW TO ORDER SPACE GRADE HIPER-D CONNECTORS

#### Step 1: Find a Standard Part Number

Space-grade HiPer-D connectors are available with electroless nickel (code ME) or with optional gold plated connector shells (code Z2). Other shell platings are not recommended for space applications. NASA prohibits the use of cadmium in space applications.

#### Step 2: Select a NASA Screening Level

The term "Screening Level" refers to the final inspection procedure.

Level 1 for mission-critical highest reliability

Level 2 for high reliability

Level 3 for standard reliability

#### Step 3: Choose Outgassing Processing

Standard HiPer-D connectors do not meet NASA outgassing requirements unless the connectors are specially processed. Testing has shown an oven bakeout for 8 hours at +400°F is sufficient to meet NASA requirements; however, a more expensive thermal vacuum outgassing process is also available. To specify outgassing processing, select the desired modification code from the table below.

#### Step 4: Select the Mod 429 Code that Matches the Desired Level of Screening and Outgassing

Use the following table to choose the right modification code. Add the mod code to the connector part number. Example: 280-018P4S37MEGP-**429C**

### NASA SCREENING LEVELS AND MODIFICATION CODES

NASA Screening Level	Special Screening Only		Special Screening Plus Outgassing Processing	
	Grommet and Face Seal installed	Grommet and Face Seal Deleted	8 Hour Oven Bake 400° F.	Thermal Vacuum Outgassing 24 hrs. 125° C.
Level 1 Highest Reliability	Mod 429B <sup>(1)</sup>	Mod 429F <sup>(1)</sup>	Mod 429J	Mod 429C
Level 2 High Reliability	Mod 429 <sup>(1)</sup>	Mod 429D <sup>(1)</sup>	Mod 429K	Mod 429A
Level 3 Standard Reliability	(Use standard part number)	Mod 432 <sup>(1)</sup>	Mod 186	Mod 186M

EEE-INST-002 requires outgassing for M24308.

<sup>(1)</sup> Indicates no outgassing performed

### NASA screening

NASA specification EEE-INST-002 provides instructions on selecting, screening and qualifying parts for use on NASA GSFC space flight projects. Table 2B in the NASA specification contains inspection instructions for MIL-DTL-24308 D-type connectors. Table 2B applies by similarity to HiPer-D connectors, except for residual magnetism screening. This table calls for 100% residual magnetism screening, but the HiPer-D connector will not be 100% screened unless special arrangements are made. EEE-INST-002 requires outgassing for M24308.

<sup>(1)</sup> Indicates no outgassing performed

### NASA screening levels

NASA defines three levels of screening: level 1 for highest reliability, level 2 for high reliability, and level 3 for standard reliability. Level 3 equates to standard lot acceptance inspection. Levels 1 and 2 call for additional testing.

### Qualification requirements

Projects using connectors covered by military specifications are typically able to waive qualification testing. The Series 28 HiPer-D connector is not covered by a military specification. Projects considering using this connector for space flight should obtain guidance from the overseeing space agency regarding the suitability of this connector and any testing that might be recommended.

### ASTM E595

The space industry has adopted a standardized test procedure, *ASTM E 595*, to evaluate out-gassing properties of polymers. Small samples of material are heated to 125° C. at a vacuum of 5 X 10<sup>-5</sup> torr for 24 hours. Then the sample is weighed to calculate the **Total Mass Loss (TML)**. The TML cannot exceed 1.00% of the total initial mass. The quantity of outgassed matter is calculated to determine the **Collected Volatile Condensable Material**

Dimensions in inches (millimeters) and are subject to change without notice.

## Series 28 HiPer-D Connectors for Space Flight

(CVCM). The CVCM cannot exceed 0.10% of the original specimen mass.

### Materials Approved for Space

Metal materials such as aluminum alloy connector shells, copper retention clips, gold-plated pin and socket contacts, stainless steel contact hoods and so on, are approved for space. Rigid non-metallic materials, such as LCP or epoxy insulators, and epoxy potting compounds are also approved for space flight. Resilient non-metallic materials, such as fluorosilicone grommets and interfacial seals, typically require outgassing processing, as do all adhesives.

### Residual Magnetism

Standard aluminum shell HiPer-D connectors are nonmagnetic. Spacecraft designers generally avoid the use of ferromagnetic materials, which can become magnetized and can interfere with sensitive instruments. Although D type connectors typically are 100% screened for residual magnetism, the aluminum shell HiPer-D connector has adopted the magnetic permeability requirements for space-grade MIL-DTL-83513 and MIL-DTL-38999 connectors. These specifications require 2 $\mu$  maximum magnetic permeability. This requirement is considered to be a qualification test and is not invoked as a screening test unless specifically requested.

### Cryogenic Exposure

Series 28 HiPer-D connectors are rated to -65° C. Glenair does not yet have data to validate these connectors for cryogenic applications. EEE-INST-002 states "...experience has proven it is possible for (non-certified) connector types to be used successfully at cryogenic temperatures. It is recommended that connector samples should be subjected to five cycles of cryogenic temperature...(followed by examination for cracks and DWV)".

### TML and CVML

Glenair has conducted testing on all connector materials to establish typical percentage material loss (TML) and collected volatile material loss (CVML). Please consult factory for test reports.

Dimensions in inches (millimeters) and are subject to change without notice.

### Outgassing

Plastic and rubber materials give off gaseous molecules. For example, the smell inside a new car is caused by polymer outgassing. Heat and vacuum increase the rate of diffusion. In a spacecraft the gases coming off polymers can contaminate optical surfaces and instruments. The result is degraded performance.

Glenair recommends that HiPer-D connectors for space flight should be oven baked or thermal vacuum outgassed. The table below shows HiPer-D connector materials that must be postcured or baked to meet outgassing limits. Components such as insulators and seals are routinely postcured prior to connector assembly. However, some materials such as RTV can only be outgassed once the connector is assembled. NASA states "A bakeout for outgassing control is driven by the application and may be required where tight contamination control must be maintained." This processing can be performed by Glenair; however, some customers prefer to fabricate higher level subassemblies before outgassing processing is performed.

#### OUTGASSING PROPERTIES OF HIPER-D MATERIALS

Component	Material	Outgassing Property
Insulator, PCB Trays	Thermoset epoxy	Meets ASTM E595
Grommet and Face Seal	Fluorosilicone	Postcure is required
Adhesive	Eccobond 104 A/B	Meets ASTM E595
Sealant	DC3145 and DC3140 RTV	Postcure is required
Epoxy ink	Markem 7224	Meets ASTM E595
O-ring	Fluorosilicone	Postcure is required

#### NASA EEE-INST-002 SCREENING REQUIREMENTS

Inspection/ Test	NASA Level 1	NASA Level 2
Visual inspection	100%	100%
Mechanical	2 pcs.	2 pcs.
Voltage (DWV)	2 pcs.	2 pcs.
Insulation Resistance	2 pcs.	2 pcs.
Mating and Unmating Force	2 pcs.	N/A
Contact Engagement and Separation Force	2 pcs.	N/A
Solderability/Resistance to Soldering Heat	2 pcs.	N/A

1. NASA screening requirements from Table 2B of EEE-INST-002 Screening Requirements.

#### OUTGASSING AT-A-GLANCE

- Fluorosilicone rubber components used in HiPer-D connectors, such as o-rings, grommets and seals do not comply with NASA outgassing requirements.
- NASA nevertheless recommends additional processing to reduce outgassing of all materials to minimal levels.
- An inexpensive oven bakeout delivers excellent results compared to thermal vacuum outgassing. The high temperature of the oven bakeout effectively removes volatile materials.
- Glenair 429 mod codes provide easy ordering, whichever outgassing option is required.

**SERIES 28**

# HiPer-D

CONTACTS • ASSEMBLY TOOLS • BAND-MASTER™ ATS



Series 28 HiPer-D connectors are supplied with loose crimp contacts, terminated to wires using mil spec crimp tools. The HiPer-D connector features crimp, rear-release standard size #20 and #22 gold-plated copper alloy contacts that meet the requirements of SAE AS39029. Military Specification MIL-DTL-22520 provides the aerospace/defense industry with a common set of rugged, reliable hand crimp tools. This specification controls the voltage drop and tensile strength of crimp terminations. The Series 28 HiPer-D family of products is well-supported with a complete range of contacts, tools and assembly instructions for turnkey assembly and use.





Series 28 HiPer-D  
Contacts and Tools  
Selection Guide and General information



#20 Contacts  
Page C-2



#22D Contacts  
Page C-3



Grommet Sealing Plugs  
Page C-4



Insertion/Extraction Tools  
Page C-4



Contact Crimping Tools  
Page C-4



Positioners for Crimp Tools  
Page C-4



Band-Master™ ATS Shield  
Band installation Tool  
Page C-5



Band-Master™ ATS Shield  
Bands  
Page C-5

Pin  
Contact

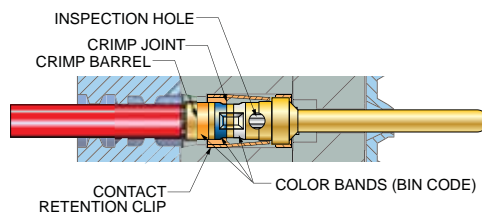

Socket  
Contact

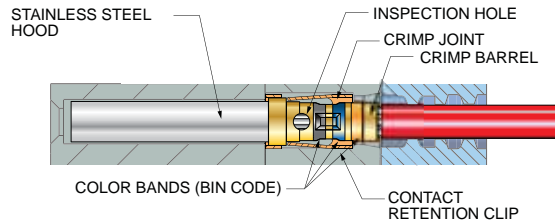

## About HiPer-D Contacts

This section of the catalog contains ordering information for contacts, crimp tools and insertion/extraction tools. HiPer-D connectors are supplied with loose crimp contacts. Contacts are terminated to wire using crimp tools and are snapped into place by hand or with a hand-held insertion tool. Damaged or miswired contacts may be removed from the connector using extraction tools.

Although the connectors are supplied with a full complement of contacts, extra contacts are frequently purchased as spares or to use for quality assurance purposes such as crimp tensile tests.

HiPer-D contacts conform to the requirements of *Aerospace Standard AS39029*. This SAE specification defines the design, dimensions and performance of contacts used in aerospace grade electrical connectors. The "general specification" covers a variety of contacts. The "slash sheets" contain dimensions and other information for specific types of contacts. Each contact is assigned a *Basic Identification Number (BIN)*, a three digit code corresponding to the color code on the contacts. A *Qualified Products List (QPL)* identifies those manufacturers whose products have been verified to meet all requirements.

## About Crimp Tools

Series 28 contacts are crimped to wire using mil spec crimpers. *Military Specification MIL-DTL-22520* provides the aerospace/defense industry with a common set of rugged, reliable hand crimp tools. This specification controls the voltage drop and tensile strength of crimp terminations.

*Before ordering, check to see if you might already have these tools!* We have listed the military part number and the Daniels part number. Daniels Manufacturing Corporation is the leading manufacturer of mil spec crimp tools. Glenair stocks all these tools for immediate delivery.

Dimensions in inches (millimeters) and are subject to change without notice.



# Series 28 HiPer-D Contacts and Tools

## #20 Crimp Contacts for Standard Density Contact Arrangements

### Size #20 Crimp Contacts



Pin Contact



Socket Contact

Standard size #20 contacts accept #20 to #24 AWG wire. These gold-plated copper alloy contacts meet the requirements of SAE AS39029.

**1** Pin contact. Fits HiPer-D pin connectors and M24308/4 connectors with standard density contact arrangements.

**2** Socket contact. Fits HiPer-D socket connectors and M24308/2 connectors with standard density contact arrangements.

Contact Type	Fig.	Wire Size	Part Number	M39029 Part Number
Pin	1	#20-24	<a href="#">850-022-20-369</a>	<a href="#">M39029/64-369</a>
Socket	2	#20-24	<a href="#">850-021-20-368</a>	<a href="#">M39029/63-368</a>

### Material and Finish

Copper alloy, 50 microinches gold plated per ASTM B488 Type II Code C Class 1,27 over nickel plate per QQ-N-290 Class 2, 50-150 microinches.

Socket contact hood: 305 CRES, passivated.

### Specifications

**Current Rating:** 7.5 Amps maximum

**Voltage Drop** (at 7.5 Amps and 25° C, #20AWG silver-plated wire):  
55 millivolts maximum

**Temperature Range:** -65° to + 200° C.

**Socket Contact Minimum Separation Force**  
0.7 ounces

See SAE AS39029 for additional electrical, mechanical and environmental specifications.

### Crimp Tools and Insertion/ Removal Tools

Crimper: 809-015 (M22520/2-01)

Positioner: 859-016 (M22520/2-08)

Insertion/Removal Tool: 859-017  
(M81969/39-01)

### CRIMP TENSILE STRENGTH

Axial load in minimum pounds.

Wire Gauge	Silver or Tin Coated Copper Wire	Nickel Coated Copper Wire
#20	20	19
#22	12	8
#24	8	6

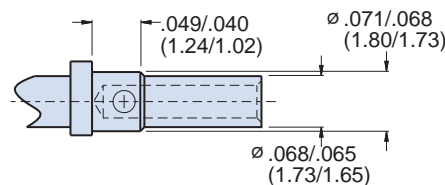
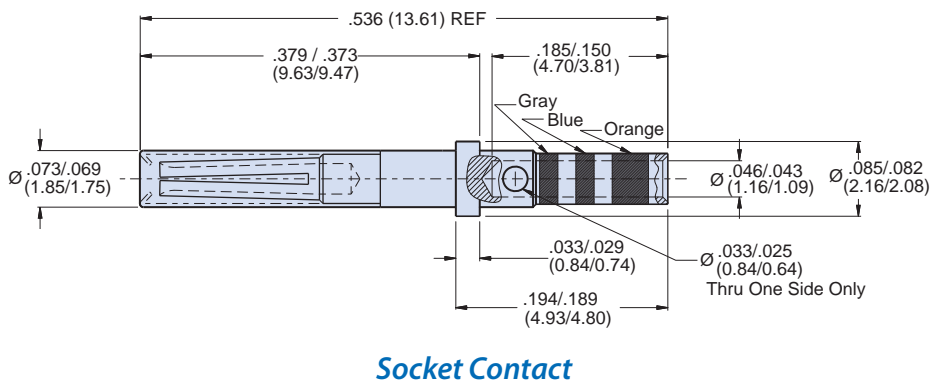
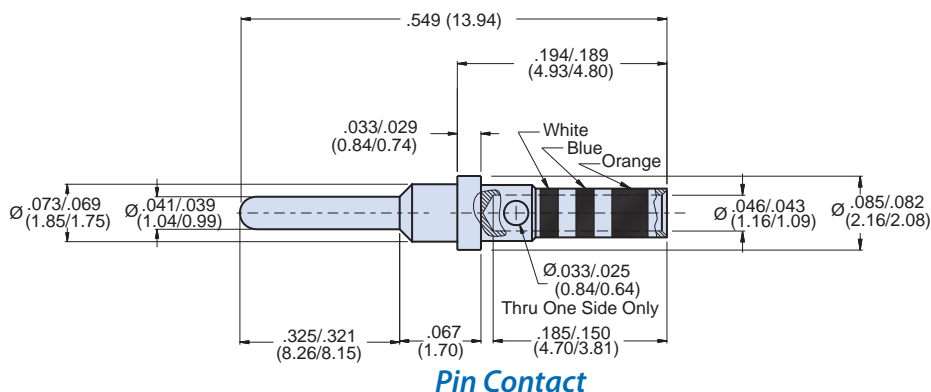

Dimensions in inches (millimeters) and are subject to change without notice.

# Series 28 HiPer-D Contacts and Tools

## #22D Crimp Contacts for High Density Contact Arrangements



### Size #22D Crimp Contacts



Pin Contact



Socket Contact

Size #22D contacts accept #22 to #28 AWG wire. These gold-plated copper alloy contacts meet the requirements of SAE AS39029.

**1** Pin contact. Fits HiPer-D pin connectors and M24308/4 connectors with high density contact arrangements.

**2** Socket contact. Fits HiPer-D socket connectors and M24308/2 connectors with high density contact arrangements.

Contact Type	Fig.	Wire Size	Part Number	M39029 Part Number
Pin	1	#22-28	850-002-22-360	M39029/58-360
Socket	2	#22-28	850-003-22-354	M39029/57-354

### Material and Finish

Copper alloy, 50 microinches gold plated per ASTM B488 Type II Code C Class 1,27 over nickel plate per QQ-N-290 Class 2, 50-150 microinches.

Socket contact hood: 305 CRES, passivated.

### Specifications

**Current Rating:** 5 Amps maximum

**Contact Resistance** (at 5 Amps and 25° C, #22 AWG silver-plated wire):  
73 millivolt drop maximum

**Temperature Range:** -65° to +200° C.

**Socket Contact Minimum Separation Force**  
0.7 ounces

See SAE AS39029 for additional electrical, mechanical and environmental specifications.

### CRIMP TENSILE STRENGTH

Axial load in minimum pounds.

Wire Gage	Silver or Tin Coated Copper Wire	Nickel Coated Copper Wire
#22	12	8
#24	8	6
#26	5	3
#28	3	2

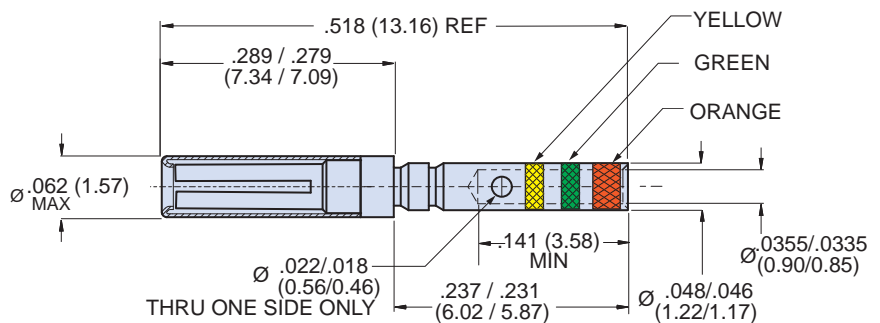
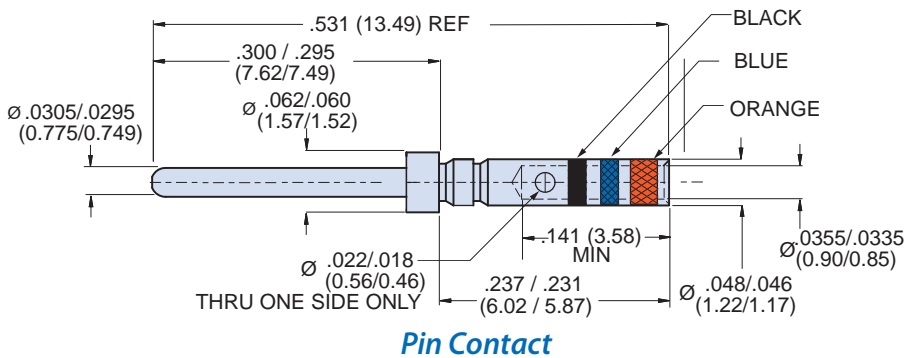

### CRIMP TOOLS AND INSERTION/EXTRACTION TOOL

Contact Type	Part Number	Crimp Tool	Positioner	Insertion/Extraction Tool
Pin	850-002-22-360	809-015	859-018	859-020
Socket	850-003-22-354	809-015	859-019	859-020

Dimensions in inches (millimeters) and are subject to change without notice.



### Miniature Adjustable Crimp Tool and Positioners



These crimp tools perform precision eight indent crimps for gas-tight wire terminations and excellent tensile strength. Adjustment wheel has 8 settings. Ratchet mechanism prevents improper crimps. Use with bayonet-type positioners, ordered separately. Check calibration with M22520/3 gages. Length is 6.75 inches, weight is approx. 10 oz.

**A** Standard M22520/2-01 crimper. Use with size #22D and #20 HiPer-D contacts. Requires positioner, ordered separately.

**B** Positioner for use with standard #20 contacts. Use with contacts 850-022-20-369 (M39029/64-369) and 850-021-20-368 (M39029/63-368).

**C** Positioner for use with #22D pin contacts. Use with contact 850-002-22-360 (M39029/58-360).

**D** Positioner for use with #22D socket contacts. Use with contact 850-003-22-354 (M39029/57-354).

Figure	Part Number	Military Part Number	Daniels Part Number <sup>(1)</sup>
A	<b>809-015</b>	M22520/2-01	AFM8
B	<b>859-016</b>	M22520/2-08	K13-1
C	<b>859-018</b>	M22520/2-09	K42
D	<b>859-019</b>	M22520/2-06	K41

(1) Daniels Manufacturing Corporation, Orlando, Florida is the industry-leading supplier of mil spec contact termination tooling. In addition to the tools shown in this catalog, the Daniels product line includes a complete range of installation tools and semi-automatic equipment.

### Contact Insertion and Removal Tools

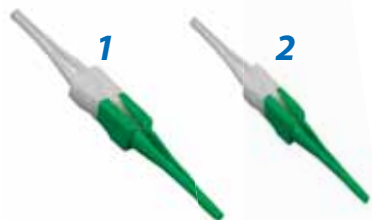

**1** Insertion/Extraction Tool for #20HD contacts. This plastic tool features green insertion tip and white extraction tip.

**2** Insertion/Extraction Tool for #22D contacts. This plastic tool features green insertion tip and white extraction tip.

Figure	Size	Type	Part Number	Military Part Number	Daniels Part Number
1	#20HD	Insertion/Extraction	<b>859-017</b>	M81969/39-01	M81969/39-01
2	#22D	Insertion/Extraction	<b>859-020</b>	M81969/14-01	M81969/14-01

### Grommet Sealing Plugs

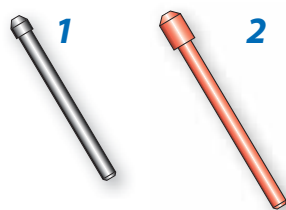

Grommet sealing plugs are used to seal unwired contact cavities. These plugs conform to MS27488 requirements. After installing unwired contacts into unused cavities, insert knob end of sealing plug into grommet until it bottoms against the unwired contact per illustration. Install sealing plugs with standard contact insertion/extraction tools.

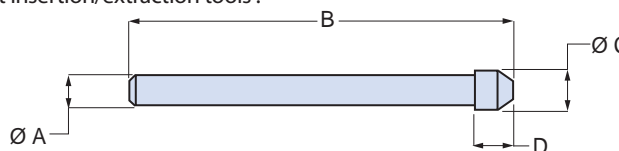

Fig.	Size	Color	Part Number	Military Part Number	Insertion/Removal Tool	A Ref.		B Ref.		C Ref.		D Ref.	
						in.	mm	in.	mm	in.	mm	in.	mm
1	#22	Black	<b>859-021</b>	MS27488-22-2	M81969/14-01	.042	1.07	.51	13.0	.062	1.57	.125	3.18
2	#20	Red	<b>859-012</b>	MS27488-20-2	M81969/39-01	.053	1.35	.82	20.8	.085	2.16	.125	3.18

Here's  
a Tip!



#### Installation of Sealing Plugs

"When installing sealing plug in connector cavities without contacts, the end opposite the knob shall be inserted first and the knob shall be seated against the grommet face. When installing into cavities with contacts, the sealing plugs shall be installed knob end first and shall bottom on the contact wire barrel."

(NAVAIR 01-1A-505-1 installation manual)

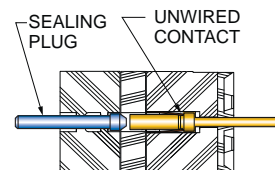

Dimensions in inches (millimeters) and are subject to change without notice.

CAGE Code 06324

Printed in U.S.A.

## Glenair Band-Master™ Advanced Termination System (ATS): How To Order



Fast, cost-effective shield termination. Attach cable shields to backshells with **Band-Master™ ATS** stainless steel straps. The **Band-Master™ ATS** system offers fast termination and the flexibility to handle a wide range of parts with just one band size. Approved for aerospace and defense, these straps have successfully passed rigorous shock, vibration and environmental testing.

**1** Band installation Tool. Use with .240" (6.10 mm) wide bands. 6.75 inches (172 mm) length, 1.2 pounds (0.6 Kg.)

**2** Standard Band, .240" (6.10 mm) wide. Available in two lengths, flat or pre-coiled. Stainless steel.

Figure	Description	Part Number
1	Band installation Tool	600-058

Figure	Length		Part Number		Accommodates Diameter	
	in.	mm	Flat	Pre-Coiled	in.	mm
2	14.250	362.1	600-052	600-052-1	1.8	45.7
2	18.000	457.2	600-090	600-090-1	2.5	63.5

Contact Glenair or visit our website (glenair.com) to view our complete line of **Band-Master™ ATS** products, including pneumatic tools for high volume production and calibration kits.

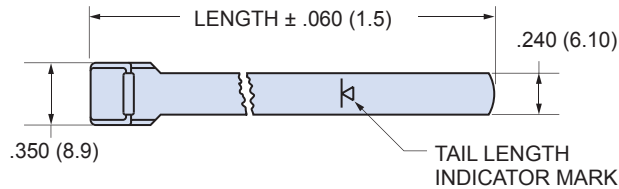

## Band-Master™ ATS Shield Termination instructions

1. Prepare Cable Braid for termination process (Figure 1).
2. Push Braid forward over Adapter Retention Lip to the Adapter incline Point (or .4" [10.2mm] minimum braid length). Milk Braid as required to remove slack and insure a snug fit around the shield termination area (Figure 2).
3. Prepare the Band in the following manner:
 

IMPORTANT: Due to Connector/Adapter circumference, it may be necessary to prepare the Band around the Cable or Retention Area.

  - A. Roll Band through the Buckle Slot twice. (Bands must be double-coiled.)
  - B. Pull on Band until Mark (▶) is within approximately .250 inch (6.4mm) of Buckle Slot (Figure 3). The Band may be tightened further if desired.

**NOTE:** Prepared Band should have (▶) Mark visible approximately where shown in Figure 3.

### Shield Termination Clamping Process (Figures 4 thru 8)

**NOTE:** To free Tool Handles, move Holding Clips to center of Tool.

4. Squeeze Gripper Release Lever and insert Band into the front end opening of the Tool. (NOTE: Circular portion of looped band must always face downward.)
5. Aligning the Band and Tool with the Shield Termination Area, squeeze Black Pull-Up Handle repeatedly using short strokes until it locks against Tool Body. (This indicates the Band is compressed to the Tool Pre-calibrated Tension.)
6. Complete the Clamping Process by squeezing the Gray Cut-Off Handle.
7. Remove excess band from tool and dispose.
8. inspect Shield Termination.

**NOTE:** If alignment of band and shield is unsatisfactory, tension on band can be relaxed by pushing on slotted release lever on top of tool. Make adjustments as necessary and again squeeze black pull-up handle.

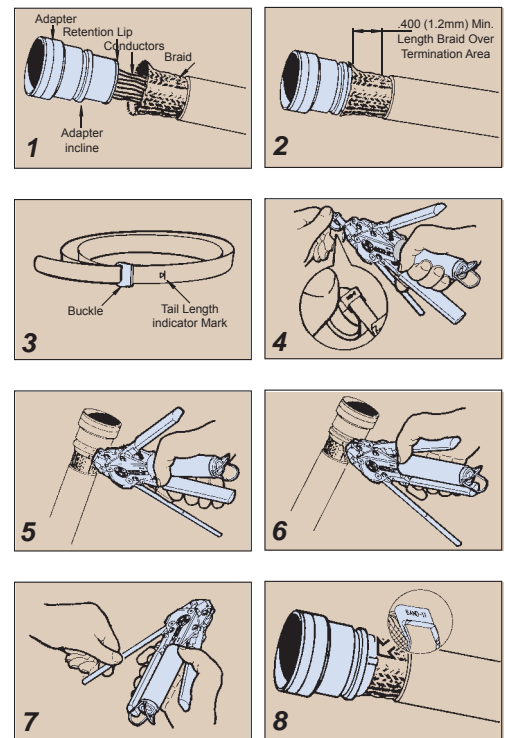

Dimensions in inches (millimeters) and are subject to change without notice.

**SERIES 28**

# HiPer-D

## SECTIONS D, E, F AND G CONNECTOR SELECTION GUIDE

### Connectors with Pin Contacts

#### Crimp Termination For Attaching Wire or Cable

Standard  
Cable



**280-018P**  
Page D-1

Rear Panel  
Mount



**280-020P**  
Page E-1

Float  
Mount



**280-030P**  
Page E-4

#### Printed Circuit Board For Rear Panel Mounting

Straight  
PCB



**280-022P**  
Page F-1

Right  
Angle PCB



**280-024P**  
Page G-1

#### Printed Circuit Board Free-Standing

Straight  
PCB



**280-026P**  
Page F-4

Right  
Angle PCB



**280-028P**  
Page G-4

### Connectors with Socket Contacts

#### Crimp Termination For Attaching Wire or Cable

Standard  
Cable



**280-019S**  
Page D-3

Rear Panel  
Mount



**280-021S**  
Page E-7

Float  
Mount



**280-031S**  
Page E-10

#### Printed Circuit Board For Rear Panel Mounting

Straight  
PCB



**280-023S**  
Page F-11

Right  
Angle PCB

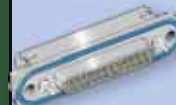

**280-025S**  
Page G-11

#### Printed Circuit Board Free-Standing

Straight  
PCB



**280-027S**  
Page F-14

Right  
Angle PCB



**280-029S**  
Page G-14



# 280-018P Series 28 HiPer-D Pin Connectors for Cable Termination



## HiPer-D Pin Connectors with Crimp Contacts

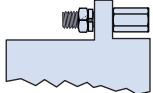
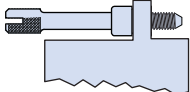
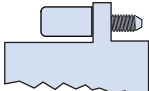
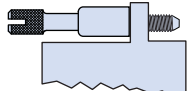

HiPer-D pin connectors feature crimp, rear-releaseable size #20 or #22D contacts. Interchangeable with standard M24308-type D-Subminiature connectors, the HiPer-D features a rugged machined aluminum shell, waterproof sealing and optional ground springs for improved resistance to electromagnetic interference. Gold-plated size #20 contacts conform to M39029/64-369 and accept #20 to #24 AWG wire. Gold-plated size #22D contacts conform to M39029/58-360 and accept #22 to #28 AWG wire. Contacts are packaged with connector. Terminate contacts with crimp tools purchased separately. Glass-reinforced thermoset epoxy insulators, copper alloy retention clips. Fluorosilicone face seal and rear grommet meet IP67 immersion requirement. 1000 VAC, 5 Amps (#22D) or 7.5 Amps (#20).

HOW TO ORDER							
Sample Part Number							
280-018P	1S9	ME	G	S			
Part Number	Shell Size - Insert Arr.	Shell Material/Finish	EMI Spring	Hardware Option			
<b>280-018P</b> HiPer-D Cable Connector With Pin Contacts	Standard Density #20 Contacts	<b>ME</b> Aluminum with Electroless Nickel Finish <i>general purpose applications, excellent conductivity</i>	<b>G</b> EMI Spring  <b>N</b> No Spring	 <b>N</b> Thru-Hole No Hardware	 <b>P</b> Female Jackpost		
	Layout					Contact Quantity	
	<b>1S9</b> 9 <b>2S15</b> 15 <b>3S25</b> 25 <b>4S37</b> 37 <b>5S50</b> 50						
	High Density #22D Contacts	<b>MT</b> Aluminum with Nickel-PTFE Finish <i>1000 Hour Grey™ maximum corrosion protection, durability, and excellent conductivity (non-reflective grey)</i>	<b>L</b> Low-Profile Captivated Jackscrew, Hex Head	 <b>K</b> Slot-Head Extended Jackscrew			
	Layout				Contact Quantity		
	<b>1H15</b> 15 <b>2H26</b> 26 <b>3H44</b> 44 <b>4H62</b> 62 <b>5H78</b> 78 <b>6H104</b> 104						
					<b>JF</b> Aluminum with Cadmium, Yellow Chromate <i>for severe environments, excellent conductivity</i>	 <b>S</b> Low-Profile Captivated Jackpost, Hex Head	 <b>T</b> Slot-Head Extended Captivated Jackpost

SPECIFICATIONS	
Current Rating	#22D 5 AMPS, #20 7.5 AMPS
Test Voltage	1000 VAC RMS
Insulation Resistance	5000 megohms minimum
Operating Temperature	-65° C. to +200° C.
Ingress Protection	IP 67
Shock	300 g.
Vibration, Random	43.92 g.

MATERIALS AND FINISHES	
Shell	Aluminum alloy
Contacts	Copper alloy, 50 microinches gold plated
Insulators	Thermoset epoxy
Retention Clips	Beryllium copper alloy
Grommet and Seal	Fluorosilicone rubber
Hardware	300 series stainless steel

Dimensions in inches (millimeters) and are subject to change without notice.



# 280-018P Series 28 HiPer-D Pin Connectors for Cable Termination

## HIPER-D CONTACT ARRANGEMENTS: STANDARD DENSITY, #20 CONTACTS

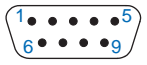

**1S9**  
9 #20 Contacts

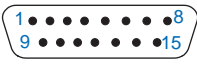

**2S15**  
15 #20 Contacts

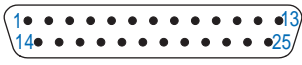

**3S25**  
25 #20 Contacts

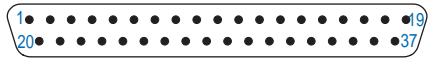

**4S37**  
37 #20 Contacts

**Mating face of pin connector.**



**5S50**  
50 #20 Contacts

## HIPER-D CONTACT ARRANGEMENTS: HIGH DENSITY, #22D CONTACTS

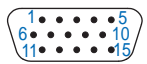

**1H15**  
15 #22D Contacts

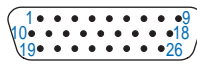

**2H26**  
26 #22D Contacts

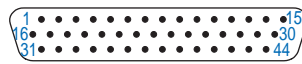

**3H44**  
44 #22D Contacts

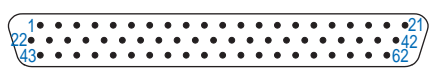

**4H62**  
62 #22D Contacts

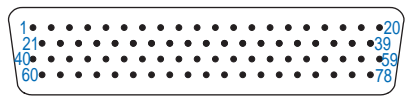

**5H78**  
78 #22D Contacts

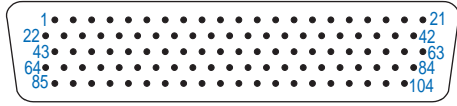

**6H104**  
104 #22D Contacts

**Mating face of pin connector.**

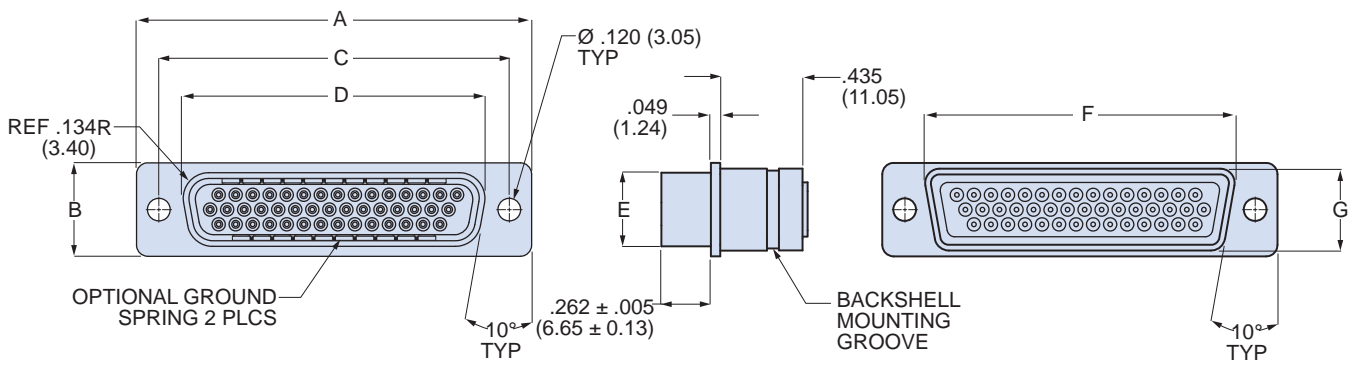

280-018P DIMENSIONS														
Shell Size	A		B		C Basic		D		E		F Max.		G Max.	
	in	mm	in	mm	in.	mm	in	mm	in	mm	in.	mm	in.	mm
<b>1</b>	1.213	30.81	.494	12.55	.984	24.99	.726	18.44	.389	9.88	.769	19.53	.432	10.97
<b>2</b>	1.541	39.14	.494	12.55	1.312	33.32	1.054	26.77	.389	9.88	1.093	27.76	.432	10.97
<b>3</b>	2.088	53.04	.494	12.55	1.852	47.04	1.594	40.49	.389	9.88	1.635	41.53	.432	10.97
<b>4</b>	2.729	69.32	.494	12.55	2.500	63.50	2.242	56.95	.389	9.88	2.282	57.96	.432	10.97
<b>5</b>	2.635	66.93	.605	15.37	2.406	61.11	2.139	54.33	.501	12.73	2.188	55.58	.544	13.82
<b>6</b>	2.729	69.32	.668	16.97	2.500	63.50	2.272	57.71	.563	14.30	2.312	58.72	.606	15.39

Dimensions in inches (millimeters) and are subject to change without notice.

**280-019S**  
**Series 28 HiPer-D Socket Connectors**  
**for Cable Termination**



**HiPer-D Socket Connectors with Crimp Contacts**



HiPer-D socket connectors feature crimp, rear-releaseable size #20 or #22D contacts. Intermateable with standard M24308-type D-Subminiature connectors, the HiPer-D features a rugged machined aluminum shell and waterproof sealing. Gold-plated size #20 contacts conform to M39029/63-368 and accept #20 to #24 AWG wire. Gold-plated size #22D contacts conform to M39029/57-354 and accept #22 to #28 AWG wire. Contacts are packaged with connector. Terminate contacts with crimp tools purchased separately. Glass-reinforced thermoset epoxy insulators, copper alloy retention clips. Fluorosilicone rear grommet meets IP67 immersion requirement. Shell has backshell attachment groove. 1000 VAC, 5 Amps (#22D) or 7.5 Amps (#20).

HOW TO ORDER			
Sample Part Number			
280-019S	2H26	MT	N
<b>Part Number</b>	<b>Shell Size - Insert Arr.</b>	<b>Shell Material/Finish</b>	<b>Hardware Option</b>
<b>280-019S</b> HiPer-D Cable Connector With Socket Contacts	Standard Density #20 Contacts  Layout <b>Contact Quantity</b> <b>1S9</b> 9 <b>2S15</b> 15 <b>3S25</b> 25 <b>4S37</b> 37 <b>5S50</b> 50  High Density #22D Contacts  Layout <b>Contact Quantity</b> <b>1H15</b> 15 <b>2H26</b> 26 <b>3H44</b> 44 <b>4H62</b> 62 <b>5H78</b> 78 <b>6H104</b> 104	<b>ME</b> Aluminum with Electroless Nickel Finish <i>general purpose applications, excellent conductivity</i>  <b>MT</b> Aluminum with Nickel-PTFE Finish <i>1000 Hour Grey™ maximum corrosion protection, durability, and excellent conductivity (non-reflective grey)</i>  <b>JF</b> Aluminum with Cadmium, Yellow Chromate <i>for severe environments, excellent conductivity</i>	<b>N</b> Thru-Hole No Hardware  <b>L</b> Low-Profile Captivated Jackscrew, Hex Head  <b>S</b> Low-Profile Captivated Jackpost, Hex Head  <b>P</b> Female Jackpost  <b>K</b> Slot-Head Extended Jackscrew  <b>T</b> Slot-Head Extended Captivated Jackpost

SPECIFICATIONS	
Current Rating	#22D 5 AMPS, #20 7.5 AMPS
Test Voltage	1000 VAC RMS
Insulation Resistance	5000 megohms minimum
Operating Temperature	-65° C. to +200° C.
Ingress Protection	IP 67
Shock	300 g.
Vibration, Random	43.92 g.

MATERIALS AND FINISHES	
Shell	Aluminum alloy
Contacts	Copper alloy, 50 microinches gold plated
Insulators	Thermoset epoxy
Retention Clips	Beryllium copper alloy
Grommet and Seal	Fluorosilicone rubber
Hardware	300 series stainless steel

Dimensions in inches (millimeters) and are subject to change without notice.





# 280-019S Series 28 HiPer-D Socket Connectors for Cable Termination

## HIPER-D CONTACT ARRANGEMENTS: STANDARD DENSITY, #20 CONTACTS

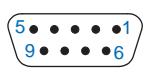

**1S9**  
9 #20 Contacts

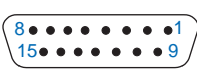

**2S15**  
15 #20 Contacts

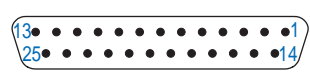

**3S25**  
25 #20 Contacts

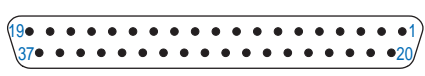

**4S37**  
37 #20 Contacts

**Mating face of  
socket connector.**

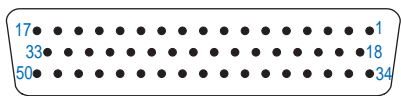

**5S50**  
50 #20 Contacts

## HIPER-D CONTACT ARRANGEMENTS: HIGH DENSITY, #22D CONTACTS



**1H15**  
15 #22D Contacts

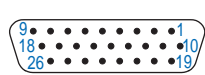

**2H26**  
26 #22D Contacts

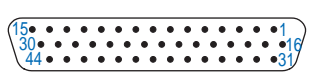

**3H44**  
44 #22D Contacts

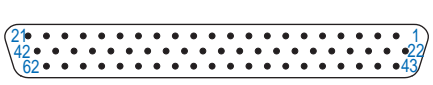

**4H62**  
62 #22D Contacts

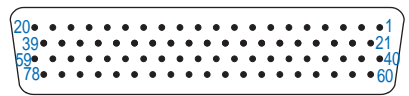

**5H78**  
78 #22D Contacts

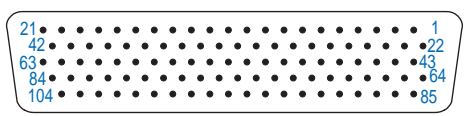

**6H104**  
104 #22D Contacts

**Mating face of socket connector.**

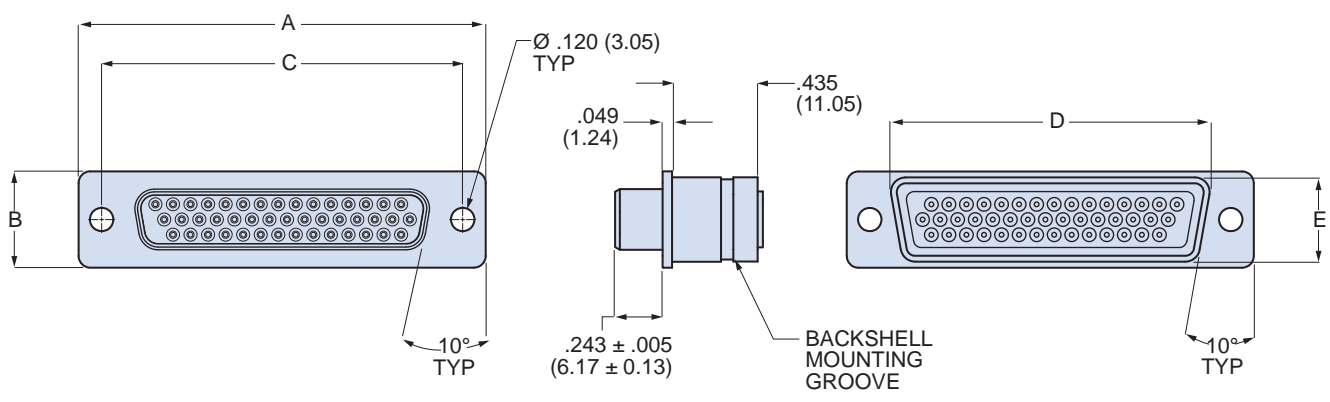

280-019S DIMENSIONS										
Shell Size	A		B		C Basic		D		E	
	in ± .015	mm ± 0.38	in ± .015	mm ± 0.38	in. in.	mm mm	in ± .005	mm ± 0.13	in ± .005	mm ± 0.13
<b>1</b>	1.213	30.81	.494	12.55	.984	24.99	.769	19.53	.432	10.97
<b>2</b>	1.541	39.14	.494	12.55	1.312	33.32	1.093	27.76	.432	10.97
<b>3</b>	2.088	53.04	.494	12.55	1.852	47.04	1.635	41.53	.432	10.97
<b>4</b>	2.729	69.32	.494	12.55	2.500	63.50	2.282	57.96	.432	10.97
<b>5</b>	2.635	66.93	.605	15.37	2.406	61.11	2.188	55.58	.544	13.82
<b>6</b>	2.729	69.32	.668	16.97	2.500	63.50	2.312	58.72	.606	15.39

Dimensions in inches (millimeters) and are subject to change without notice.

# 280-018P and 280-019S Panel Cutouts Series 28 HiPer-D



## PANEL CUTOUT FOR REAR-MOUNTED CONNECTORS 280-018P AND 280-019S

### Rear Mount Panel Cutout <sup>(1)</sup>

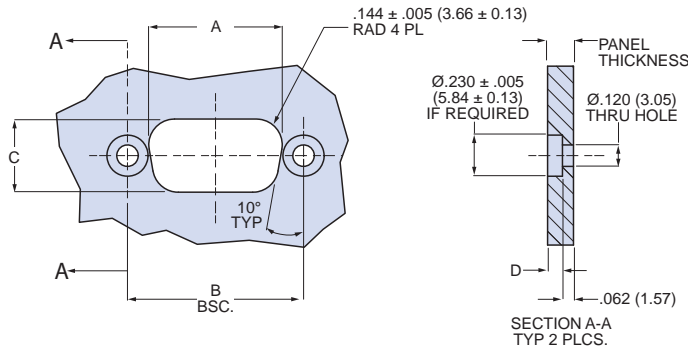

Shell Size	A		B Basic		C	
	in	mm	in	mm	in.	mm
1	.742	30.81	.984	24.99	.405	10.29
2	1.070	39.14	1.312	33.32	.405	10.29
3	1.610	53.04	1.852	47.04	.405	10.29
4	2.258	69.32	2.500	63.50	.405	10.29
5	2.155	66.93	2.406	61.11	.517	13.13
6	2.288	69.32	2.500	63.50	.579	14.71

### Application Note for Rear Panel Mounting

- (1) For rear mounting with female Jackposts, use shortened Jackposts per the table at right. For panel thickness greater than .062 (1.57), the panel must be counterbored.

Panel Thickness	D		Female Jackpost Part Number	
	in	mm		
No Panel	N/A	N/A	289-015-A	
.031	0.79	N/A	289-015-B	
.047	1.19	N/A	289-015-C	
.062	1.57	N/A	289-015-D	
.093	2.36	.031	0.79	289-015-D
.125	3.18	.063	1.60	289-015-D
.156	3.96	.094	2.39	289-015-D

## PANEL CUTOUT FOR FRONT-MOUNTED CONNECTORS 280-018P AND 280-019S

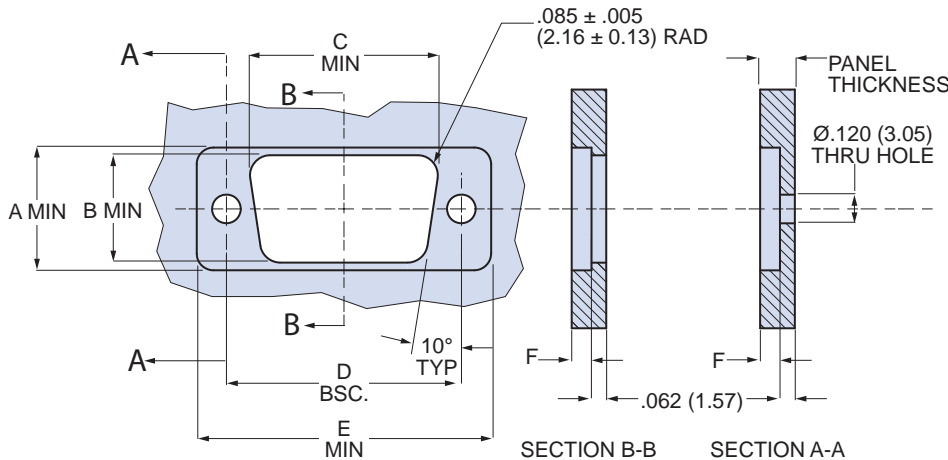

### Front Mount Panel Cutout

WHEN FRONT PANEL MOUNTING ON PANELS THICKER THAN .062 (1.57), CONNECTOR WILL SIT IN PANEL AS SHOWN

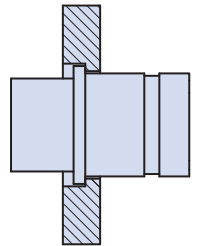

Shell Size	A		B		C		D Basic		E	
	in	mm	in	mm	in.	mm	in	mm	in.	mm
1	.514	13.06	.450	11.43	.787	19.99	.984	24.99	1.233	31.32
2	.514	13.06	.450	11.43	1.111	28.22	1.312	33.32	1.561	39.65
3	.514	13.06	.450	11.43	1.653	41.99	1.852	47.04	2.108	53.54
4	.514	13.06	.450	11.43	2.300	58.42	2.500	63.50	2.749	69.82
5	.625	15.88	.552	14.02	2.190	55.63	2.406	61.11	2.655	67.44
6	.688	17.48	.614	15.60	2.315	58.80	2.500	63.50	2.749	69.82

### Application Note for Front Panel Mounting

Panels thicker than .062 (1.57) should be machined as shown in order to prevent interference with mounting hardware and backshells. Front-mounted connectors are compatible with female Jackpost 289-015-A or M24308/26-1.

Dimensions in inches (millimeters) and are subject to change without notice.



280-020P

## Series 28 HiPer-D Rear Panel Mount Pin Connectors with Crimp Contacts

### HiPer-D Panel Mount Pin Connectors with Crimp Contacts

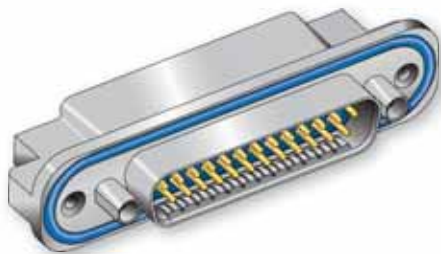

Rear panel mount HiPer-D pin connectors feature crimp, rear-releaseable size #20 or #22D contacts and flange O-ring for a watertight panel seal. Intermateable with standard M24308-type D-Subminiature connectors, the HiPer-D features a rugged machined aluminum shell, environmental sealing and optional ground springs for improved resistance to electromagnetic interference. #4-40 threaded mounting holes simplify panel attachment. Threaded holes on the rear of the connector allow attachment of HiPer-D EMI backshells. Contacts are packaged with connector. Terminate contacts with crimp tools purchased separately. Glass-reinforced thermoset epoxy insulators, copper alloy retention clips. Fluorosilicone face seal and rear grommet meet IP67 immersion requirement (mated). 1000 VAC, 5 Amps (#22D) or 7.5 Amps (#20).

#### HOW TO ORDER

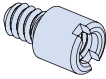
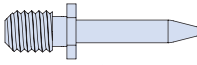
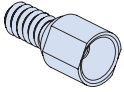
Sample Part Number						
280-020P	3H44	MT	N	P		
Part Number	Shell Size - Insert Arr.	Shell Material/Finish	EMI Spring	Hardware Option		
<b>280-020P</b> HiPer-D Panel Mount Connector With Crimp Pin Contacts	Standard Density #20 Contacts	<b>ME</b> Aluminum with Electroless Nickel Finish <i>general purpose applications, excellent conductivity</i>	<b>G</b> EMI Spring	 <b>N</b> #8-32 Threaded Hole	 <b>P</b> #4-40 Female Jackpost	
	Layout					<b>MT</b> Aluminum with Nickel-PTFE Finish <i>1000 Hour Grey™ maximum corrosion protection, durability, and excellent conductivity (non-reflective grey)</i>
	<b>1S9</b>		9			
	<b>2S15</b>		15			
	<b>3S25</b>		25	<b>JF</b> Aluminum with Cadmium, Yellow Chromate <i>for severe environments, excellent conductivity</i>	 <b>G</b> Male Guide Pin for Blind Mating	 <b>B</b> Female Guide Bushing for Blind Mating
	High Density #22D Contacts	<b>JF</b> Aluminum with Cadmium, Yellow Chromate <i>for severe environments, excellent conductivity</i>				
	Layout					
	<b>1H15</b>		15			
	<b>2H26</b>		26			
	<b>3H44</b>		44			
<b>4H62</b>	62					
<b>5H78</b>	78					
<b>6H104</b>	104					

#### SPECIFICATIONS

Current Rating	#22D 5 AMPS, #20 7.5 AMPS
Test Voltage	1000 VAC RMS
Insulation Resistance	5000 megohms minimum
Operating Temperature	-65° C. to +200° C.
Ingress Protection	IP 67
Shock	300 g.
Vibration, Random	43.92 g.

#### MATERIALS AND FINISHES

Shell	Aluminum alloy
Contacts	Copper alloy, 50 microinches gold plated
Insulators	Thermoset epoxy, glass-filled
Retention Clips	Beryllium copper alloy
Grommet and Seal	Fluorosilicone rubber
Hardware	300 series stainless steel

Dimensions in inches (millimeters) and are subject to change without notice.

© 2011 Glenair, Inc.

CAGE Code 06324

Printed in U.S.A.

GLENAIR, INC. • 1211 AIR WAY • GLENDALE, CA 91201-2497 • 818-247-6000 • FAX 818-500-9912

www.glenair.com

E-1

E-Mail: sales@glenair.com

# 280-020P

## Series 28 HiPer-D Rear Panel Mount Pin Connectors with Crimp Contacts



### HIPER-D CONTACT ARRANGEMENTS: STANDARD DENSITY, #20 CONTACTS

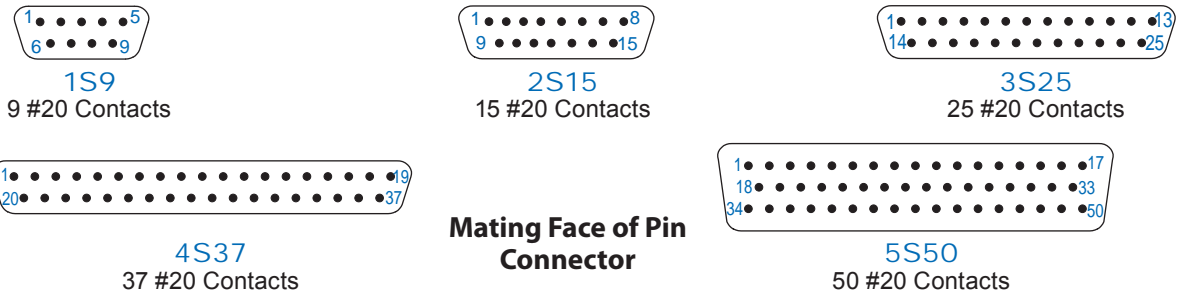

### HIPER-D CONTACT ARRANGEMENTS: HIGH DENSITY, #22D CONTACTS

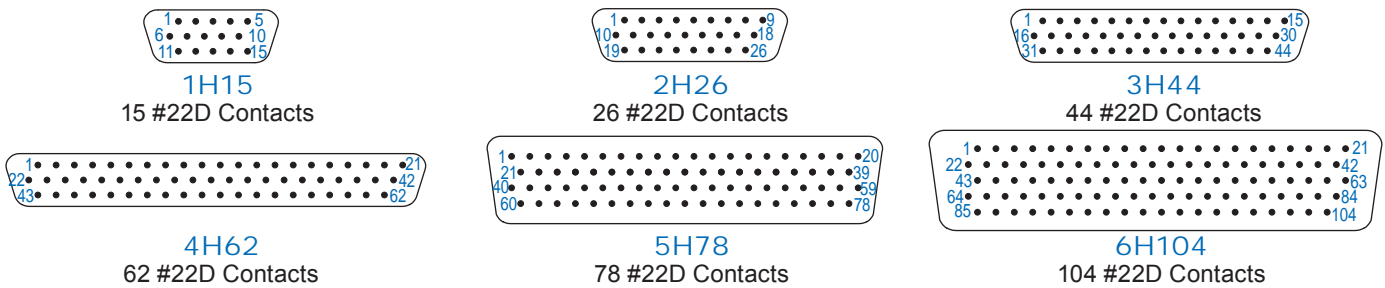

### 280-020P DIMENSIONS

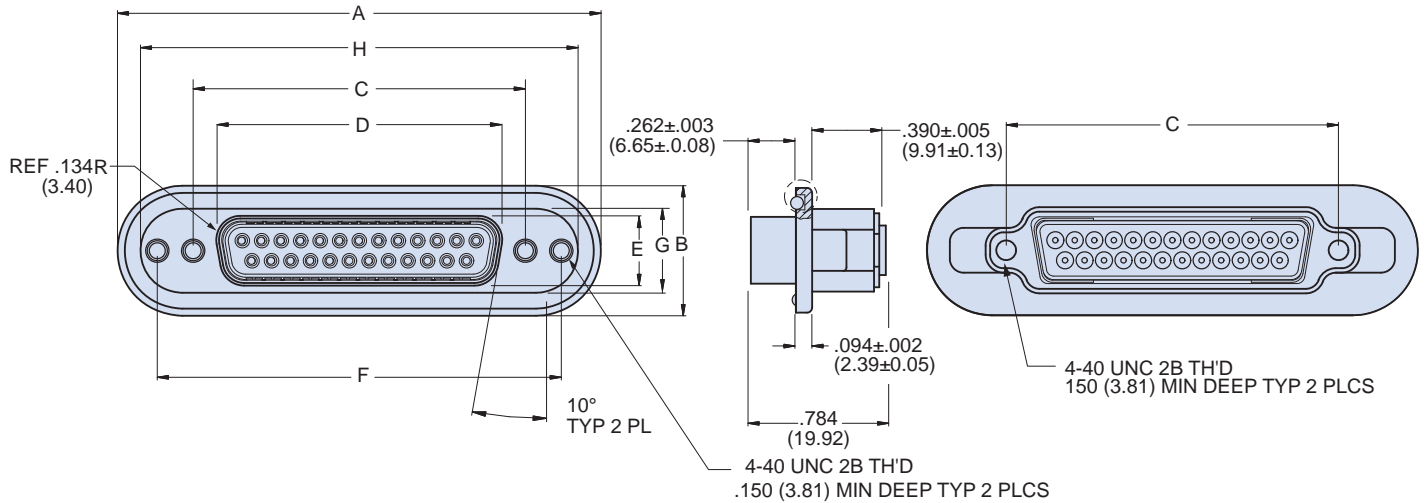

Shell Size	A		B		C Basic		D		E		F Basic		G		H	
	in	mm	in	mm	in.	mm	in	mm	in	mm	in	mm	in	mm	in	mm
1	1.865	47.37	.725	18.42	.984	24.99	.726	18.44	.389	9.88	1.424	36.17	.469	11.91	1.609	40.87
2	2.200	55.88	.725	18.42	1.312	33.32	1.054	26.77	.389	9.88	1.752	44.50	.469	11.91	1.944	49.38
3	2.736	69.49	.725	18.42	1.852	47.04	1.594	40.49	.389	9.88	2.292	58.22	.469	11.91	2.480	62.99
4	3.385	85.98	.725	18.42	2.500	63.50	2.242	56.95	.389	9.88	2.940	74.68	.469	11.91	3.129	79.48
5	3.289	83.54	.837	21.26	2.406	61.11	2.139	54.33	.501	12.73	2.846	72.29	.581	14.76	3.033	77.04
6	3.383	85.93	.899	22.83	2.500	63.50	2.272	57.71	.563	14.30	2.940	74.68	.643	16.33	3.127	79.43

Dimensions in inches (millimeters) and are subject to change without notice.





# 280-020P

## Series 28 HiPer-D Rear Panel Mount Pin Connectors with Crimp Contacts

### HARDWARE OPTION

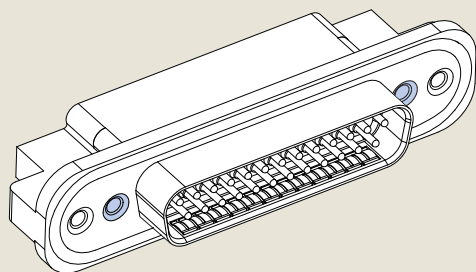

**N**  
**No Mating Hardware**

Connector is supplied without mating hardware. Hardware attachment holes are #8-32 UNC 2B, .150 min. deep.

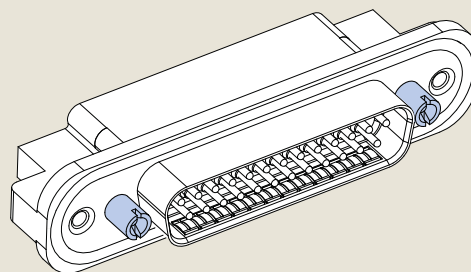

**P**  
**Jackposts**

Connector is supplied with non-removable stainless steel jackposts. #4-40 UNC 2B thread. Stainless steel.

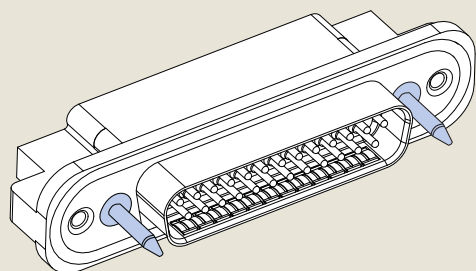

**G**  
**Guide Pins**

Connector is supplied with stainless steel non-removable guide pins. Mates with type "B" guide bushings on mating connector.

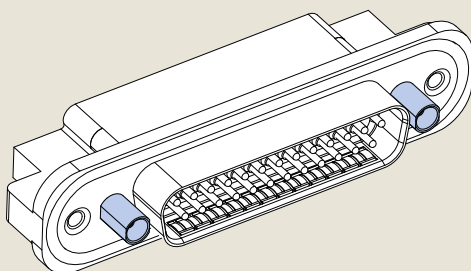

**B**  
**Female Guide Bushing**

Connector is supplied with stainless steel non-removable bushings. Mates with type "G" guide pins on mating connector.

### 280-020P PANEL CUTOUTS

REAR PANEL MOUNT CUTOUT RECOMMENDATIONS AS VIEWED FROM FRONT FACE OF PANEL

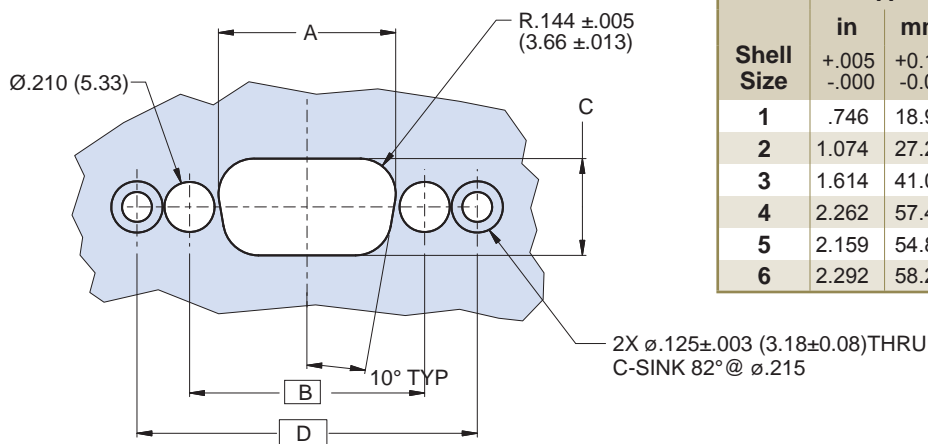

Shell Size	A		B Basic		C		D Basic	
	in	mm	in	mm	in.	mm	in	mm
1	.746	18.95	.984	24.99	.409	10.39	1.424	36.17
2	1.074	27.28	1.312	33.32	.409	10.39	1.752	44.50
3	1.614	41.00	1.852	47.04	.409	10.39	2.292	58.22
4	2.262	57.45	2.500	63.50	.409	10.39	2.940	74.68
5	2.159	54.84	2.406	61.11	.521	13.23	2.846	72.29
6	2.292	58.22	2.500	63.50	.583	14.81	2.940	74.68

Dimensions in inches (millimeters) and are subject to change without notice.

280-030P  
Series 28 HiPer-D

Float Mount Pin Connectors with Crimp Contacts



HiPer-D Float Mount Pin Connectors for Blind Mating

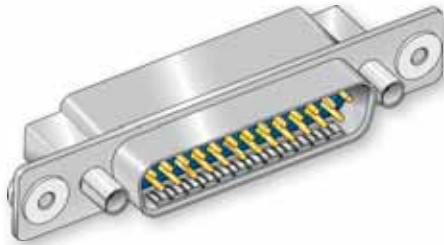

280-030P3S25MGB

280-030P HiPer-D pin connectors feature stainless steel floating bushings for rack-to-panel mounting. Attach to rack with #4-40 screws (not supplied with connector). Crimp, rear-releaseable size #20 or #22D contacts. Intermateable with standard M24308-type D-Subminiature connectors, the HiPer-D features a rugged machined aluminum shell, rubber seals and optional ground springs for improved resistance to electromagnetic interference. Threaded holes on the rear of the connector allow attachment of HiPer-D EMI backshells. Contacts are packaged with connector. Terminate contacts with crimp tools purchased separately. Glass-reinforced thermoset epoxy insulators, copper alloy retention clips. Fluorosilicone face seal and rear grommet meet IP67 immersion requirement (mated). 1000 VAC, 5 Amps (#22D) or 7.5 Amps (#20).

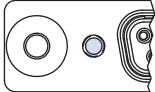
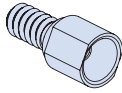
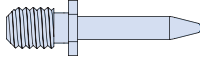
HOW TO ORDER						
Sample Part Number						
280-030P	4H62	MT	G	B		
Part Number	Shell Size - Insert Arr.	Shell Material/Finish	EMI Spring	Hardware Option		
<b>280-030P</b> HiPer-D Float Mount Connector With Crimp Pin Contacts	Standard Density #20 Contacts	<b>ME</b> Aluminum with Electroless Nickel Finish <i>general purpose applications, excellent conductivity</i>	<b>G</b> EMI Spring  <b>N</b> No Spring	 <b>N</b> #8-32 Threaded Holes		
	<b>Layout</b>				<b>MT</b> Aluminum with Nickel-PTFE Finish <i>1000 Hour Grey™ maximum corrosion protection, durability, and excellent conductivity (non-reflective grey)</i>	
	<b>Contact Quantity</b>					
	<b>1S9</b>					9
	<b>2S15</b>					15
	<b>3S25</b>	25				
	High Density #22D Contacts	<b>JF</b> Aluminum with Cadmium, Yellow Chromate <i>for severe environments, excellent conductivity</i>	 <b>B</b> Female Guide Bushings			
	<b>Layout</b>					
	<b>Contact Quantity</b>					
	<b>1H15</b>			15		
<b>2H26</b>	26					
<b>3H44</b>	44					
<b>4H62</b>	62					
<b>5H78</b>	78					
<b>6H104</b>	104	 <b>G</b> Male Guide Pins				

SPECIFICATIONS	
Current Rating	#22D 5 AMPS, #20 7.5 AMPS
Test Voltage	1000 VAC RMS
Insulation Resistance	5000 megohms minimum
Operating Temperature	-65° C. to +200° C.
Ingress Protection	IP 67
Shock	300 g.
Vibration, Random	43.92 g.

MATERIALS AND FINISHES	
Shell	Aluminum alloy
Contacts	Copper alloy, 50 microinches gold plated
Insulators	Thermoset epoxy, glass-filled
Retention Clips	Beryllium copper alloy
Grommet and Seal	Fluorosilicone rubber
Hardware	300 series stainless steel

Dimensions in inches (millimeters) and are subject to change without notice.



# 280-030P Series 28 HiPer-D Float Mount Pin Connectors with Crimp Contacts

## HIPER-D CONTACT ARRANGEMENTS: STANDARD DENSITY, #20 CONTACTS

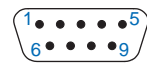

**1S9**  
9 #20 Contacts

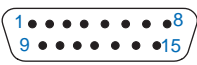

**2S15**  
15 #20 Contacts

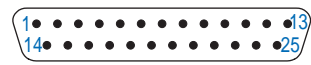

**3S25**  
25 #20 Contacts

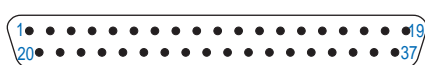

**4S37**  
37 #20 Contacts

**Mating Face of Pin Connector**

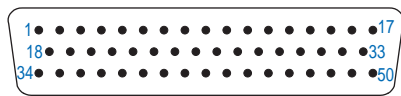

**5S50**  
50 #20 Contacts

## HIPER-D CONTACT ARRANGEMENTS: HIGH DENSITY, #22D CONTACTS



**1H15**  
15 #22D Contacts

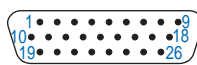

**2H26**  
26 #22D Contacts



**3H44**  
44 #22D Contacts

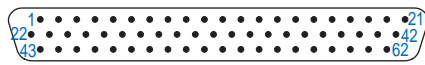

**4H62**  
62 #22D Contacts

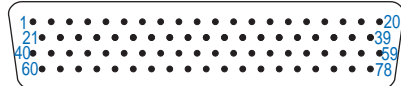

**5H78**  
78 #22D Contacts

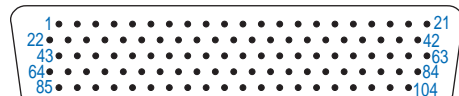

**6H104**  
104 #22D Contacts

**Mating Face of Pin Connector**

## 280-030P DIMENSIONS

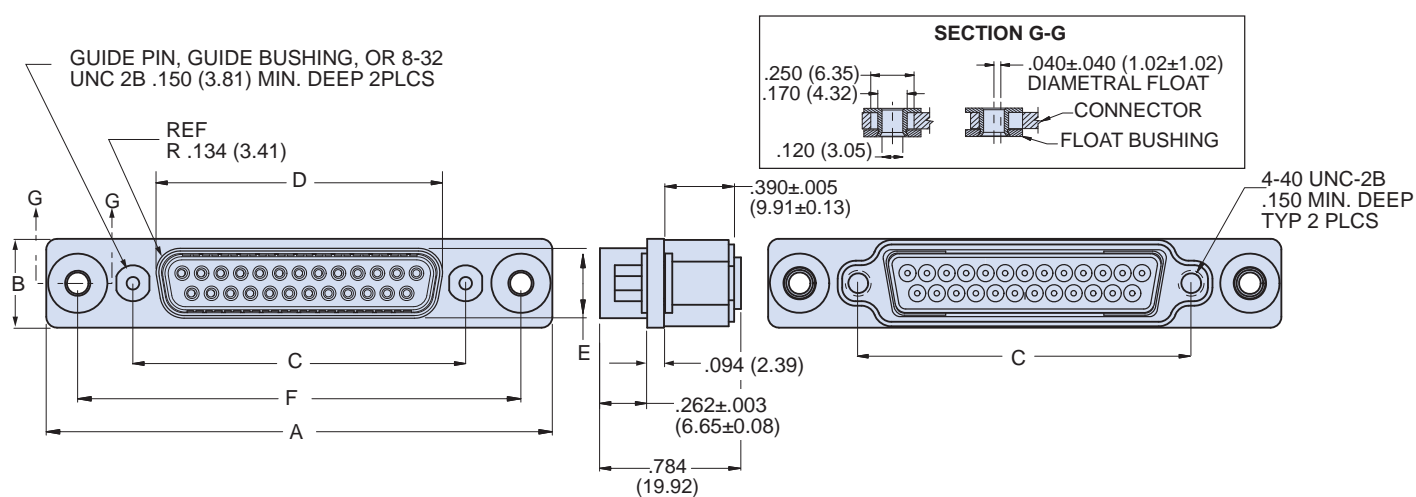

Shell Size	A		B		C Basic		D		E		F Basic	
	in	mm	in	mm	in.	mm	in	mm	in	mm	in	mm
1	1.986	50.44	.494	12.55	.984	24.99	.726	18.44	.389	9.88	1.636	41.55
2	2.314	58.78	.494	12.55	1.312	33.32	1.054	26.77	.389	9.88	1.964	49.89
3	2.854	72.49	.494	12.55	1.852	47.04	1.594	40.49	.389	9.88	2.504	63.60
4	3.502	88.95	.494	12.55	2.500	63.50	2.242	56.95	.389	9.88	3.152	80.06
5	3.408	86.56	.600	15.24	2.406	61.11	2.139	54.33	.501	12.73	3.058	77.67
6	3.502	88.95	.662	16.81	2.500	63.50	2.272	57.71	.563	14.30	3.152	80.06

Dimensions in inches (millimeters) and are subject to change without notice.

**280-030P**  
**Series 28 HiPer-D**  
**Float Mount Pin Connectors with Crimp Contacts**



**HARDWARE OPTION**

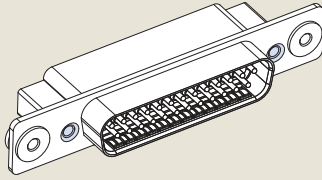

**N**

**No Mating Hardware**

Connector is supplied with threaded holes. Holes are #8-32 UNC 2B, .150 (3.81) min. deep.

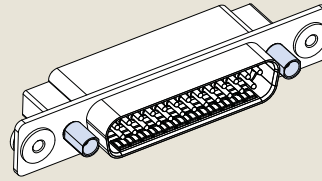

**B**

**Female Guide Bushing**

Connector is supplied with non-removable female guide bushings. Stainless steel.

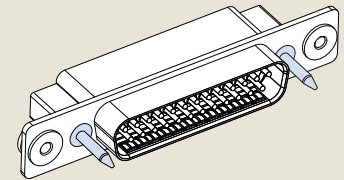

**G**

**Guide Pins**

Connector is supplied with stainless steel non-removable guide pins.

**280-030P PANEL CUTOUT**

REAR PANEL CUTOUT VIEWED FROM FRONT OF PANEL

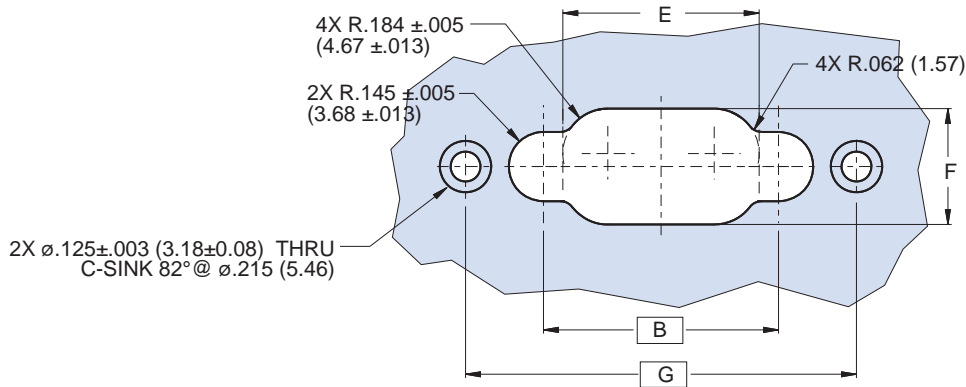

Shell Size	B Basic		E		F		G Basic	
	in	mm	in	mm	in.	mm	in	mm
1	.984	24.99	.826 +.005 -.000	20.98 +0.13 -0.00	.489 +.005 -.000	12.42 +0.13 -0.00	1.636	41.55
2	1.312	33.32	1.154	29.31	.489	12.42	1.964	49.89
3	1.852	47.04	1.694	43.03	.489	12.42	2.504	63.60
4	2.500	63.50	2.342	59.49	.489	12.42	3.152	80.06
5	2.406	61.11	2.239	56.87	.601	15.27	3.058	77.67
6	2.500	63.50	2.372	60.25	.663	16.84	3.152	80.06

Dimensions in inches (millimeters) and are subject to change without notice.

CAGE Code 06324

Printed in U.S.A.





280-021S

## Series 28 HiPer-D Panel Mount Socket Connectors with Crimp Contacts

### HiPer-D Panel Mount Socket Connectors with Crimp Contacts

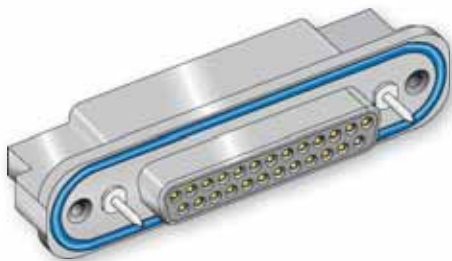

Rear panel mount HiPer-D socket connectors feature crimp, rear-releaseable size #20 or #22D contacts and a flange O-ring for a watertight panel seal. Intermateable with standard M24308-type D-Subminiature connectors, the HiPer-D features a rugged machined aluminum shell and environmental sealing. #4-40 threaded mounting holes simplify panel attachment. Threaded holes on the rear of the connector allow attachment of HiPer-D EMI backshells. Contacts are packaged with connector. Terminate contacts with crimp tools purchased separately. Glass-reinforced thermoset epoxy insulators, copper alloy retention clips. Connector meets IP67 immersion requirement (mated). 1000 VAC, 5 Amps (#22D) or 7.5 Amps (#20).

#### HOW TO ORDER

##### Sample Part Number

280-021S

3H44

ME

P

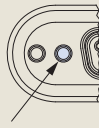
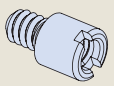
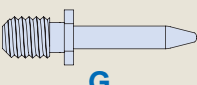
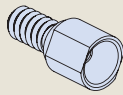
Part Number	Shell Size - Insert Arr.	Shell Material/Finish	Hardware Option	
<b>280-021S</b> HiPer-D Panel Mount Connector With Crimp Socket Contacts	Standard Density #20 Contacts	<b>ME</b> Aluminum with Electroless Nickel Finish <i>general purpose applications, excellent conductivity</i>  <b>MT</b> Aluminum with Nickel-PTFE Finish <i>1000 Hour Grey™ maximum corrosion protection, durability, and excellent conductivity (non-reflective grey)</i>  <b>JF</b> Aluminum with Cadmium, Yellow Chromate <i>for severe environments, excellent conductivity</i>	 <b>N</b> #8-32 Threaded Hole	 <b>P</b> #4-40 Female Jackpost
	Layout <b>Contact Quantity</b> <b>1S9</b> 9 <b>2S15</b> 15 <b>3S25</b> 25 <b>4S37</b> 37 <b>5S50</b> 50			
	High Density #22D Contacts		 <b>G</b> Male Guide Pin for Blind Mating	 <b>B</b> Female Guide Bushing for Blind Mating
	Layout <b>Contact Quantity</b> <b>1H15</b> 15 <b>2H26</b> 26 <b>3H44</b> 44 <b>4H62</b> 62 <b>5H78</b> 78 <b>6H104</b> 104			

#### SPECIFICATIONS

Current Rating	#22D 5 AMPS, #20 7.5 AMPS
Test Voltage	1000 VAC RMS
Insulation Resistance	5000 megohms minimum
Operating Temperature	-65° C. to +200° C.
Ingress Protection	IP 67
Shock	300 g.
Vibration, Random	43.92 g.

#### MATERIALS AND FINISHES

Shell	Aluminum alloy
Contacts	Copper alloy, 50 microinches gold plated
Insulators	Thermoset epoxy, glass-filled
Retention Clips	Beryllium copper alloy
Grommet and Seal	Fluorosilicone rubber
Hardware	300 series stainless steel

Dimensions in inches (millimeters) and are subject to change without notice.

© 2011 Glenair, Inc.

CAGE Code 06324

Printed in U.S.A.

GLENAIR, INC. • 1211 AIR WAY • GLENDALE, CA 91201-2497 • 818-247-6000 • FAX 818-500-9912

www.glenair.com

E-7

E-Mail: sales@glenair.com

# 280-021S

## Series 28 HiPer-D Panel Mount Socket Connectors with Crimp Contacts



### HIPER-D CONTACT ARRANGEMENTS: STANDARD DENSITY, #20 CONTACTS

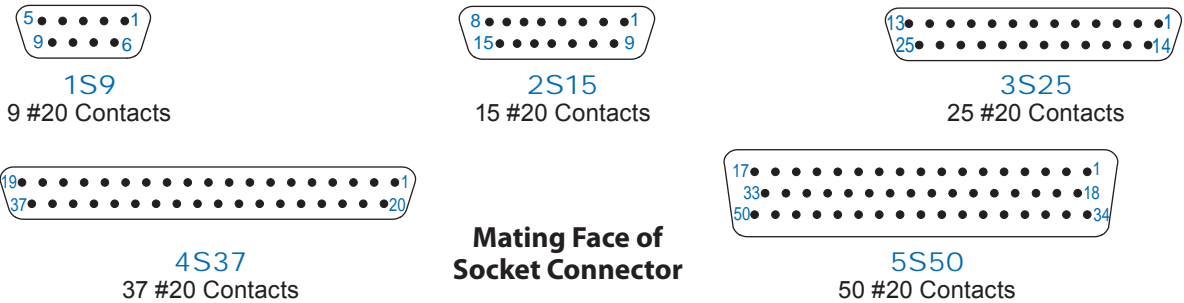

### HIPER-D CONTACT ARRANGEMENTS: HIGH DENSITY, #22D CONTACTS

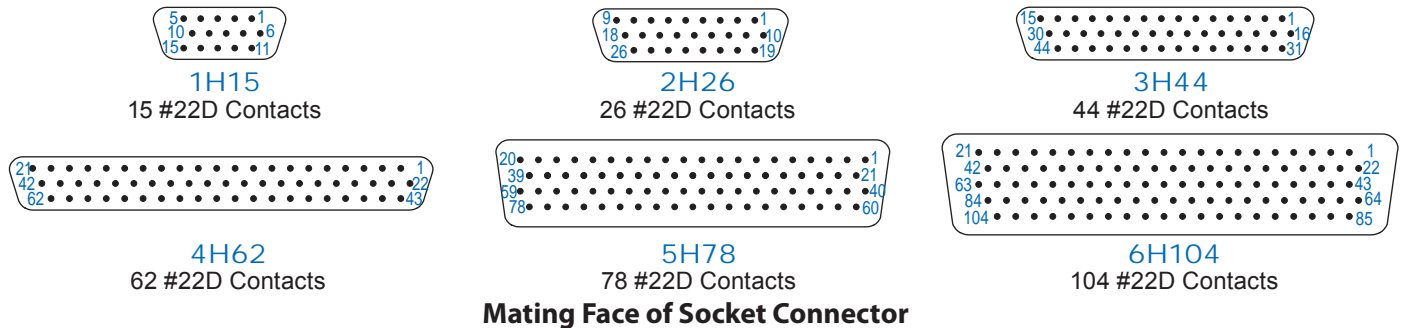

### 280-021S DIMENSIONS

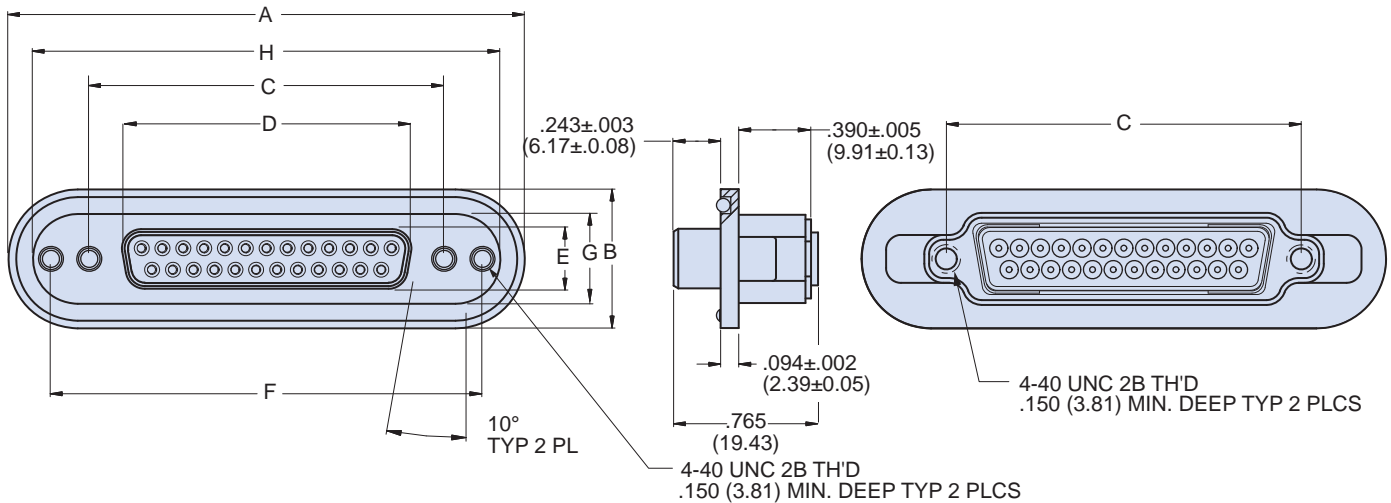

Shell Size	A		B		C Basic		D		E		F Basic		G		H	
	in	mm	in	mm	in.	mm	in	mm	in	mm	in	mm	in	mm	in	mm
1	1.865	47.37	.725	18.42	.984	24.99	.643	16.33	.311	7.90	1.424	36.17	.469	11.91	1.609	40.87
2	2.200	55.88	.725	18.42	1.312	33.32	.971	24.66	.311	7.90	1.752	44.50	.469	11.91	1.944	49.38
3	2.736	69.49	.725	18.42	1.852	47.04	1.511	38.38	.311	7.90	2.292	58.22	.469	11.91	2.480	62.99
4	3.385	85.98	.725	18.42	2.500	63.50	2.159	54.84	.311	7.90	2.940	74.68	.469	11.91	3.129	79.48
5	3.289	83.54	.837	21.26	2.406	61.11	2.064	52.43	.423	10.74	2.846	72.29	.581	14.76	3.033	77.04
6	3.383	85.93	.899	22.83	2.500	63.50	2.189	55.60	.485	12.32	2.940	74.68	.643	16.33	3.127	79.43

Dimensions in inches (millimeters) and are subject to change without notice.



280-021S

Series 28 HiPer-D Panel Mount Socket Connectors with Crimp Contacts

HARDWARE OPTION

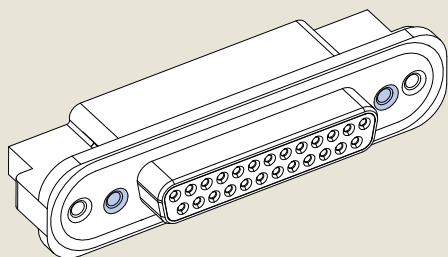

**N**

**No Mating Hardware**

Connector is supplied without mating hardware. Hardware attachment holes are #8-32 UNC 2B, .150 min. deep.

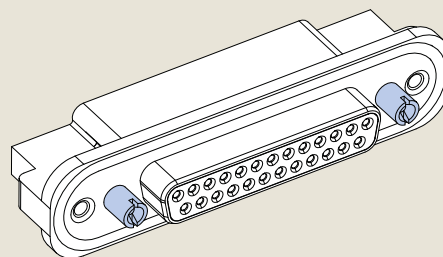

**P**

**Jackposts**

Connector is supplied with non-removable stainless steel jackposts. #4-40 UNC 2B thread. Stainless steel.

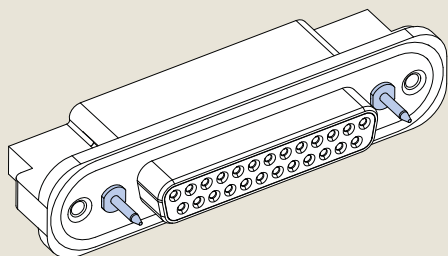

**G**

**Guide Pins**

Connector is supplied with stainless steel non-removable guide pins. Mates with type "B" guide sockets on mating connector.

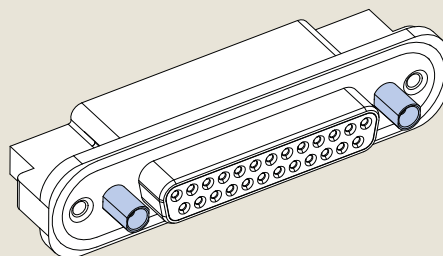

**B**

**Female Guide Bushing**

Connector is supplied with stainless steel non-removable bushings. Mates with type "G" guide pins on mating connector.

280-021S PANEL CUTOUTS

REAR PANEL MOUNT CUTOUT RECOMMENDATIONS AS VIEWED FROM FRONT FACE OF PANEL

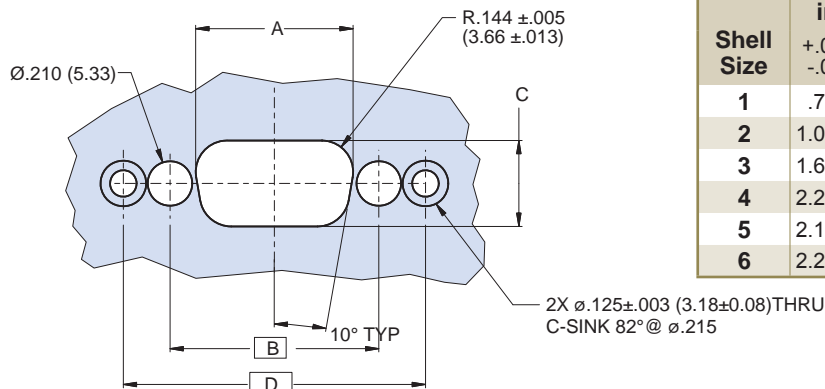

Shell Size	A		B Basic		C		D Basic	
	in	mm	in	mm	in.	mm	in	mm
1	.746	18.95	.984	24.99	.409	10.39	1.424	36.17
2	1.074	27.28	1.312	33.32	.409	10.39	1.752	44.50
3	1.614	41.00	1.852	47.04	.409	10.39	2.292	58.22
4	2.262	57.45	2.500	63.50	.409	10.39	2.940	74.68
5	2.159	54.84	2.406	61.11	.521	13.23	2.846	72.29
6	2.292	58.22	2.500	63.50	.583	14.81	2.940	74.68

Dimensions in inches (millimeters) and are subject to change without notice.

© 2011 Glenair, Inc.

CAGE Code 06324

Printed in U.S.A.

GLENAIR, INC. • 1211 AIR WAY • GLENDALE, CA 91201-2497 • 818-247-6000 • FAX 818-500-9912

www.glenair.com

E-9

E-Mail: sales@glenair.com

**280-031S**  
**Series 28 HiPer-D Float Mount Socket Connectors**  
**with Crimp Contacts**



**HiPer-D Float Mount Socket Connectors for Blind Mating**



**280-031S3S25MEG**

280-031S HiPer-D socket connectors feature stainless steel floating bushings for rack-to-panel or module-to-chassis mounting. Attach with #4-40 screws (not supplied with connector). Crimp, rear-releaseable size #20 or #22D contacts. Intermateable with standard M24308-type D-Subminiature connectors, the HiPer-D features a rugged machined aluminum shell and rubber grommet. Threaded holes on the rear of the connector allow attachment of HiPer-D EMI backshells. Contacts are packaged with connector. Terminate contacts with crimp tools purchased separately. Glass-reinforced thermoset epoxy insulators, copper alloy retention clips. Connector meets IP67 immersion requirement. 1000 VAC, 5 Amps (#22D) or 7.5 Amps (#20).

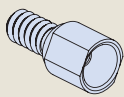
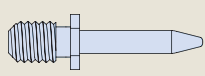
HOW TO ORDER				
Sample Part Number				
280-031S	4H62	MT	B	
Part Number	Shell Size - Insert Arr.	Shell Material/Finish	Hardware Option	
<p><b>280-031S</b> HiPer-D Float Mount Connector With Crimp Socket Contacts</p>	<p>Standard Density #20 Contacts</p> <p style="text-align: right;"><b>Contact Quantity</b></p> <p><b>Layout</b></p> <p><b>1S9</b> 9</p> <p><b>2S15</b> 15</p> <p><b>3S25</b> 25</p> <p><b>4S37</b> 37</p> <p><b>5S50</b> 50</p>	<p style="text-align: center;"><b>ME</b></p> <p>Aluminum with Electroless Nickel Finish <i>general purpose applications, excellent conductivity</i></p>	 <p style="text-align: center;"><b>N</b></p> <p>#8-32 Threaded Holes</p>	
	<p>High Density #22D Contacts</p> <p style="text-align: right;"><b>Contact Quantity</b></p> <p><b>Layout</b></p> <p><b>1H15</b> 15</p> <p><b>2H26</b> 26</p> <p><b>3H44</b> 44</p> <p><b>4H62</b> 62</p> <p><b>5H78</b> 78</p> <p><b>6H104</b> 104</p>	<p style="text-align: center;"><b>MT</b></p> <p>Aluminum with Nickel-PTFE Finish <i>1000 Hour Grey™ maximum corrosion protection, durability, and excellent conductivity (non-reflective grey)</i></p>	 <p style="text-align: center;"><b>B</b></p> <p>Female Guide Bushings</p>	
			<p style="text-align: center;"><b>JF</b></p> <p>Aluminum with Cadmium, Yellow Chromate <i>for severe environments, excellent conductivity</i></p>	 <p style="text-align: center;"><b>G</b></p> <p>Male Guide Pins</p>

SPECIFICATIONS	
Current Rating	#22D 5 AMPS, #20 7.5 AMPS
Test Voltage	1000 VAC RMS
Insulation Resistance	5000 megohms minimum
Operating Temperature	-65° C. to +200° C.
Ingress Protection	IP 67
Shock	300 g.
Vibration, Random	43.92 g.

MATERIALS AND FINISHES	
Shell	Aluminum alloy
Contacts	Copper alloy, 50 microinches gold plated
Insulators	Thermoset epoxy, glass-filled
Retention Clips	Beryllium copper alloy
Grommet	Fluorosilicone rubber
Hardware	300 series stainless steel

Dimensions in inches (millimeters) and are subject to change without notice.





# 280-031S

## Series 28 HiPer-D Float Mount Socket Connectors with Crimp Contacts

### HIPER-D CONTACT ARRANGEMENTS: STANDARD DENSITY, #20 CONTACTS

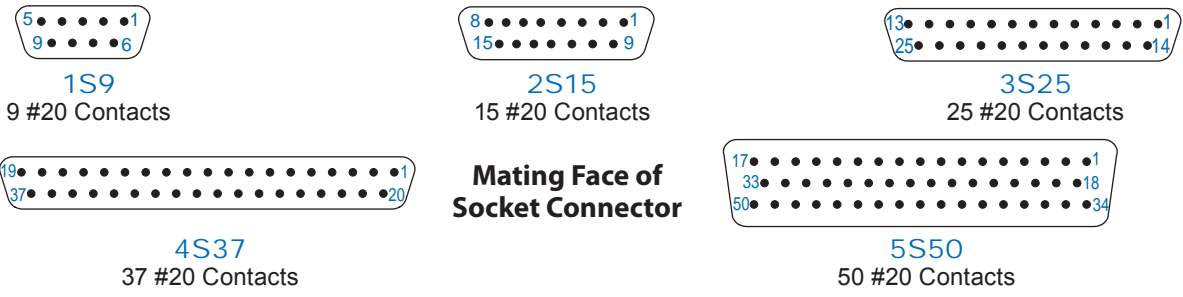

### HIPER-D CONTACT ARRANGEMENTS: HIGH DENSITY, #22D CONTACTS

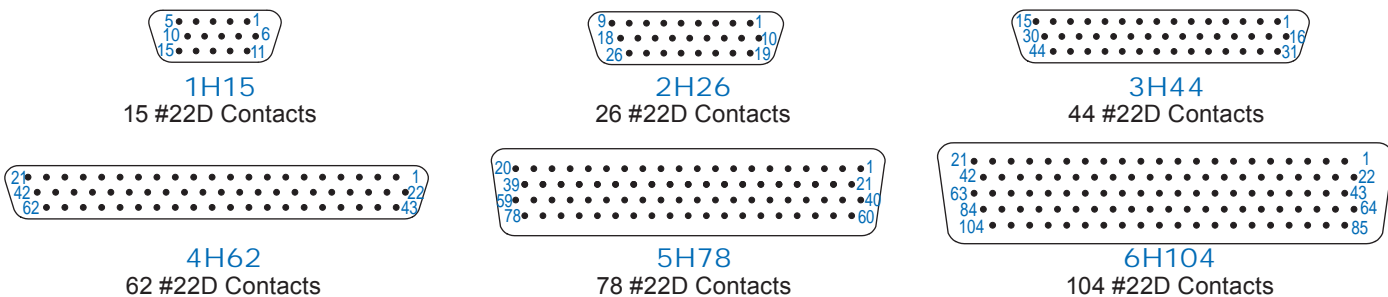

### 280-031S DIMENSIONS

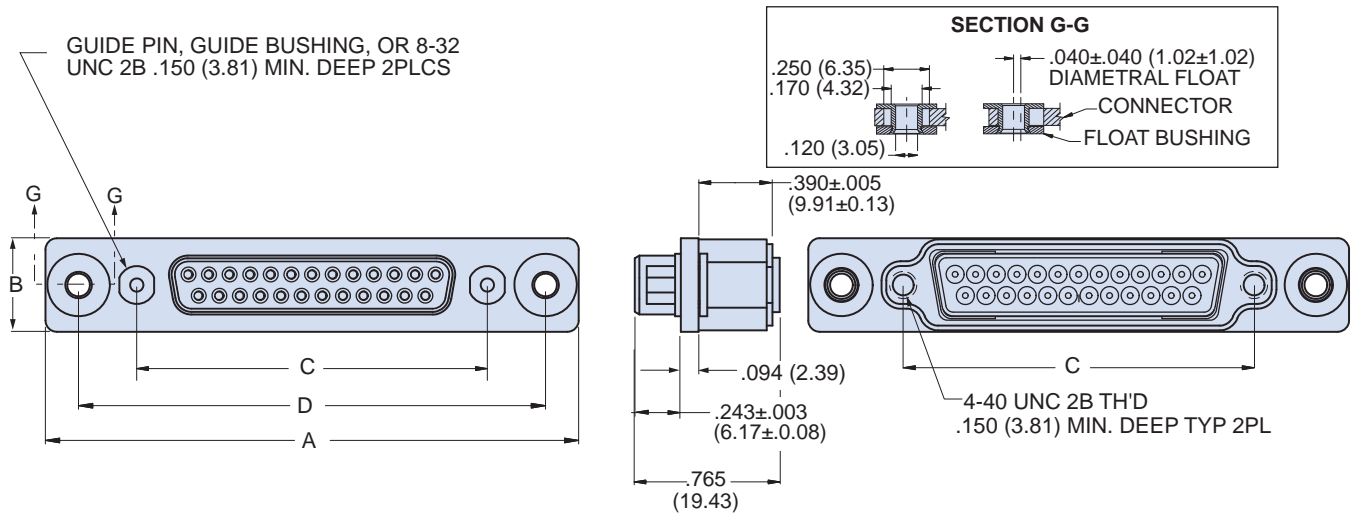

Shell Size	A		B		C Basic		D Basic	
	in ± .015	mm ± 0.38	in ± .015	mm ± 0.38	in.	mm	in	mm
1	1.986	50.44	.494	12.55	.984	24.99	1.636	41.55
2	2.314	58.78	.494	12.55	1.312	33.32	1.964	49.89
3	2.854	72.49	.494	12.55	1.852	47.04	2.504	63.60
4	3.502	88.95	.494	12.55	2.500	63.50	3.152	80.06
5	3.408	86.56	.600	15.24	2.406	61.11	3.058	77.67
6	3.502	88.95	.662	16.81	2.500	63.50	3.152	80.06

Dimensions in inches (millimeters) and are subject to change without notice.

CAGE Code 06324

Printed in U.S.A.

© 2011 Glenair, Inc. **GLENAIR, INC. • 1211 AIR WAY • GLENDALE, CA 91201-2497 • 818-247-6000 • FAX 818-500-9912**

**280-031S**  
**Series 28 HiPer-D Float Mount Socket Connectors**  
**with Crimp Contacts**

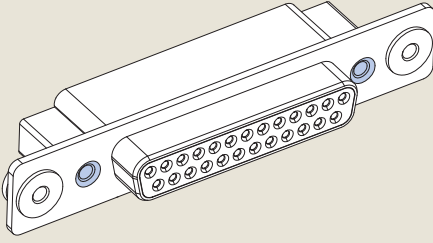
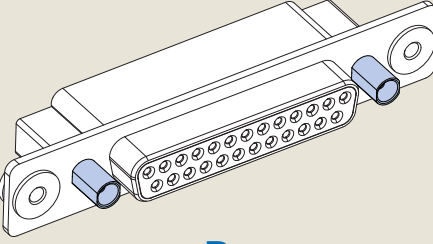
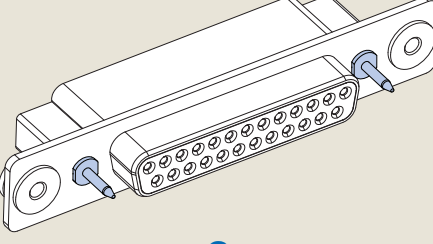

**HARDWARE OPTION**

 <p><b>N</b>  <b>No Mating Hardware</b>  Connector is supplied with threaded holes. Holes are #8-32 UNC 2B, .150 (3.81) min. deep.</p>	 <p><b>B</b>  <b>Female Guide Bushing</b>  Connector is supplied with non-removable female guide bushings. Mates with type "G" guide pins on mating connector. Stainless steel.</p>	 <p><b>G</b>  <b>Guide Pins</b>  Connector is supplied with stainless steel non-removable guide pins. Mates with type "B" guide sockets on mating connector.</p>
---	---	---

**280-031S PANEL CUTOUTS**

REAR PANEL CUTOUT VIEWED FROM FRONT OF PANEL

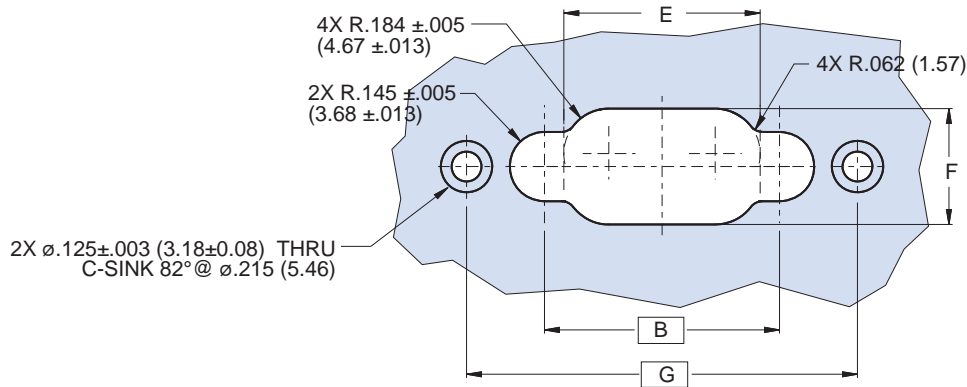

Shell Size	B Basic		E		F		G Basic	
	in	mm	in	mm	in.	mm	in	mm
1	.984	24.99	.826	20.98	.489	12.42	1.636	41.55
2	1.312	33.32	1.154	29.31	.489	12.42	1.964	49.89
3	1.852	47.04	1.694	43.03	.489	12.42	2.504	63.60
4	2.500	63.50	2.342	59.49	.489	12.42	3.152	80.06
5	2.406	61.11	2.239	56.87	.601	15.27	3.058	77.67
6	2.500	63.50	2.372	60.25	.663	16.84	3.152	80.06

Dimensions in inches (millimeters) and are subject to change without notice.

CAGE Code 06324

Printed in U.S.A.

© 2011 Glenair, Inc.

**GLENAIR, INC. • 1211 AIR WAY • GLENDALE, CA 91201-2497 • 818-247-6000 • FAX 818-500-9912**

www.glenair.com

E-Mail: sales@glenair.com

### HiPer-D Panel Mount Pin Connectors with Straight PC Tails

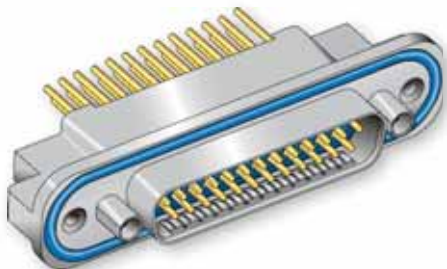

Rear panel mount HiPer-D pin connectors feature non-removable size #20 or #22D straight PC tail contacts and a flange O-ring for a watertight panel seal. Intermateable with standard M24308-type D-Subminiature connectors, the HiPer-D features a rugged machined shell, waterproof sealing and optional ground springs for improved resistance to electromagnetic interference. #4-40 threaded mounting holes simplify panel attachment. Threaded holes on the rear of the connector allow attachment to circuit board. Contacts are gold plated and potted with epoxy. Aluminum shell. Glass-reinforced thermoset epoxy insulators, fluorosilicone face seal. 1000 VAC, 5 Amps (#22D) or 7.5 Amps (#20).

#### HOW TO ORDER

##### Sample Part Number

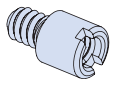
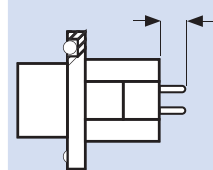
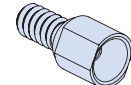
280-022P	4S37	ME	G	B	A	
Part Number	Shell Size - Insert Arr.	Shell Material/Finish	EMI Spring	Hardware Option	PC Tail Length	
<b>280-022P</b> HiPer-D Panel Mount Pin Connector With Straight PC Tails	Standard Density #20 Contacts	<b>ME</b> Aluminum with Electroless Nickel Finish <i>general purpose applications, excellent conductivity</i>	<b>G</b> EMI Spring	 <b>N</b> #8-32 Threaded Hole	<b>A</b> .125 inches (3.18 mm)	
	Layout		Contact Quantity		<b>N</b> No Spring	<b>B</b> .250 inches (6.35 mm)
	<b>1S9</b>		9	<b>MT</b> Aluminum with Nickel-PTFE Finish <i>1000 Hour Grey™ maximum corrosion protection, durability, and excellent conductivity (non-reflective grey)</i>	 <b>P</b> #4-40 Female Jackpost	
	<b>2S15</b>		15			
	<b>3S25</b>		25			
	<b>4S37</b>		37			
	<b>5S50</b>	50	<b>JF</b> Aluminum with Cadmium, Yellow Chromate <i>for severe environments, excellent conductivity</i>	 <b>B</b> Female Guide Bushing for Blind Mating		
	High Density #22D Contacts	<b>JF</b> Aluminum with Cadmium, Yellow Chromate <i>for severe environments, excellent conductivity</i>			Layout	Contact Quantity
	<b>1H15</b>				15	
	<b>2H26</b>				26	
	<b>3H44</b>				44	
	<b>4H62</b>				62	
<b>5H78</b>	78					
<b>6H104</b>	104					

#### SPECIFICATIONS

Current Rating	#22D 5 AMPS, #20 7.5 AMPS
Test Voltage	1000 VAC RMS
Insulation Resistance	5000 megohms minimum
Operating Temperature	-65° C. to +200° C.
Ingress Protection	IP 67
Shock	300 g.
Vibration, Random	43.92 g.

#### MATERIALS AND FINISHES

Shell	6061 Aluminum or 300 Series SST
Contacts	Copper alloy, 50 microinches gold plated
Insulators	Thermoset epoxy
Potting Compound	Epoxy
Face Seal	Fluorosilicone rubber
Hardware	300 series stainless steel

Dimensions in inches (millimeters) and are subject to change without notice.

# 280-022P Series 28 HiPer-D Panel Mount Pin PCB Connectors with Straight PC Tails



## HIPER-D CONTACT ARRANGEMENTS: STANDARD DENSITY, #20 CONTACTS

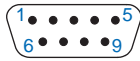

**1S9**  
9 #20 Contacts

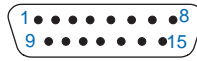

**2S15**  
15 #20 Contacts

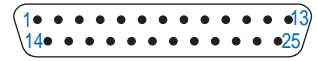

**3S25**  
25 #20 Contacts

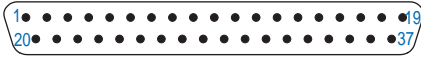

**4S37**  
37 #20 Contacts

**Mating Face of Pin Connector**



**5S50**  
50 #20 Contacts

## HIPER-D CONTACT ARRANGEMENTS: HIGH DENSITY, #22D CONTACTS

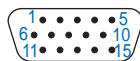

**1H15**  
15 #22D Contacts

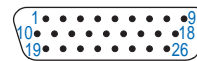

**2H26**  
26 #22D Contacts

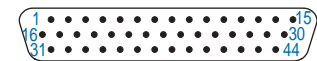

**3H44**  
44 #22D Contacts

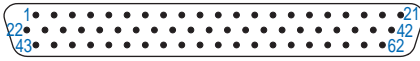

**4H62**  
62 #22D Contacts

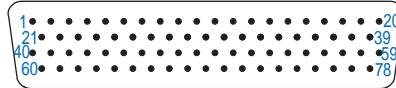

**5H78**  
78 #22D Contacts



**6H104**  
104 #22D Contacts

**Mating Face of Pin Connector**

## HARDWARE OPTION

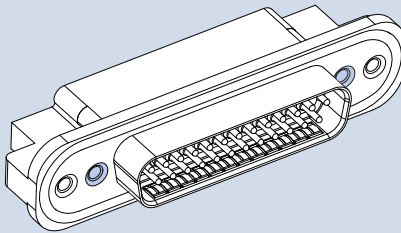

**N**  
**No Mating Hardware**

Connector is supplied without mating hardware. Hardware attachment holes are #8-32 UNC 2B, .150 min. deep.

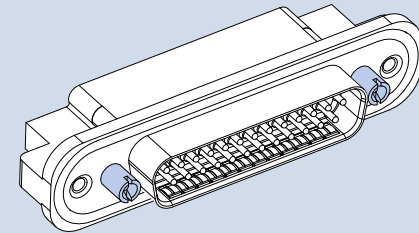

**P**  
**Jackposts**

Connector is supplied with non-removable stainless steel jackposts. #4-40 UNC 2B thread. Stainless steel.

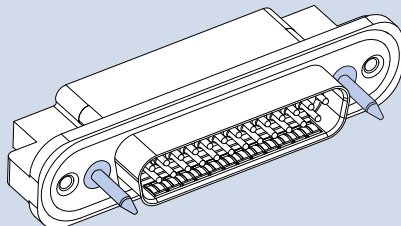

**G**  
**Guide Pins**

Connector is supplied with stainless steel non-removable guide pins. Mates with type "B" guide bushings on mating connector.

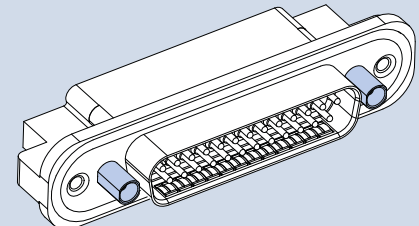

**B**  
**Female Guide Bushing**

Connector is supplied with stainless steel non-removable bushings. Mates with type "G" guide pins on mating connector.

Dimensions in inches (millimeters) and are subject to change without notice.





# 280-022P

## Series 28 HiPer-D Panel Mount Pin PCB Connectors with Straight PC Tails

### 280-022P DIMENSIONS

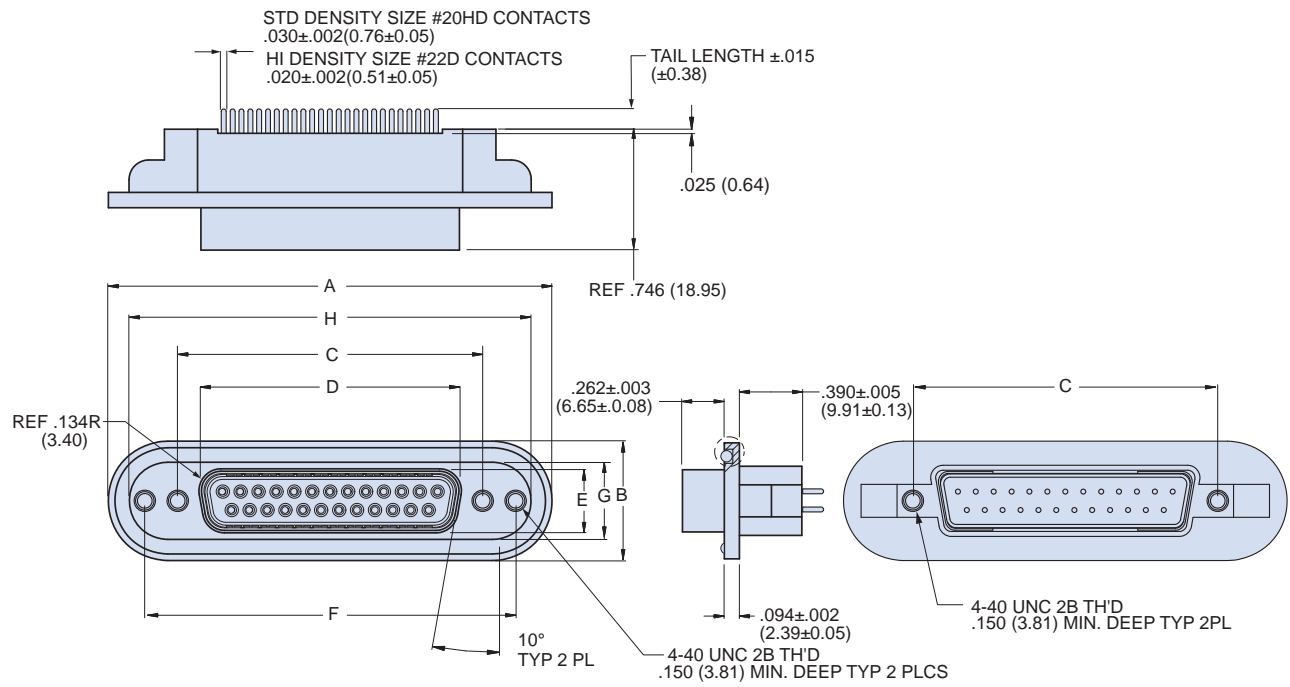

Shell Size	A		B		C Basic		D		E		F Basic		G		H	
	in	mm	in	mm	in.	mm	in	mm	in	mm	in	mm	in	mm	in	mm
1	1.865	47.37	.725	18.42	.984	24.99	.726	18.44	.389	9.88	1.424	36.17	.469	11.91	1.609	40.87
2	2.200	55.88	.725	18.42	1.312	33.32	1.054	26.77	.389	9.88	1.752	44.50	.469	11.91	1.944	49.38
3	2.736	69.49	.725	18.42	1.852	47.04	1.594	40.49	.389	9.88	2.292	58.22	.469	11.91	2.480	62.99
4	3.385	85.98	.725	18.42	2.500	63.50	2.242	56.95	.389	9.88	2.940	74.68	.469	11.91	3.129	79.48
5	3.289	83.54	.837	21.26	2.406	61.11	2.139	54.33	.501	12.73	2.846	72.29	.581	14.76	3.033	77.04
6	3.383	85.93	.899	22.83	2.500	63.50	2.272	57.71	.563	14.30	2.940	74.68	.643	16.33	3.127	79.43

### 280-022P PANEL CUTOUT

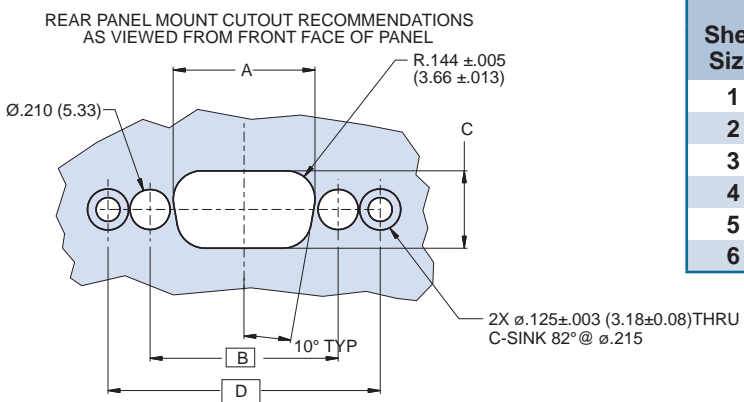

Shell Size	A		B Basic		C		D Basic	
	in	mm	in	mm	in.	mm	in	mm
1	.746	18.95	.984	24.99	.409	10.39	1.424	36.17
2	1.074	27.28	1.312	33.32	.409	10.39	1.752	44.50
3	1.614	41.00	1.852	47.04	.409	10.39	2.292	58.22
4	2.262	57.45	2.500	63.50	.409	10.39	2.940	74.68
5	2.159	54.84	2.406	61.11	.521	13.23	2.846	72.29
6	2.292	58.22	2.500	63.50	.583	14.81	2.940	74.68

Dimensions in inches (millimeters) and are subject to change without notice.

# 280-026P Series 28 HiPer-D Free-Standing PCB Pin Connectors with Straight PC Tails



## Free-Standing PCB Pin Connectors

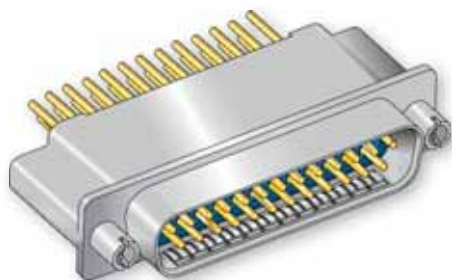

Free-standing HiPer-D pin connectors feature non-removable size #20 or #22D straight PC tail contacts. Intermateable with standard M24308-type D-Subminiature connectors, the HiPer-D features a rugged machined shell, waterproof sealing and optional ground springs for improved resistance to electromagnetic interference. Threaded holes on the rear of the connector allow attachment to circuit board. Contacts are potted with epoxy. Aluminum shell. Glass-reinforced thermoset epoxy insulators, fluorosilicone face seal. 1000 VAC, 5 Amps (#22D) or 7.5 Amps (#20).

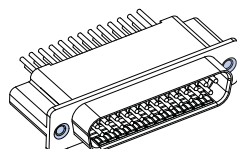
HOW TO ORDER					
Sample Part Number					
280-026P	2H26	ME	N	P	A
Part Number	Shell Size - Insert Arr.	Shell Material/Finish	EMI Spring	Hardware Option	PC Tail Length
<b>280-026P</b> HiPer-D Free-Standing Pin Connector With Straight PC Tails	Standard Density #20 Contacts Contact Quantity Layout <b>1S9</b> 9 <b>2S15</b> 15 <b>3S25</b> 25 <b>4S37</b> 37 <b>5S50</b> 50	<b>ME</b> Aluminum with Electroless Nickel Finish <i>general purpose applications, excellent conductivity</i>  <b>MT</b> Aluminum with Nickel-PTFE Finish <i>1000 Hour Grey™ maximum corrosion protection, durability, and excellent conductivity (non-reflective grey)</i>	<b>G</b> EMI Spring  <b>N</b> No Spring	 <b>N</b> #4-40 Female Threads in Mounting Holes Choose this option for rear panel mounting and order jackpost kit 289-016 separately.	<b>A</b> .125 inches (3.18 mm)  <b>B</b> .250 inches (6.35 mm)
	High Density #22D Contacts Contact Quantity Layout <b>1H15</b> 15 <b>2H26</b> 26 <b>3H44</b> 44 <b>4H62</b> 62 <b>5H78</b> 78 <b>6H104</b> 104				

SPECIFICATIONS	
Current Rating	#22D 5 AMPS, #20 7.5 AMPS
Test Voltage	1000 VAC RMS
Insulation Resistance	5000 megohms minimum
Operating Temperature	-65° C. to +200° C.
Ingress Protection	IP 67
Shock	300 g.
Vibration, Random	43.92 g.

MATERIALS AND FINISHES	
Shell	6061 Aluminum or 300 Series SST
Contacts	Copper alloy, 50 microinches gold plated
Insulators	Thermoset epoxy
Potting Compound	Epoxy
Face Seal	Fluorosilicone rubber
Hardware	300 series stainless steel

Dimensions in inches (millimeters) and are subject to change without notice.



# 280-026P

## Series 28 HiPer-D Free-Standing PCB Pin Connectors with Straight PC Tails

### HIPER-D CONTACT ARRANGEMENTS: STANDARD DENSITY, #20 CONTACTS

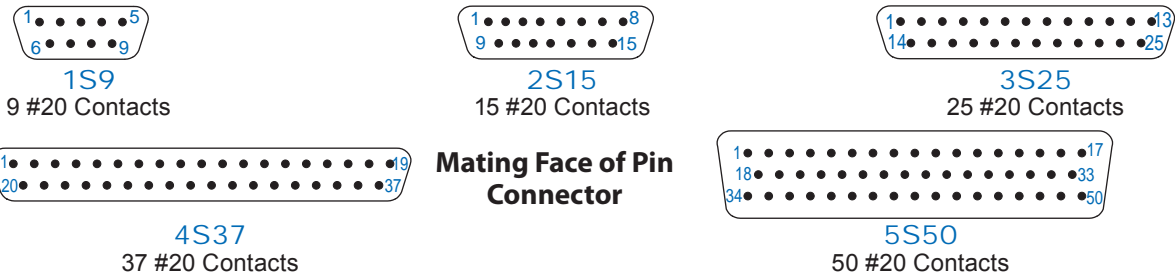

### HIPER-D CONTACT ARRANGEMENTS: HIGH DENSITY, #22D CONTACTS

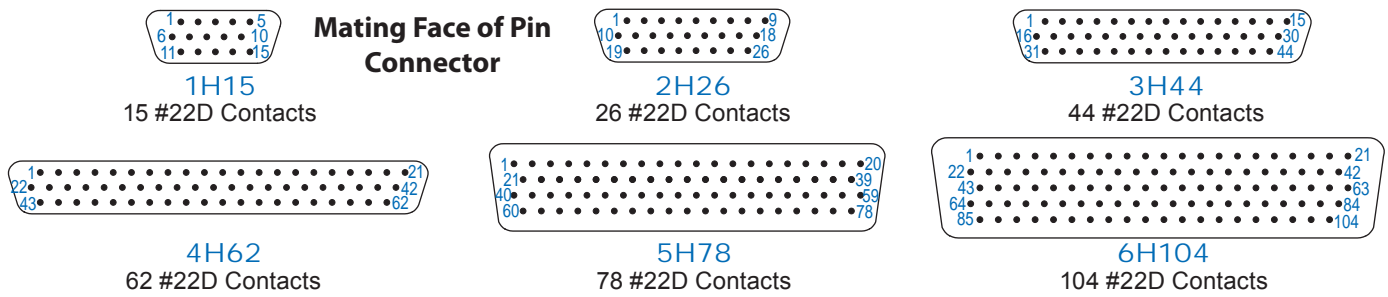

### 280-026P DIMENSIONS

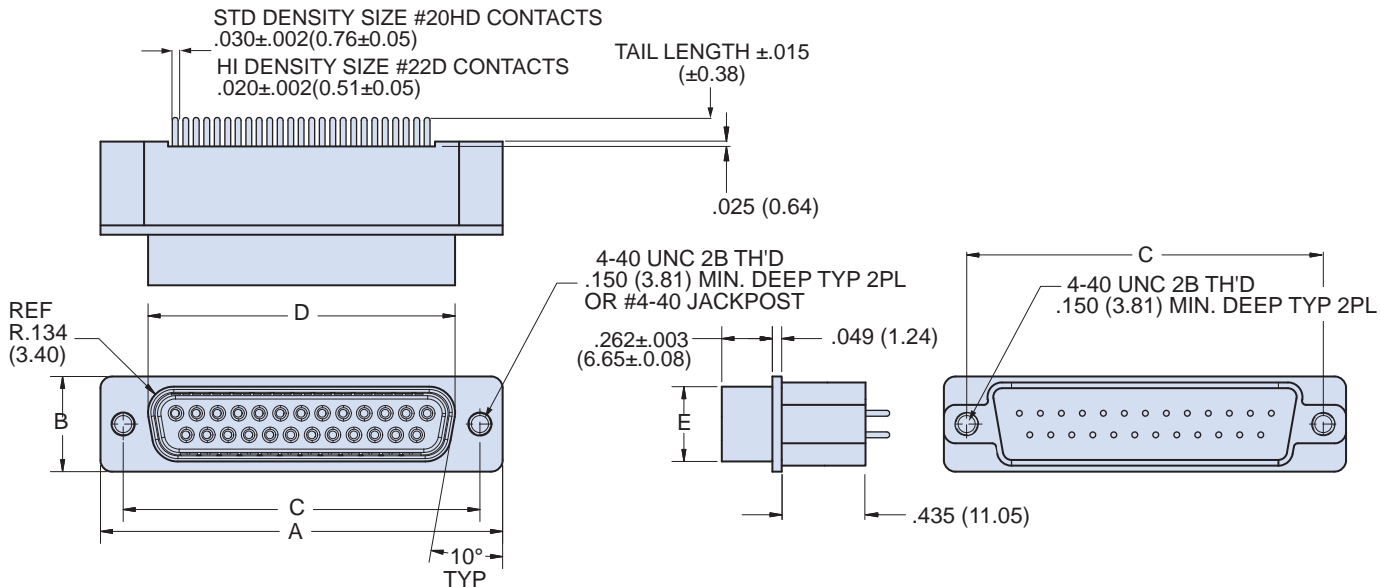

Shell Size	A		B		C Basic		D		E	
	in ± .015	mm ± 0.38	in ± .015	mm ± 0.38	in	mm	in ± .005	mm ± 0.13	in ± .005	mm ± 0.13
1	1.213	30.81	.494	12.55	.984	24.99	.726	18.44	.389	9.88
2	1.541	39.14	.494	12.55	1.312	33.32	1.054	26.77	.389	9.88
3	2.088	53.04	.494	12.55	1.852	47.04	1.594	40.49	.389	9.88
4	2.729	69.32	.494	12.55	2.500	63.50	2.242	56.95	.389	9.88
5	2.635	66.93	.605	15.37	2.406	61.11	2.139	54.33	.501	12.73
6	2.729	69.32	.668	16.97	2.500	63.50	2.272	57.71	.563	14.30

Dimensions in inches (millimeters) and are subject to change without notice.

280-022P and 280-026P  
 Series 28 HiPer-D Free-Standing PCB Pin Connectors  
 with Straight PC Tails



280-022P AND 280-026P PRINTED CIRCUIT BOARD PATTERNS

Component Mounting Side of PCB

1S9  
9 #20

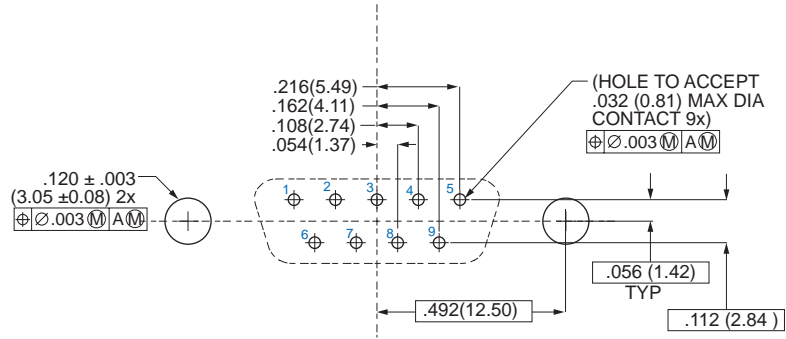

2S15  
15 #20

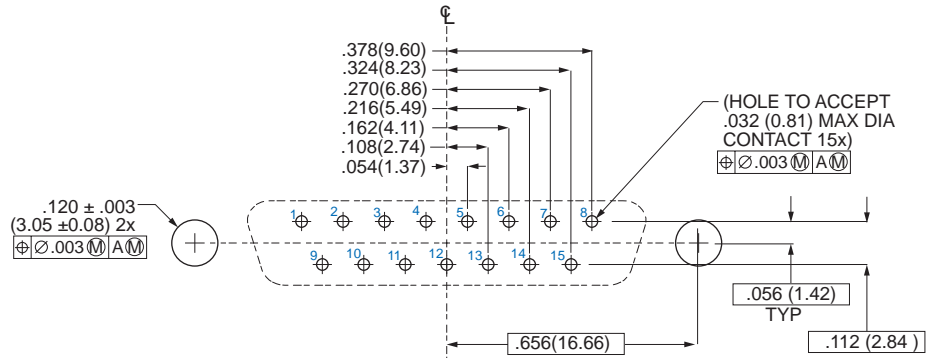

3S25  
25 #20

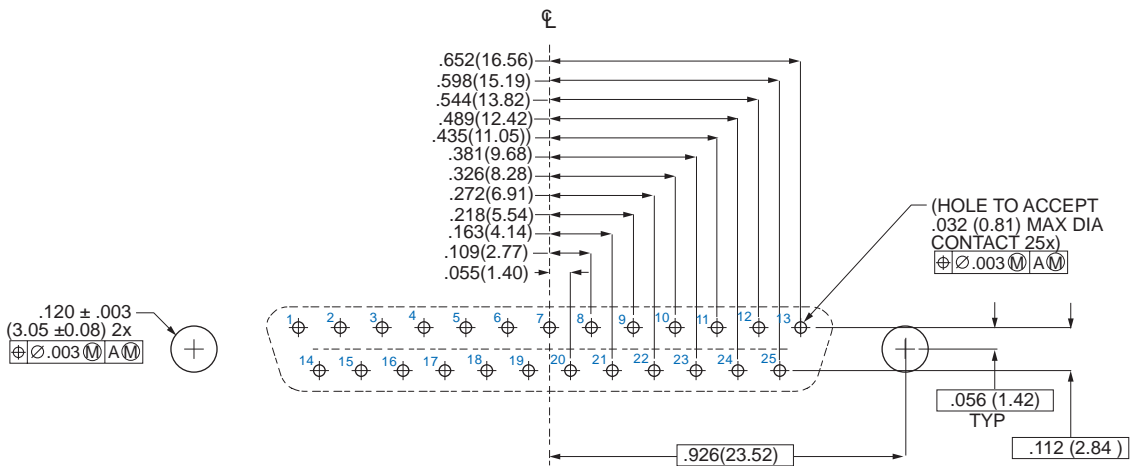

Dimensions in inches (millimeters) and are subject to change without notice.



280-022P AND 280-026P PRINTED CIRCUIT BOARD PATTERNS

Component Mounting Side of PCB

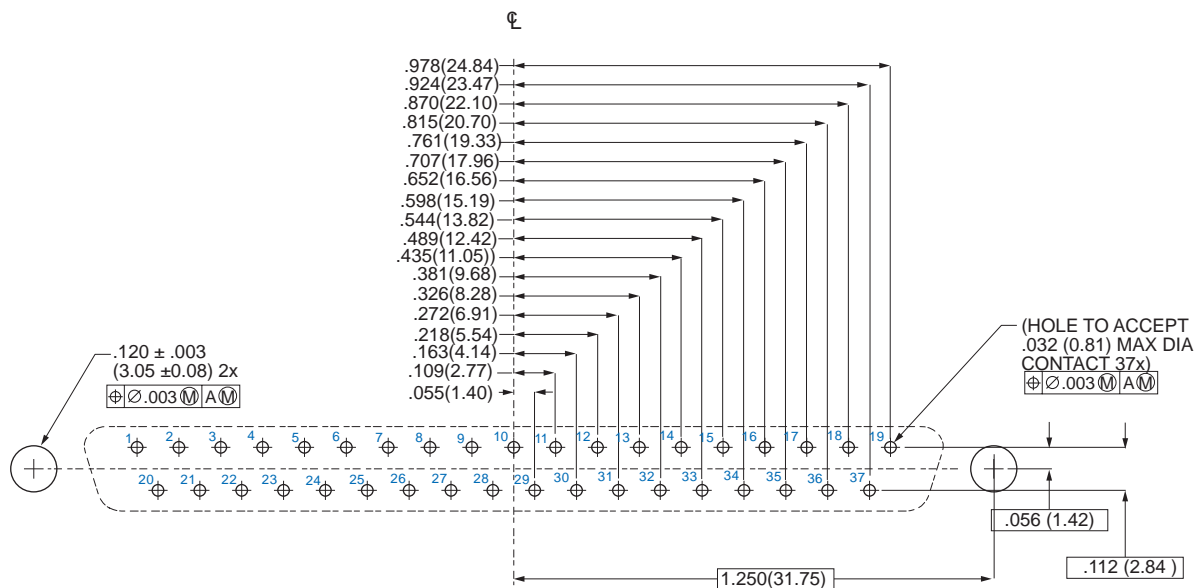

**4S37**  
37 #20

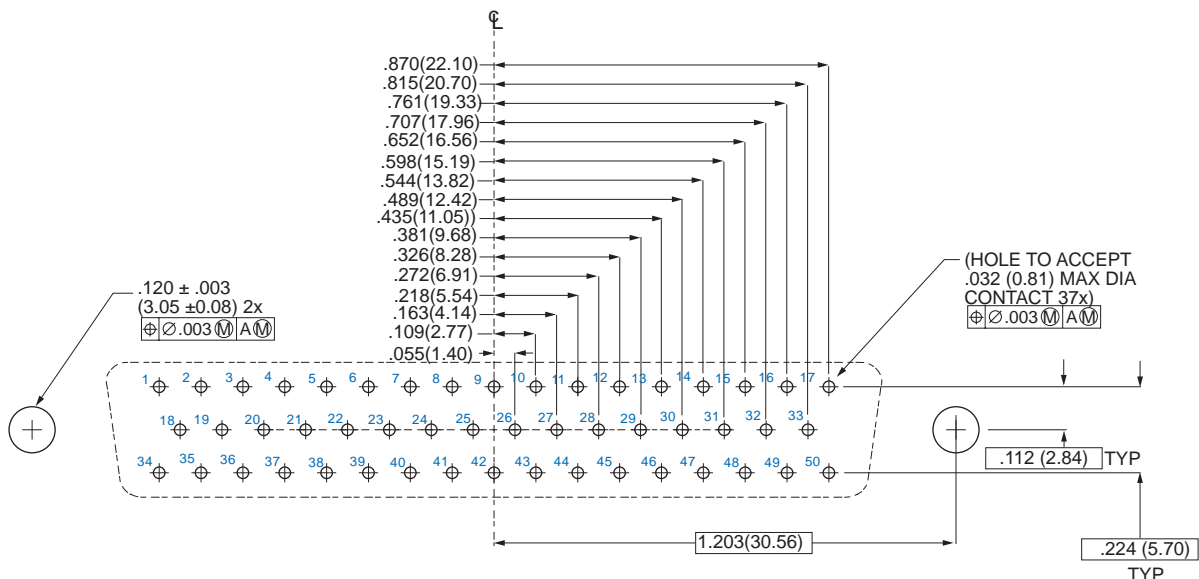

**5S50**  
50 #20

Dimensions in inches (millimeters) and are subject to change without notice.

280-022P and 280-026P  
Series 28 HiPer-D Free-Standing PCB Pin Connectors  
with Straight PC Tails



280-022P AND 280-026P PRINTED CIRCUIT BOARD PATTERNS

Component Mounting Side of PCB

1H15  
15 #22D

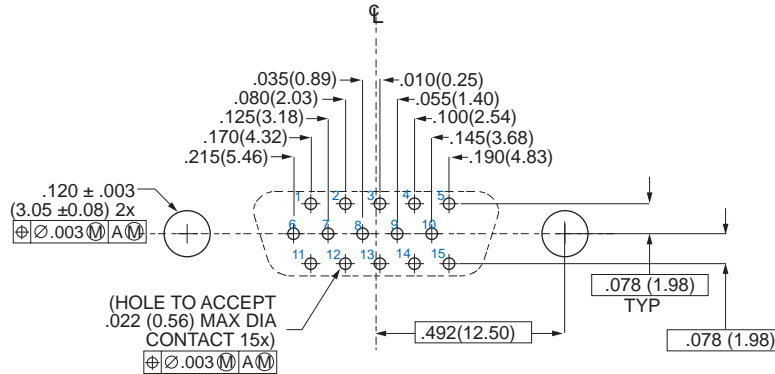

2H26  
26 #22D

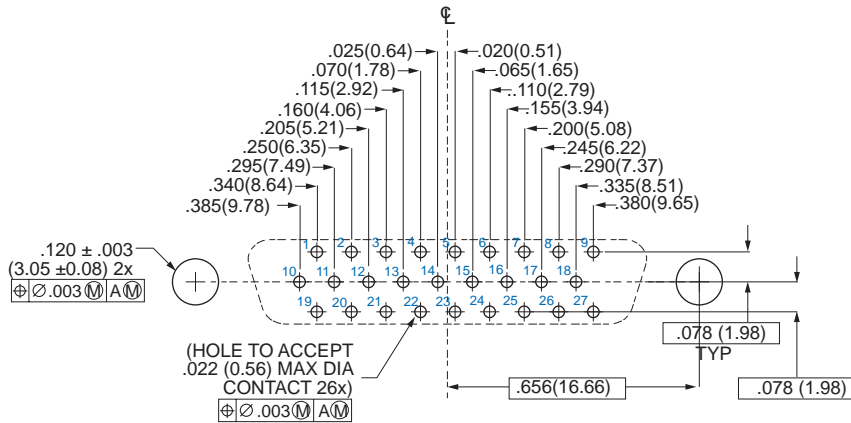

3H44  
44 #22D

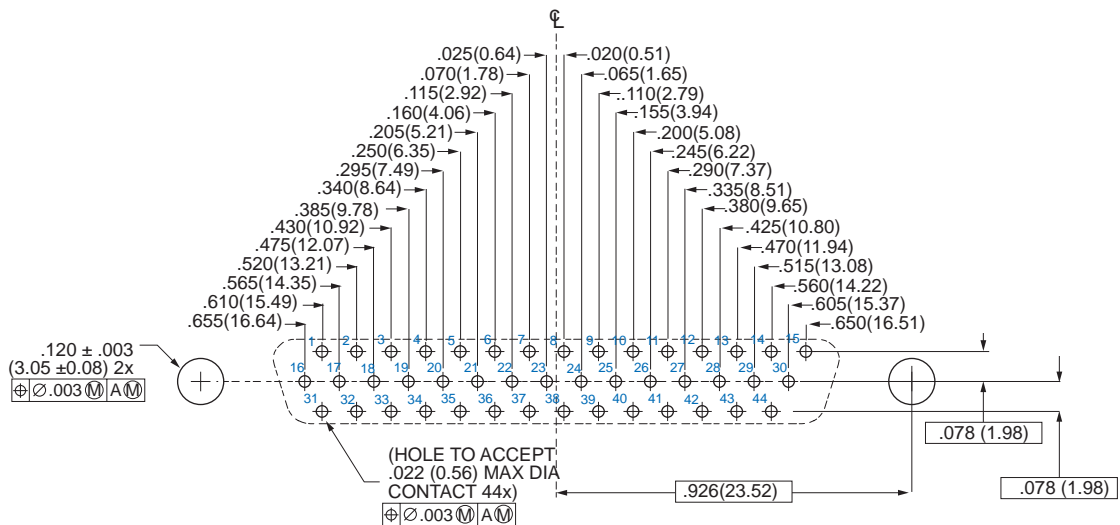

Dimensions in inches (millimeters) and are subject to change without notice.

CAGE Code 06324

Printed in U.S.A.



# 280-022P and 280-026P Series 28 HiPer-D Free-Standing PCB Pin Connectors with Straight PC Tails

## 280-022P AND 280-026P PRINTED CIRCUIT BOARD PATTERNS

### Component Mounting Side of PCB

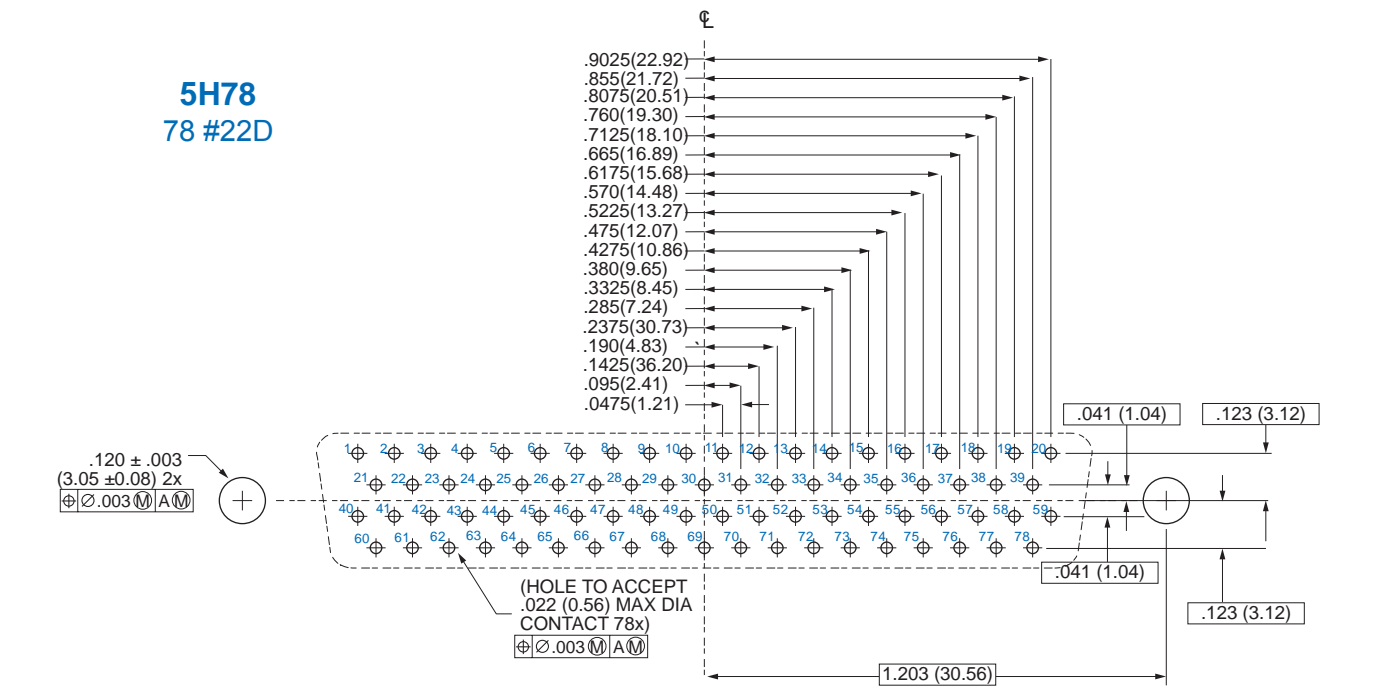
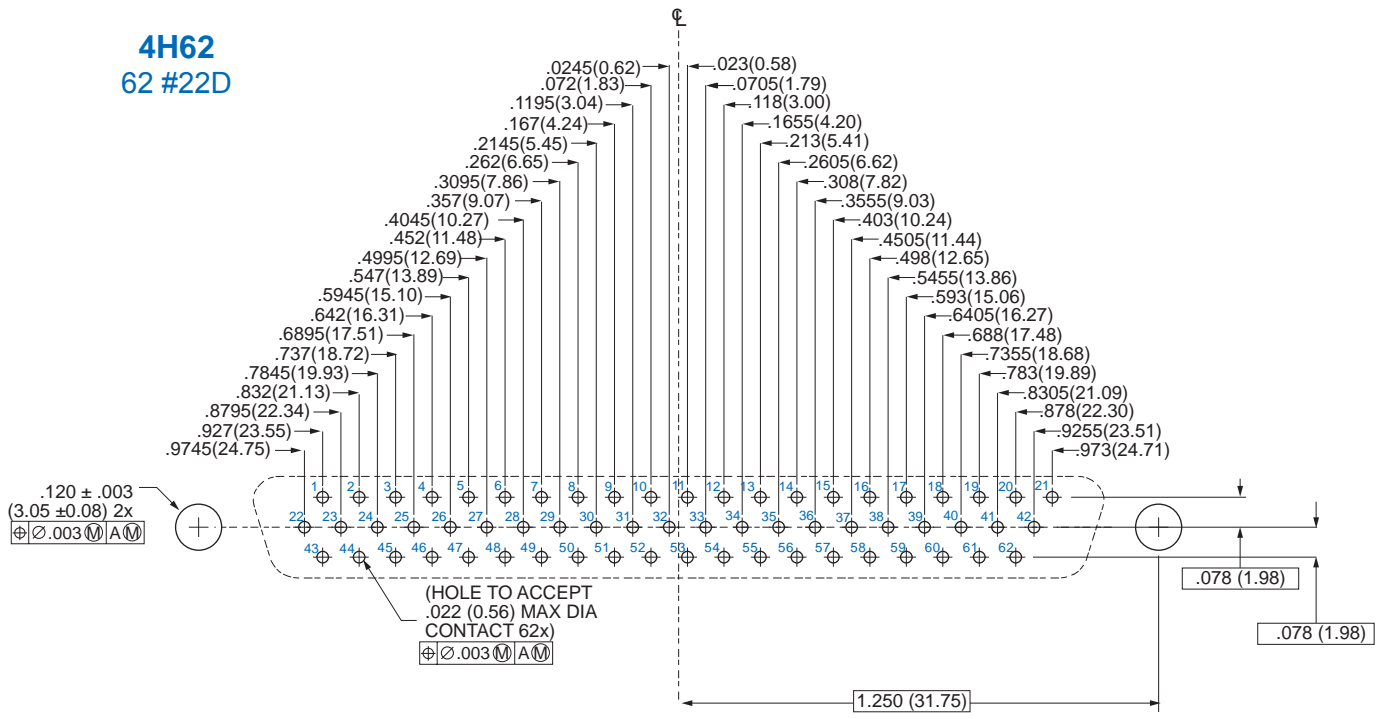

Dimensions in inches (millimeters) and are subject to change without notice.

**280-022P and 280-026P**  
**Series 28 HiPer-D Free-Standing PCB Pin Connectors**  
**with Straight PC Tails**



**280-022P AND 280-026P PRINTED CIRCUIT BOARD PATTERNS**

**Component Mounting Side of PCB**

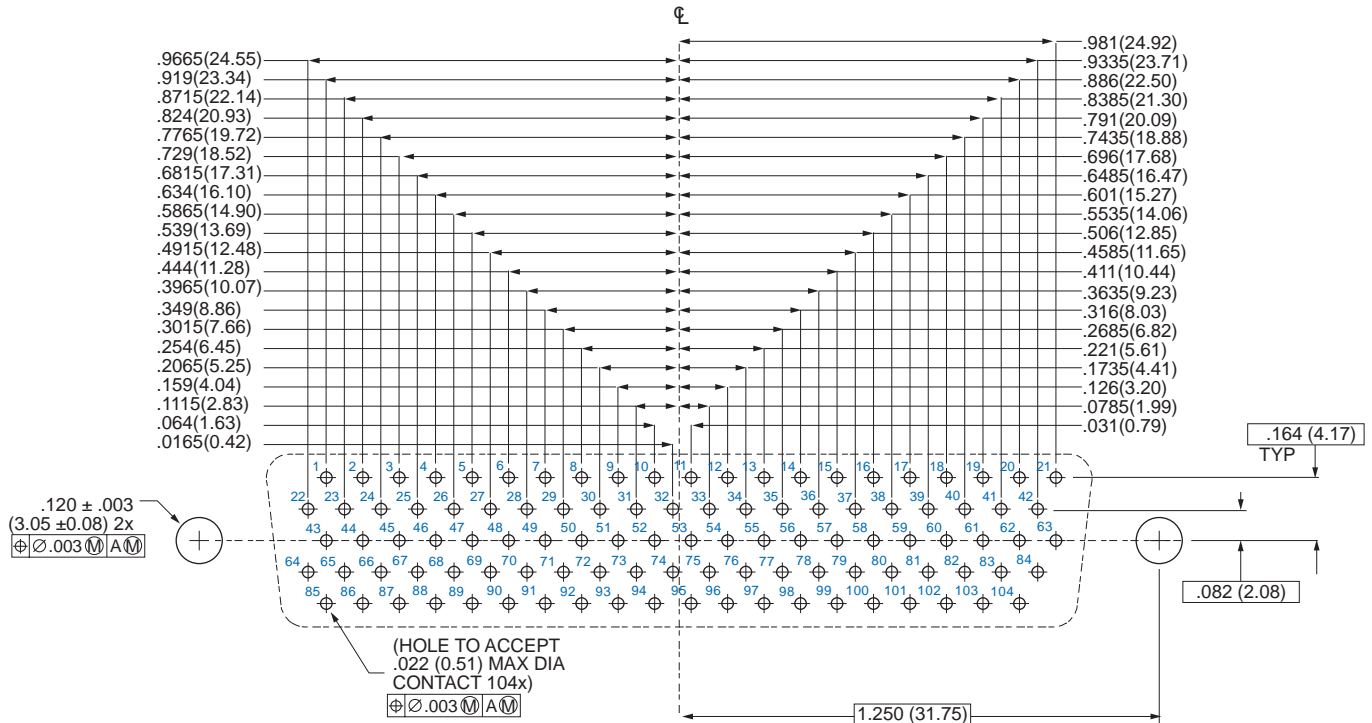

**6H104**  
**104 #22D**

Dimensions in inches (millimeters) and are subject to change without notice.



### HiPer-D Panel Mount Socket Connectors with Straight PC Tails

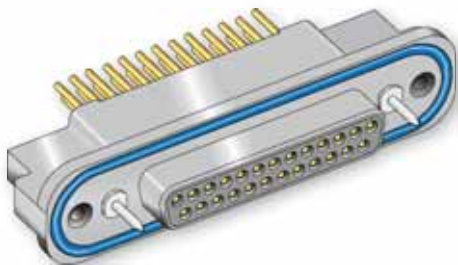

Rear panel mount HiPer-D socket connectors feature non-removable size #20 or #22D straight PC tail contacts and a flange O-ring for a watertight panel seal. Intermateable with standard M24308-type D-Subminiature connectors, the HiPer-D features a rugged machined shell, waterproof sealing and optional ground springs for improved resistance to electromagnetic interference. #4-40 threaded mounting holes simplify panel attachment. Threaded holes on the rear of the connector allow attachment to circuit board. Contacts are potted with epoxy. Aluminum shell. Glass-reinforced thermoset epoxy insulators. 1000 VAC, 5 Amps (#22D) or 7.5 Amps (#20).

#### HOW TO ORDER

##### Sample Part Number

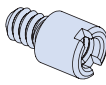
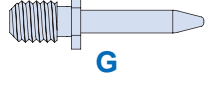
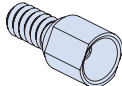
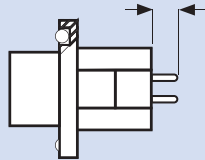
280-023S	4S37	ME	B	A						
Part Number	Shell Size - Insert Arr.	Shell Material/Finish	Hardware Option	PC Tail Length						
<b>280-023S</b> HiPer-D Panel Mount Socket Connector With Straight PC Tails	Standard Density #20 Contacts	<b>ME</b> Aluminum with Electroless Nickel Finish <i>general purpose applications,            excellent conductivity</i>	 <b>N</b> #8-32 Threaded Hole	<b>A</b> .125 inches (3.18 mm)						
	<b>Layout</b>				<b>MT</b> Aluminum with Nickel-PTFE Finish <i>1000 Hour Grey™            maximum corrosion            protection, durability, and            excellent conductivity            (non-reflective grey)</i>	 <b>P</b> #4-40 Female Jackpost	<b>B</b> .250 inches (6.35 mm)			
	<b>Contact Quantity</b>							<b>JF</b> Aluminum with Cadmium, Yellow Chromate <i>for severe environments,            excellent conductivity</i>	 <b>G</b> Male Guide Pin for Blind Mating	
	<b>1S9</b> 9									 <b>B</b> Female Guide Bushing for Blind Mating
	<b>2S15</b> 15									
	<b>3S25</b> 25									
	<b>4S37</b> 37									
	<b>5S50</b> 50									
	High Density #22D Contacts	<b>JF</b> Aluminum with Cadmium, Yellow Chromate <i>for severe environments,            excellent conductivity</i>	<b>G</b> Male Guide Pin for Blind Mating							
	<b>Layout</b>									
	<b>Contact Quantity</b>									
	<b>1H15</b> 15									
<b>2H26</b> 26										
<b>3H44</b> 44										
<b>4H62</b> 62										
<b>5H78</b> 78										
<b>6H104</b> 104										

#### SPECIFICATIONS

Current Rating	#22D 5 AMPS, #20 7.5 AMPS
Test Voltage	1000 VAC RMS
Insulation Resistance	5000 megohms minimum
Operating Temperature	-65° C. to +200° C.
Shock	300 g.
Vibration, Random	43.92 g.

#### MATERIALS AND FINISHES

Shell	6061 Aluminum
Contacts	Copper alloy, 50 microinches gold plated
Insulators	Thermoset epoxy
Potting Compound	Epoxy
Hardware	300 series stainless steel

Dimensions in inches (millimeters) and are subject to change without notice.

# 280-023S Series 28 HiPer-D Panel Mount Socket PCB Connectors with Straight PC Tails



## HIPER-D CONTACT ARRANGEMENTS: STANDARD DENSITY, #20 CONTACTS

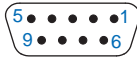

**1S9**  
9 #20 Contacts

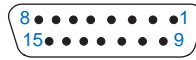

**2S15**  
15 #20 Contacts

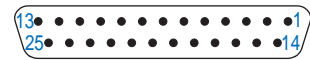

**3S25**  
25 #20 Contacts

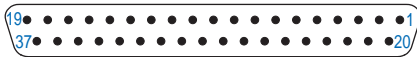

**4S37**  
37 #20 Contacts

**Mating Face of  
Socket Connector**

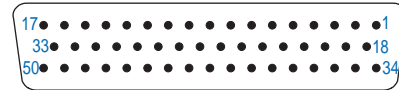

**5S50**  
50 #20 Contacts

## HIPER-D CONTACT ARRANGEMENTS: HIGH DENSITY, #22D CONTACTS

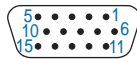

**1H15**  
15 #22D Contacts

**Mating Face of  
Socket Connector**

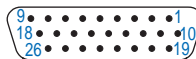

**2H26**  
26 #22D Contacts

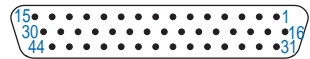

**3H44**  
44 #22D Contacts



**4H62**  
62 #22D Contacts

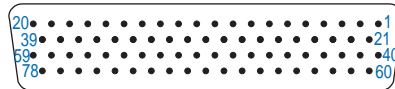

**5H78**  
78 #22D Contacts

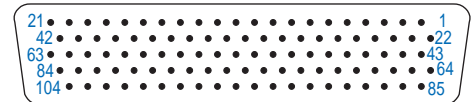

**6H104**  
104 #22D Contacts

## HARDWARE OPTION

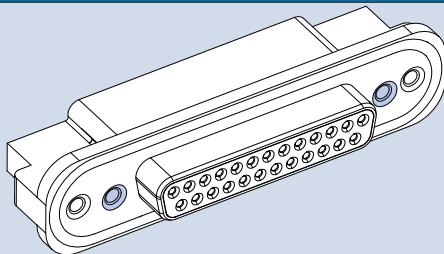

**N**  
**No Mating Hardware**

Connector is supplied without mating hardware. Hardware attachment holes are #8-32 UNC 2B, .150 min. deep.

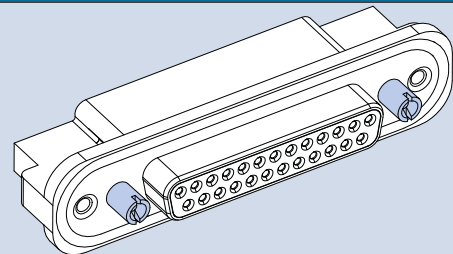

**P**  
**Jackposts**

Connector is supplied with non-removable stainless steel jackposts. #4-40 UNC 2B thread. Stainless steel.

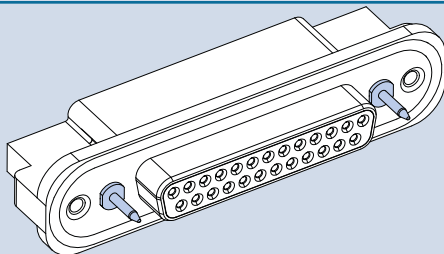

**G**  
**Guide Pins**

Connector is supplied with stainless steel non-removable guide pins. Mates with type "B" guide sockets on mating connector.

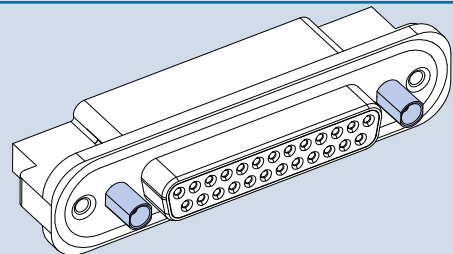

**B**  
**Female Guide Bushing**

Connector is supplied with stainless steel non-removable bushings. Mates with type "G" guide pins on mating connector.

Dimensions in inches (millimeters) and are subject to change without notice.



# 280-023S

## Series 28 HiPer-D Panel Mount Socket PCB Connectors with Straight PC Tails

### 280-023S DIMENSIONS

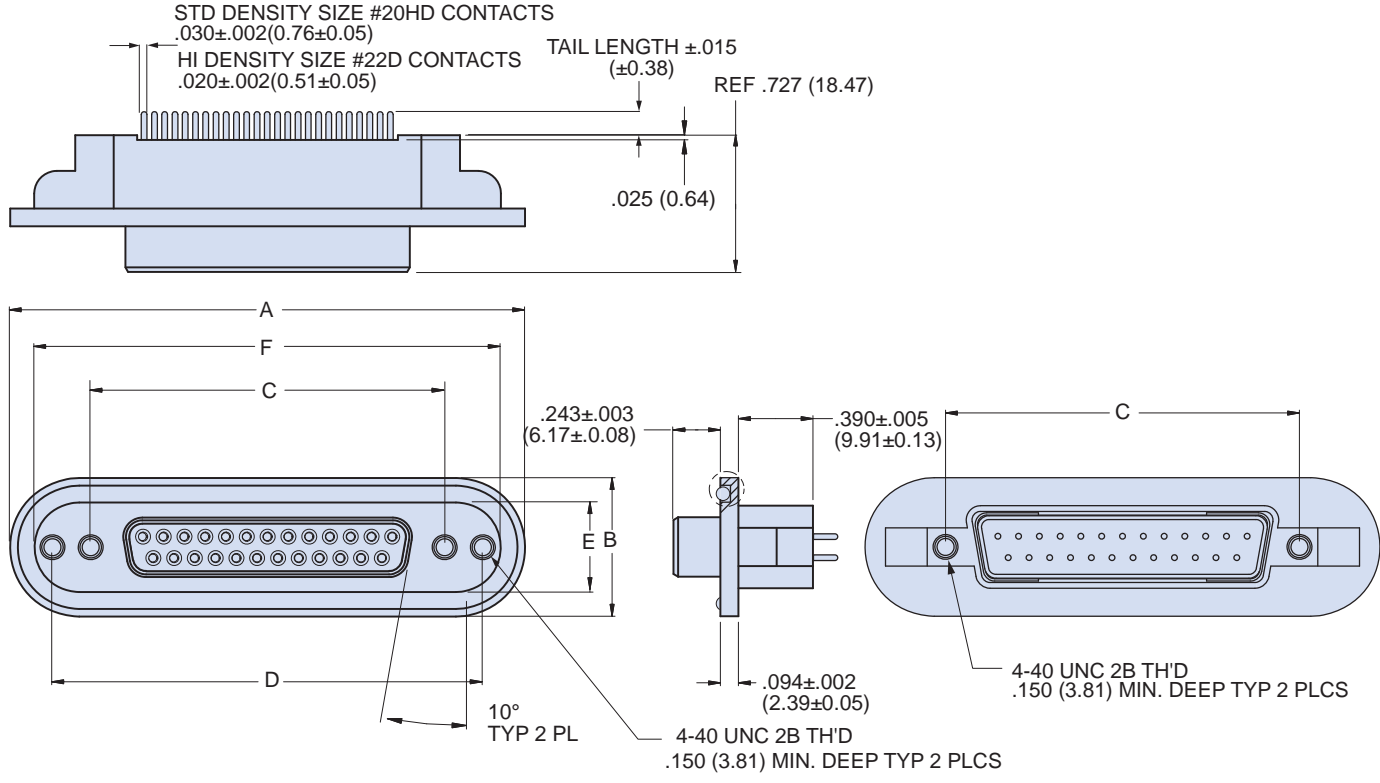

Shell Size	A		B		C Basic		D Basic		E		F	
	in ±.015	mm ± 0.38	in ±.015	mm ± 0.38	in.	mm	in	mm	in ±.005	mm ± 0.13	in ±.015	mm ± 0.38
1	1.865	47.37	.725	18.42	.984	24.99	1.424	36.17	.469	11.91	1.609	40.87
2	2.200	55.88	.725	18.42	1.312	33.32	1.752	44.50	.469	11.91	1.944	49.38
3	2.736	69.49	.725	18.42	1.852	47.04	2.292	58.22	.469	11.91	2.480	62.99
4	3.385	85.98	.725	18.42	2.500	63.50	2.940	74.68	.469	11.91	3.129	79.48
5	3.289	83.54	.837	21.26	2.406	61.11	2.846	72.29	.581	14.76	3.033	77.04
6	3.383	85.93	.899	22.83	2.500	63.50	2.940	74.68	.643	16.33	3.127	79.43

### 280-023S PANEL CUTOUTS

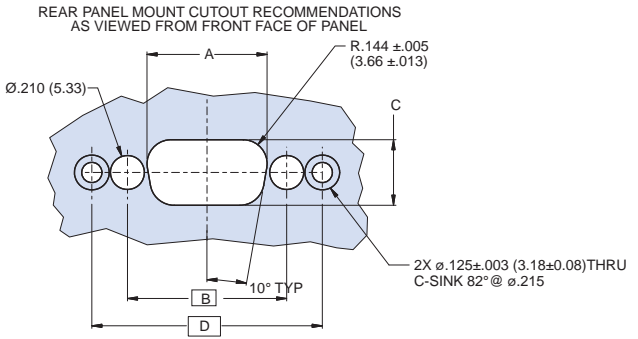

Shell Size	A		B Basic		C		D Basic	
	in +.005 -.000	mm +0.13 -0.00	in	mm	in. +.005 -.000	mm +0.13 -0.00	in	mm
1	.746	18.95	.984	24.99	.409	10.39	1.424	36.17
2	1.074	27.28	1.312	33.32	.409	10.39	1.752	44.50
3	1.614	41.00	1.852	47.04	.409	10.39	2.292	58.22
4	2.262	57.45	2.500	63.50	.409	10.39	2.940	74.68
5	2.159	54.84	2.406	61.11	.521	13.23	2.846	72.29
6	2.292	58.22	2.500	63.50	.583	14.81	2.940	74.68

Dimensions in inches (millimeters) and are subject to change without notice.

# 280-027S

## Series 28 HiPer-D Free-Standing Socket Connector with Straight PC Tail Contacts



### Free-standing PCB Socket Connectors

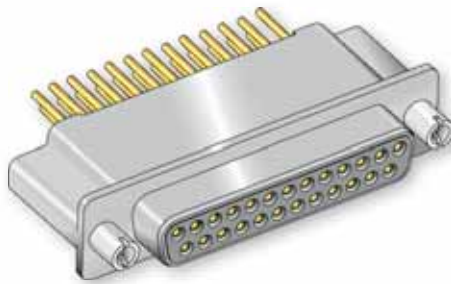

Free-standing HiPer-D socket connectors feature non-removable size #20 or #22D straight PC tail contacts. Intermateable with standard M24308-type D-Subminiature connectors, the HiPer-D features a rugged machined shell, waterproof sealing and optional ground springs for improved resistance to electromagnetic interference. Threaded holes on the rear of the connector allow attachment to circuit board. Contacts are potted with epoxy. Aluminum shell. Glass-reinforced thermoset epoxy insulators. 1000 VAC, 5 Amps (#22D) or 7.5 Amps (#20).

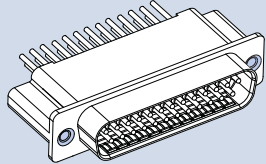
HOW TO ORDER				
Sample Part Number				
280-027S	2H26	ME	P	A
Part Number	Shell Size - Insert Arr.	Shell Material/Finish	Hardware Option	PC Tail Length
<b>280-027S</b> HiPer-D Free-standing Socket Connector With Straight PC Tails	Standard Density #20 Contacts  Layout      Contact Quantity <b>1S9</b> 9 <b>2S15</b> 15 <b>3S25</b> 25 <b>4S37</b> 37 <b>5S50</b> 50	<b>ME</b> Aluminum with Electroless Nickel Finish <i>general purpose applications, excellent conductivity</i>  <b>MT</b> Aluminum with Nickel-PTFE Finish <i>1000 Hour Grey™ maximum corrosion protection, durability, and excellent conductivity (non-reflective grey)</i>	 <b>N</b> #4-40 Female Threads in Mounting Holes <i>Choose this option for rear panel mounting and order jackpost kit 289-016 separately.</i>	<b>A</b> .125 inches (3.18 mm)
	High Density #22D Contacts  Layout      Contact Quantity <b>1H15</b> 15 <b>2H26</b> 26 <b>3H44</b> 44 <b>4H62</b> 62 <b>5H78</b> 78 <b>6H104</b> 104			<b>JF</b> Aluminum with Cadmium, Yellow Chromate <i>for severe environments, excellent conductivity</i>

SPECIFICATIONS	
Current Rating	#22D 5 AMPS, #20 7.5 AMPS
Test Voltage	1000 VAC RMS
Insulation Resistance	5000 megohms minimum
Operating Temperature	-65° C. to +200° C.
Shock	300 g.
Vibration, Random	43.92 g.

MATERIALS AND FINISHES	
Shell	6061 Aluminum
Contacts	Copper alloy, 50 microinches gold plated
Insulators	Thermoset epoxy
Potting Compound	Epoxy
Hardware	300 series stainless steel

Dimensions in inches (millimeters) and are subject to change without notice.





# 280-027S

## Series 28 HiPer-D Free-Standing Socket Connector with Straight PC Tail Contacts

### HIPER-D CONTACT ARRANGEMENTS: STANDARD DENSITY, #20 CONTACTS

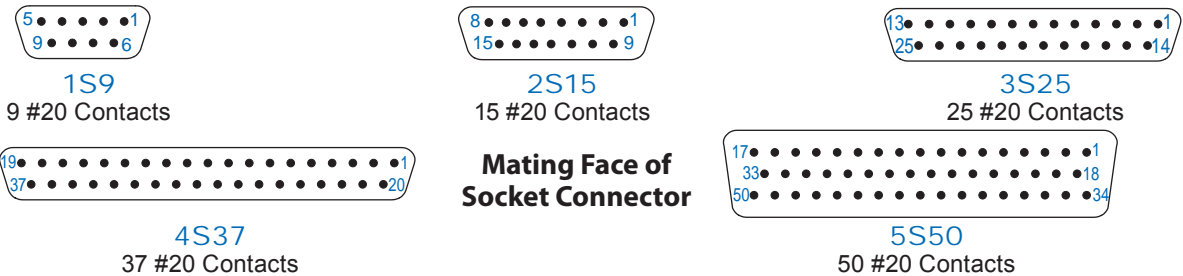

### HIPER-D CONTACT ARRANGEMENTS: HIGH DENSITY, #22D CONTACTS

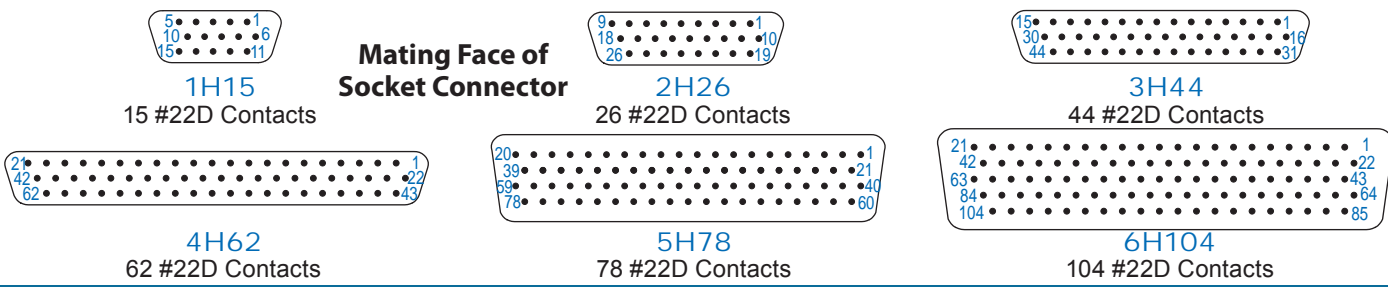

### 280-027S DIMENSIONS

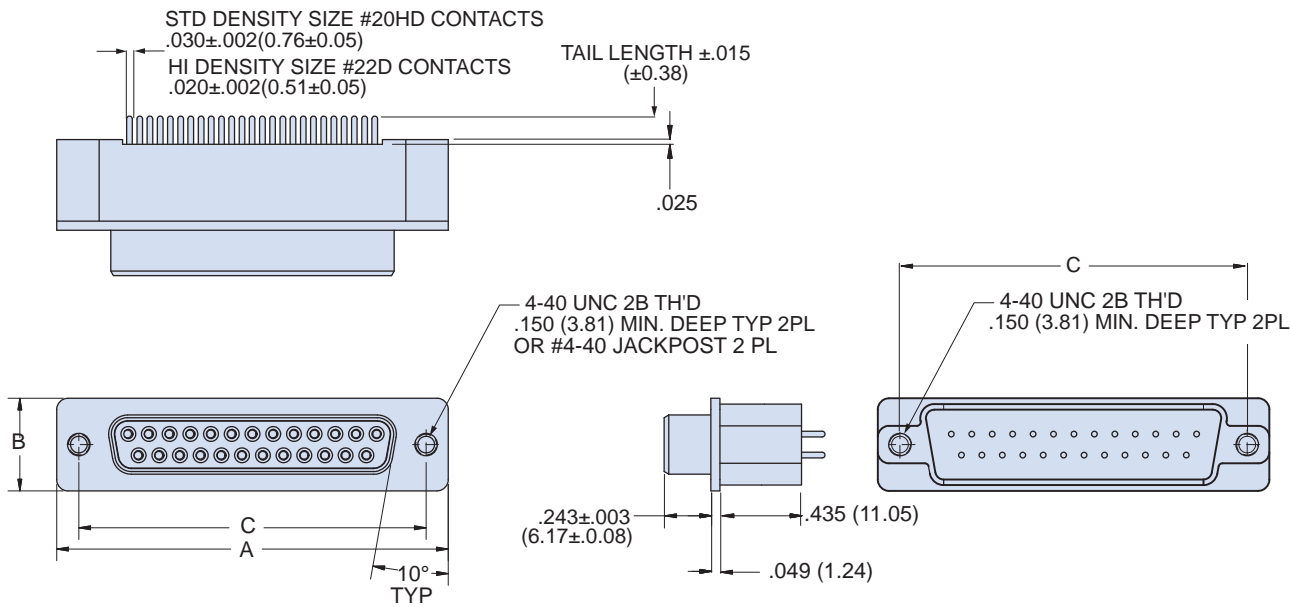

Shell Size	A		B		C Basic	
	in ± .015	mm ± 0.38	in ± .015	mm ± 0.38	in.	mm
1	1.213	30.81	.494	12.55	.984	24.99
2	1.541	39.14	.494	12.55	1.312	33.32
3	2.088	53.04	.494	12.55	1.852	47.04
4	2.729	69.32	.494	12.55	2.500	63.50
5	2.635	66.93	.605	15.37	2.406	61.11
6	2.729	69.32	.668	16.97	2.500	63.50

Dimensions in inches (millimeters) and are subject to change without notice.

CAGE Code 06324

Printed in U.S.A.

**GLENAIR, INC. • 1211 AIR WAY • GLENDALE, CA 91201-2497 • 818-247-6000 • FAX 818-500-9912**

280-023S and 280-027S  
 Series 28 HiPer-D Free-Standing Socket Connector  
 with Straight PC Tail Contacts



280-023S AND 280-027S PRINTED CIRCUIT BOARD PATTERNS

Component Mounting Side of PCB

1S9  
9 #20

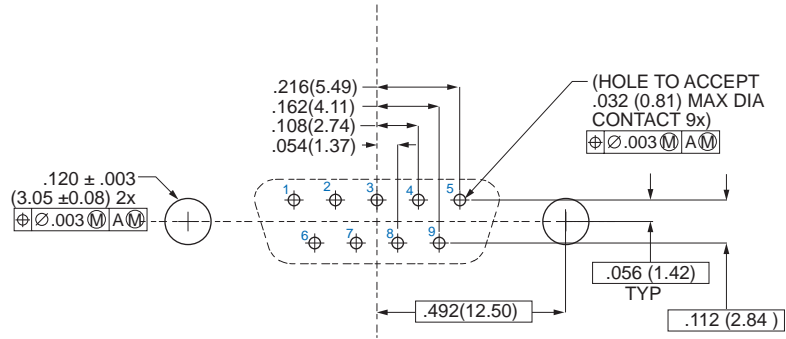

2S15  
15 #20

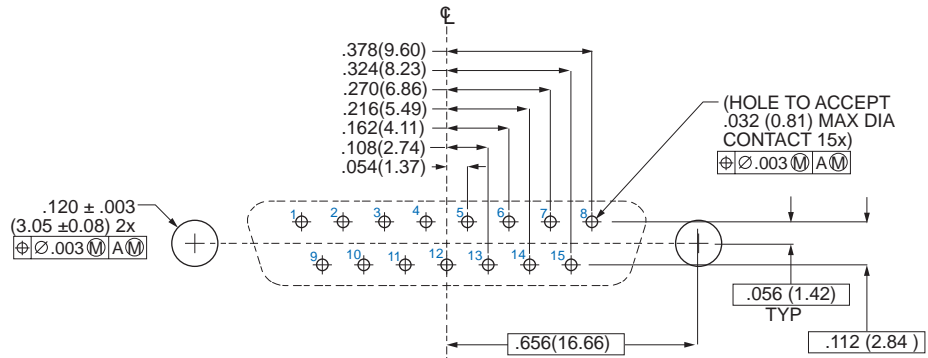

3S25  
25 #20

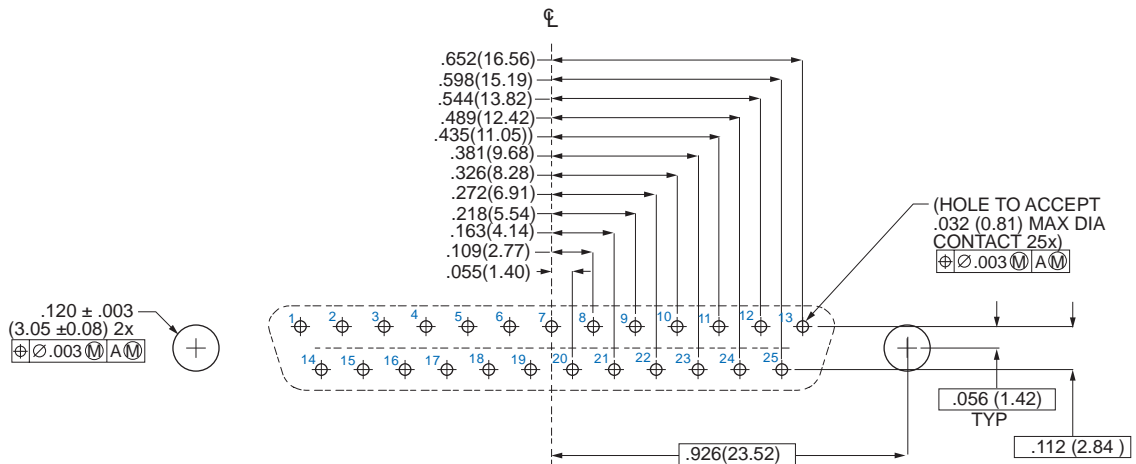

Dimensions in inches (millimeters) and are subject to change without notice.



280-023S and 280-027S  
Series 28 HiPer-D Free-Standing Socket Connector  
with Straight PC Tail Contacts

280-023S AND 280-027S PRINTED CIRCUIT BOARD PATTERNS

Component Mounting Side of PCB

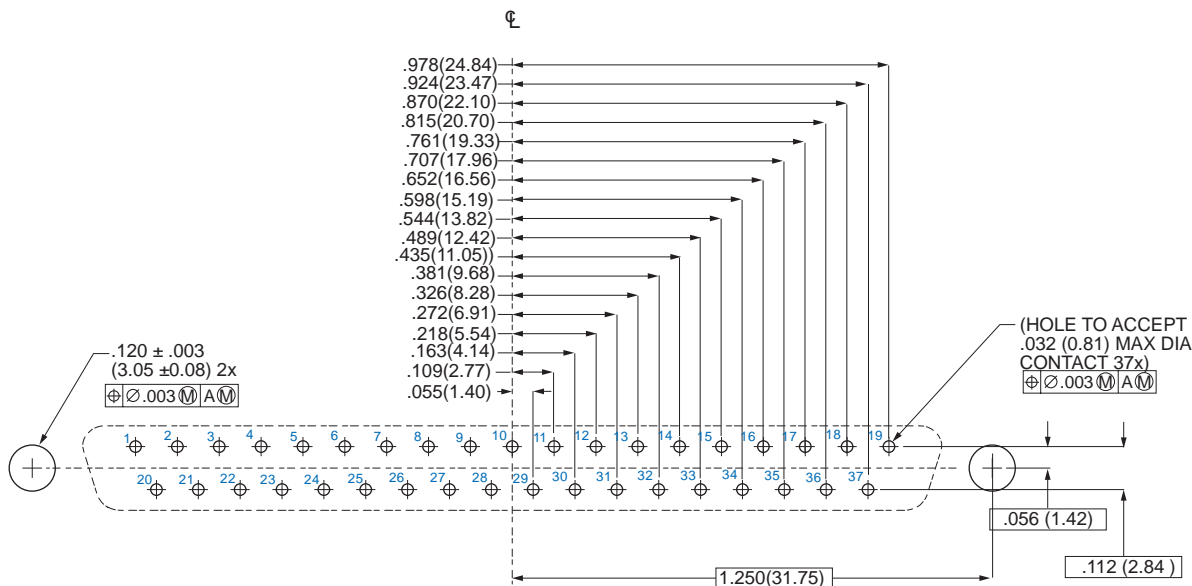

**4S37**  
37 #20

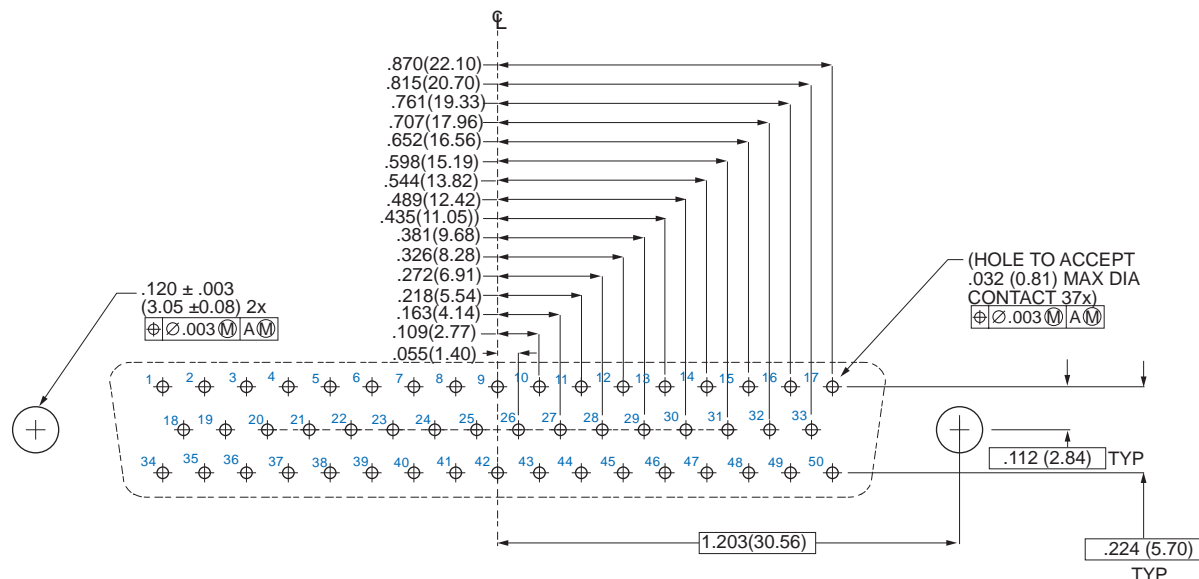

**5S50**  
50 #20

Dimensions in inches (millimeters) and are subject to change without notice.

# 280-023S and 280-027S Series 28 HiPer-D Free-Standing Socket Connector with Straight PC Tail Contacts



## 280-023S AND 280-027S PRINTED CIRCUIT BOARD PATTERNS

### Component Mounting Side of PCB

**1H15**  
15 #22D

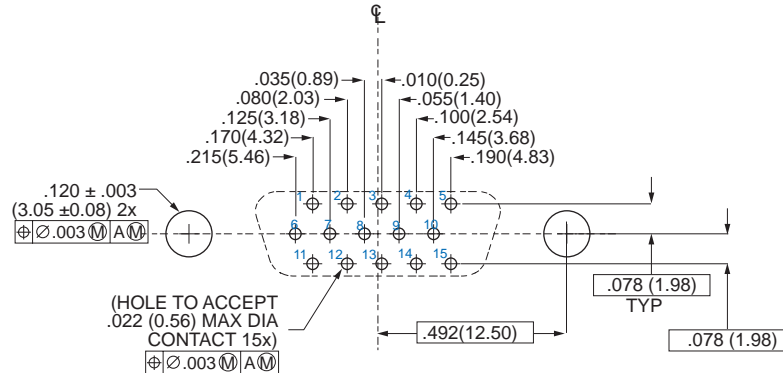

**2H26**  
26 #22D

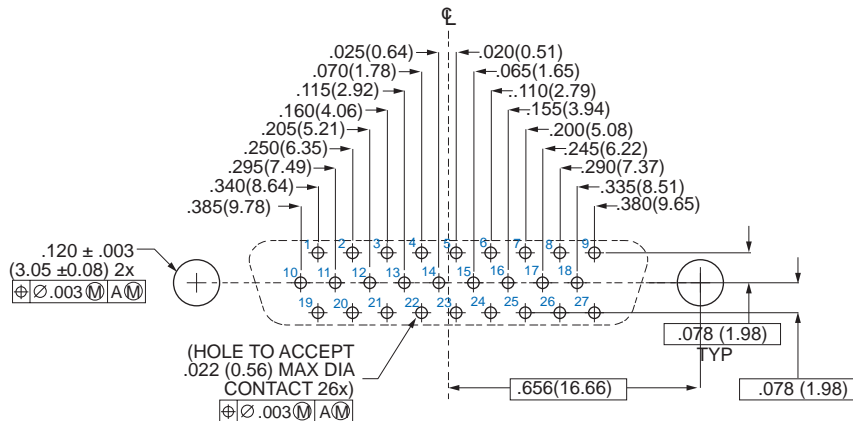

**3H44**  
44 #22D

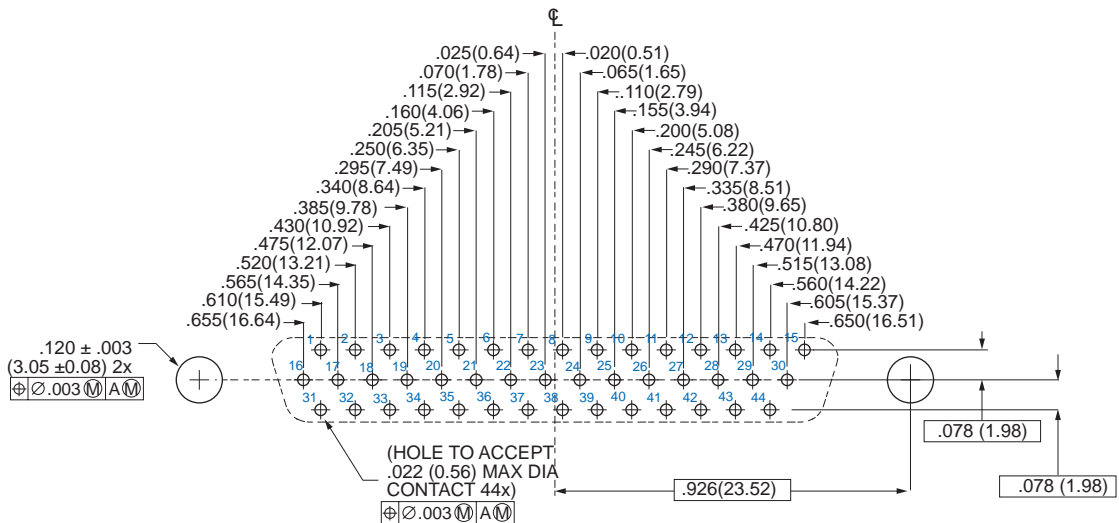

Dimensions in inches (millimeters) and are subject to change without notice.





**280-023S and 280-027S**  
**Series 28 HiPer-D Free-Standing Socket Connector**  
**with Straight PC Tail Contacts**



**280-023S AND 280-027S PRINTED CIRCUIT BOARD PATTERNS**

**Component Mounting Side of PCB**

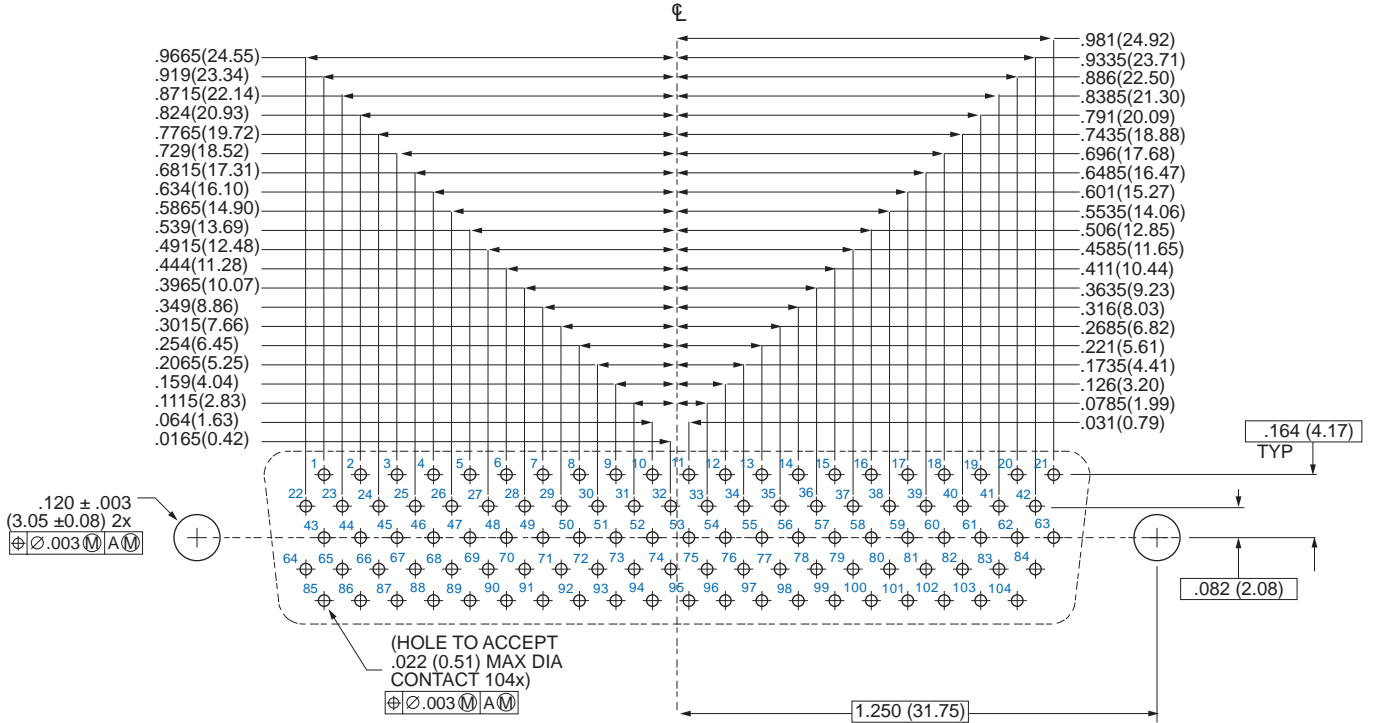

**6H104**  
**104 #22D**

Dimensions in inches (millimeters) and are subject to change without notice.



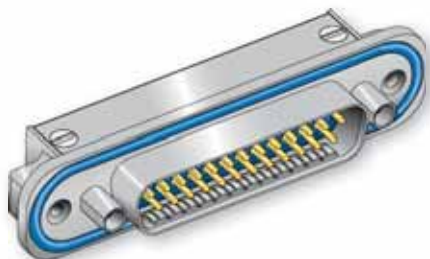

## 280-024P Series 28 HiPer-D Panel Mount Right Angle PCB Headers

### HiPer-D Panel Mount Pin Connectors with Right Angle PC Tails

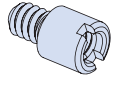

Rear panel mount HiPer-D pin connectors feature rugged one-piece machined aluminum shell and stainless steel shroud for improved EMI protection. Contacts are non-removable size #20 or #22D straight PC tail contacts. Intermateable with standard M24308-type D-Subminiature connectors, the HiPer-D features environmental sealing and optional ground springs for improved resistance to electromagnetic interference. #4-40 threaded mounting holes simplify panel attachment. Threaded holes on the bottom of connector allow attachment to circuit board. Contacts are potted with epoxy. Glass-reinforced thermoset epoxy insulators, fluorosilicone face seal. 1000 VAC, 5 Amps (#22D) or 7.5 Amps (#20).

#### HOW TO ORDER

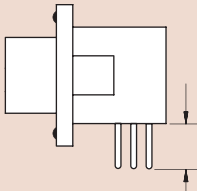
Sample Part Number									
280-024P	4S37	ME	G	B	A				
Part Number	Shell Size - Insert Arr.	Shell Material/ Finish	EMI Spring	Hardware Option	PC Tail Length				
<b>280-024P</b> HiPer-D Panel Mount Pin Connector With Right Angle PC Tails	Standard Density #20 Contacts	<b>ME</b> Aluminum with Electroless Nickel Finish <i>general purpose applications, excellent conductivity</i>	<b>G</b> EMI Spring	 <b>N</b> #8-32 Threaded Hole	<b>A</b> .125 inches (3.18 mm)				
	Layout <b>Contact Quantity</b> <b>1S9</b> 9 <b>2S15</b> 15 <b>3S25</b> 25 <b>4S37</b> 37 <b>5S50</b> 50					<b>MT</b> Aluminum with Nickel-PTFE Finish <i>1000 Hour Grey™ maximum corrosion protection, durability, and excellent conductivity (non-reflective grey)</i>	<b>N</b> No Spring	 <b>P</b> #4-40 Female Jackpost	<b>B</b> .250 inches (6.35 mm)
	High Density #22D Contacts		<b>JF</b> Aluminum with Cadmium, Yellow Chromate <i>for severe environments, excellent conductivity</i>	 <b>G</b> Male Guide Pin					
	Layout <b>Contact Quantity</b> <b>1H15</b> 15 <b>2H26</b> 26 <b>3H44</b> 44 <b>4H62</b> 62 <b>5H78</b> 78 <b>6H104</b> 104								

#### SPECIFICATIONS

Current Rating	#22D 5 AMPS, #20 7.5 AMPS
Test Voltage	1000 VAC RMS
Insulation Resistance	5000 megohms minimum
Operating Temperature	-65° C. to +200° C.
Ingress Protection	IP 67
Shock	300 g.
Vibration, Random	43.92 g.

#### MATERIALS AND FINISHES

Shell	Aluminum alloy
Contacts	Copper alloy, 50 microinches gold plated
Insulators	Thermoset epoxy, glass-filled
Potting Compound	Epoxy
Face Seal	Fluorosilicone rubber
Hardware	300 series stainless steel

Dimensions in inches (millimeters) and are subject to change without notice.

280-024P  
Series 28 HiPer-D  
Panel Mount Right Angle PCB Headers



HIPER-D CONTACT ARRANGEMENTS: STANDARD DENSITY, #20 CONTACTS

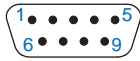

1S9  
9 #20 Contacts

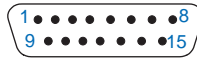

2S15  
15 #20 Contacts

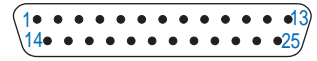

3S25  
25 #20 Contacts

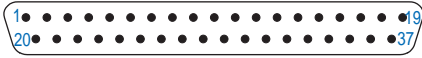

4S37  
37 #20 Contacts

Mating Face of Pin  
Connector

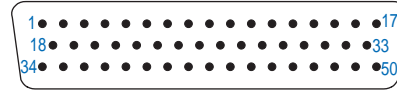

5S50  
50 #20 Contacts

HIPER-D CONTACT ARRANGEMENTS: HIGH DENSITY, #22D CONTACTS

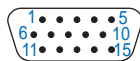

1H15  
15 #22D Contacts

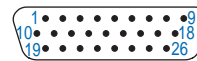

2H26  
26 #22D Contacts

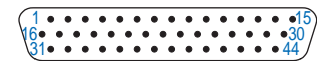

3H44  
44 #22D Contacts

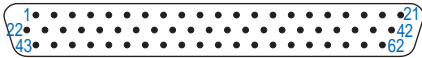

4H62  
62 #22D Contacts

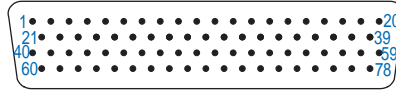

5H78  
78 #22D Contacts

Mating Face of Pin  
Connector

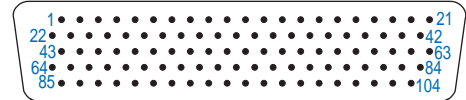

6H104  
104 #22D Contacts

HARDWARE OPTION

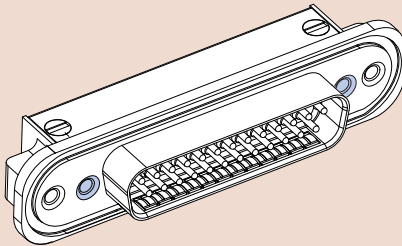

**N**  
No Mating Hardware

Connector is supplied without mating hardware. Hardware attachment holes are #8-32 UNC 2B, .150 min. deep.

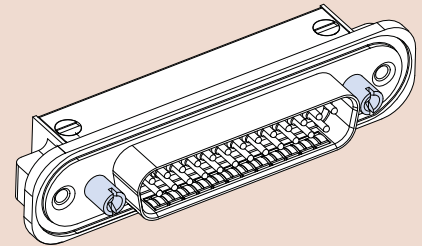

**P**  
Jackposts

Connector is supplied with non-removable stainless steel jackposts. #4-40 UNC 2B thread. Stainless steel.

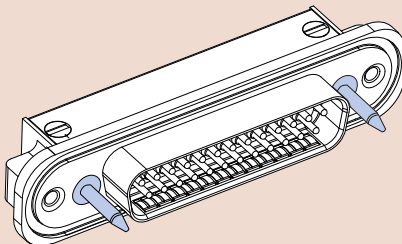

**G**  
Guide Pins

Connector is supplied with stainless steel non-removable guide pins. Mates with type "B" guide bushings on mating connector.

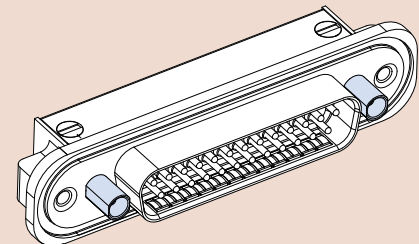

**B**  
Female Guide Bushing

Connector is supplied with stainless steel non-removable bushings. Mates with type "G" guide pins on mating connector.

Dimensions in inches (millimeters) and are subject to change without notice.



# 280-024P Series 28 HiPer-D Panel Mount Right Angle PCB Headers

## 280-024P DIMENSIONS

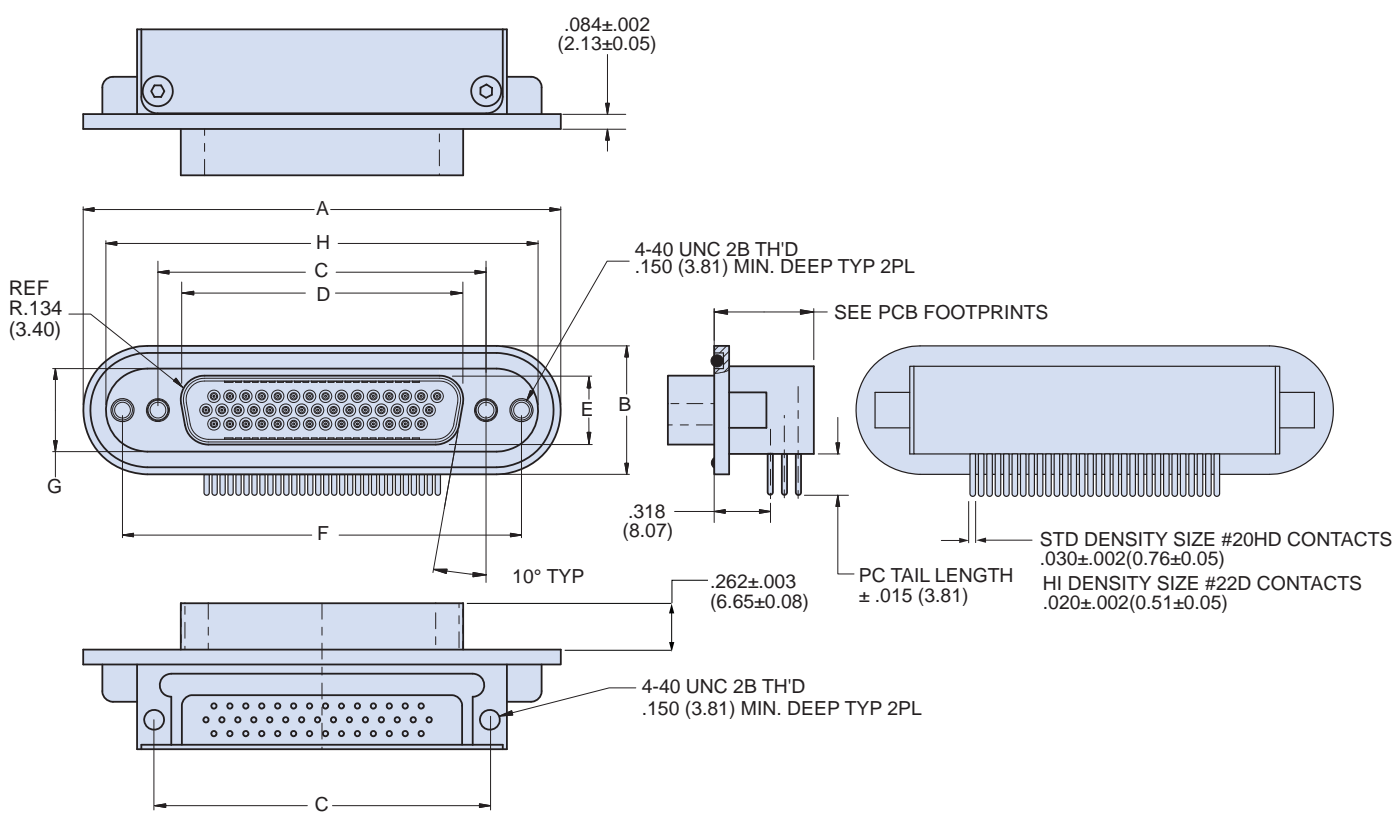

Shell Size	A		B		C Basic		D		E		F Basic		G		H	
	in	mm	in	mm	in.	mm	in	mm	in	mm	in	mm	in	mm	in	mm
1	1.865 ± .015	47.37 ± 0.38	.725 ± .015	18.42 ± 0.38	.984 ± .015	24.99 ± 0.38	.726 ± .005	18.44 ± 0.13	.389 ± .005	9.88 ± 0.13	1.424 ± .015	36.17 ± 0.38	.469 ± .015	11.91 ± 0.38	1.609 ± .015	40.87 ± 0.38
2	2.200 ± .015	55.88 ± 0.38	.725 ± .015	18.42 ± 0.38	1.312 ± .015	33.32 ± 0.38	1.054 ± .005	26.77 ± 0.13	.389 ± .005	9.88 ± 0.13	1.752 ± .015	44.50 ± 0.38	.469 ± .015	11.91 ± 0.38	1.944 ± .015	49.38 ± 0.38
3	2.736 ± .015	69.49 ± 0.38	.725 ± .015	18.42 ± 0.38	1.852 ± .015	47.04 ± 0.38	1.594 ± .005	40.49 ± 0.13	.389 ± .005	9.88 ± 0.13	2.292 ± .015	58.22 ± 0.38	.469 ± .015	11.91 ± 0.38	2.480 ± .015	62.99 ± 0.38
4	3.385 ± .015	85.98 ± 0.38	.725 ± .015	18.42 ± 0.38	2.500 ± .015	63.50 ± 0.38	2.242 ± .005	56.95 ± 0.13	.389 ± .005	9.88 ± 0.13	2.940 ± .015	74.68 ± 0.38	.469 ± .015	11.91 ± 0.38	3.129 ± .015	79.48 ± 0.38
5	3.289 ± .015	83.54 ± 0.38	.837 ± .015	21.26 ± 0.38	2.406 ± .015	61.11 ± 0.38	2.139 ± .005	54.33 ± 0.13	.501 ± .005	12.73 ± 0.13	2.846 ± .015	72.29 ± 0.38	.581 ± .015	14.76 ± 0.38	3.033 ± .015	77.04 ± 0.38
6	3.383 ± .015	85.93 ± 0.38	.899 ± .015	22.83 ± 0.38	2.500 ± .015	63.50 ± 0.38	2.272 ± .005	57.71 ± 0.13	.563 ± .005	14.30 ± 0.13	2.940 ± .015	74.68 ± 0.38	.643 ± .015	16.33 ± 0.38	3.127 ± .015	79.43 ± 0.38

## 280-024P PANEL CUTOUTS

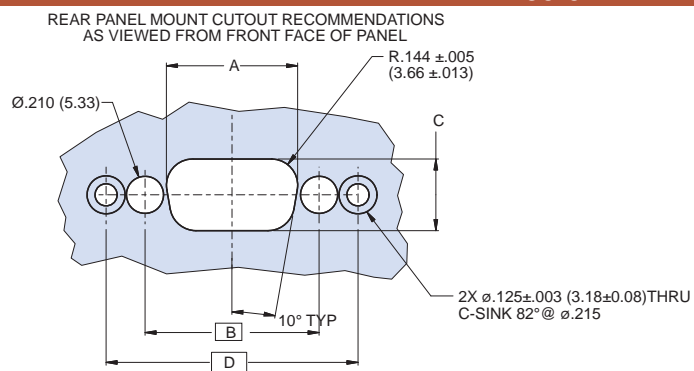

Shell Size	A		B Basic		C		D Basic	
	in	mm	in	mm	in.	mm	in	mm
1	.746 ± .005	18.95 ± 0.13	.984 ± .005	24.99 ± 0.13	.409 ± .005	10.39 ± 0.13	1.424 ± .005	36.17 ± 0.13
2	1.074 ± .005	27.28 ± 0.13	1.312 ± .005	33.32 ± 0.13	.409 ± .005	10.39 ± 0.13	1.752 ± .005	44.50 ± 0.13
3	1.614 ± .005	41.00 ± 0.13	1.852 ± .005	47.04 ± 0.13	.409 ± .005	10.39 ± 0.13	2.292 ± .005	58.22 ± 0.13
4	2.262 ± .005	57.45 ± 0.13	2.500 ± .005	63.50 ± 0.13	.409 ± .005	10.39 ± 0.13	2.940 ± .005	74.68 ± 0.13
5	2.159 ± .005	54.84 ± 0.13	2.406 ± .005	61.11 ± 0.13	.521 ± .005	13.23 ± 0.13	2.846 ± .005	72.29 ± 0.13
6	2.292 ± .005	58.22 ± 0.13	2.500 ± .005	63.50 ± 0.13	.583 ± .005	14.81 ± 0.13	2.940 ± .005	74.68 ± 0.13

Dimensions in inches (millimeters) and are subject to change without notice.

**280-028P**  
**Series 28 HiPer-D**  
**Free-Standing Right Angle PCB Headers**



Right Angle PCB

**Free-Standing Right Angle PCB Pin Connectors**

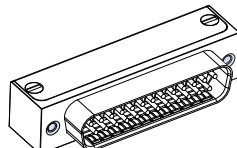

Free-standing HiPer-D pin connectors feature rugged machined aluminum shell and stainless steel cover for improved EMI protection. Contacts are non-removable size #20 or #22D. Intermateable with standard M24308-type D-Subminiature connectors, the HiPer-D features a resilient face seal for environmental protection and optional ground springs for improved resistance to electromagnetic interference. Threaded holes on the bottom of the connector allow attachment to circuit board. Contacts are potted with epoxy. Glass-reinforced thermoset epoxy insulators, fluorosilicone face seal. 1000 VAC, 5 Amps (#22D) or 7.5 Amps (#20).

HOW TO ORDER					
Sample Part Number					
280-028P	3S25	ME	G	P	B
Part Number	Shell Size - Insert Arr.	Shell Material/Finish	EMI Spring	Hardware Option	PC Tail Length
<b>280-028P</b> HiPer-D Free-standing Pin Connector With Right Angle PC Tails	Standard Density #20 Contacts  Layout <b>Contact Quantity</b> <b>1S9</b> 9 <b>2S15</b> 15 <b>3S25</b> 25 <b>4S37</b> 37 <b>5S50</b> 50	<b>ME</b> Aluminum with Electroless Nickel Finish <i>general purpose applications, excellent conductivity</i>  <b>MT</b> Aluminum with Nickel-PTFE Finish <i>1000 Hour Grey™ maximum corrosion protection, durability, and excellent conductivity (non-reflective grey)</i>	<b>G</b> EMI Spring  <b>N</b> No Spring	 <b>N</b> #4-40 Female Threads in Mounting Holes <i>Choose this option for rear panel mounting and order jackpost kit 289-016 separately.</i>	<b>A</b> .125 inches (3.18mm)  <b>B</b> .250 inches (6.35mm)
	High Density #22D Contacts  Layout <b>Contact Quantity</b> <b>1H15</b> 15 <b>2H26</b> 26 <b>3H44</b> 44 <b>4H62</b> 62 <b>5H78</b> 78 <b>6H104</b> 104				

SPECIFICATIONS	
Current Rating	#22D 5 AMPS, #20 7.5 AMPS
Test Voltage	1000 VAC RMS
Insulation Resistance	5000 megohms minimum
Operating Temperature	-65° C. to +200° C.
Ingress Protection	IP 67
Shock	300 g.
Vibration, Random	43.92 g.

MATERIALS AND FINISHES	
Shell	Aluminum alloy
Contacts	Copper alloy, 50 microinches gold plated
Insulators	Thermoset epoxy, glass-filled
Potting Compound	Epoxy
Face Seal	Fluorosilicone rubber
Hardware	300 series stainless steel

Dimensions in inches (millimeters) and are subject to change without notice.





# 280-028P Series 28 HiPer-D Free-Standing Right Angle PCB Headers

## HIPER-D CONTACT ARRANGEMENTS (MATING FACE OF PIN CONNECTOR)

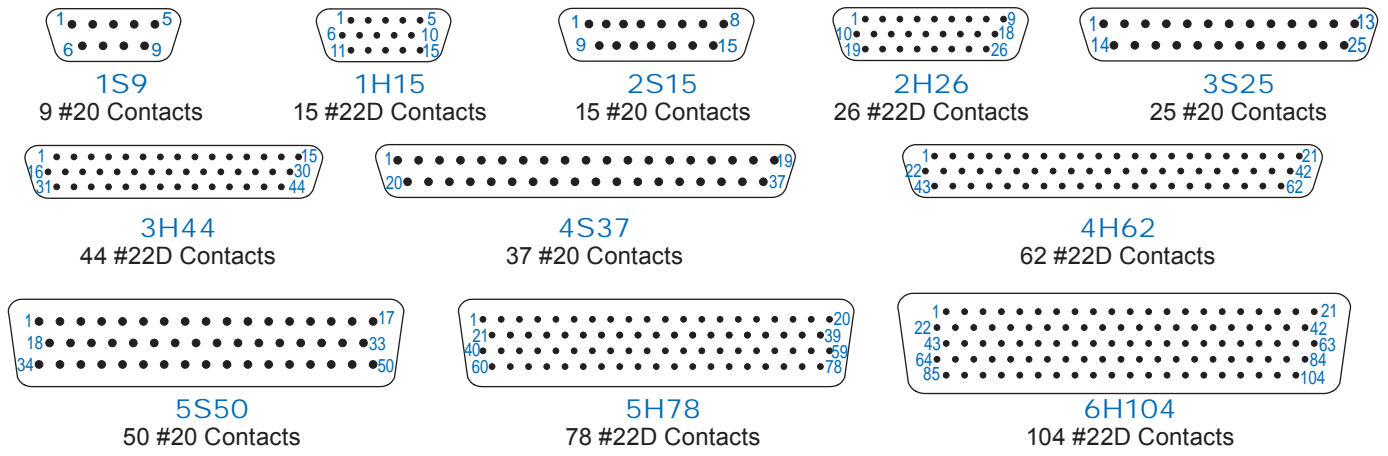

## 280-028P DIMENSIONS

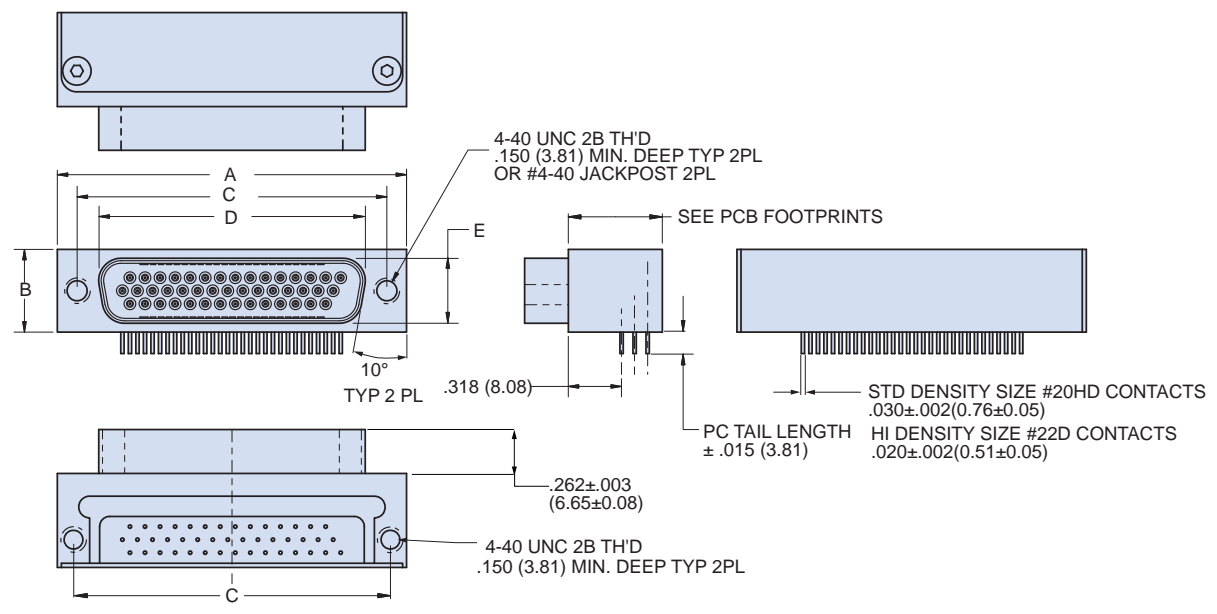

Shell Size	A		B		C Basic		D		E	
	in ± .015	mm ± 0.38	in ± .015	mm ± 0.38	in.	mm	in ± .005	mm ± 0.13	in ± .005	mm ± 0.13
1	1.213	30.81	.494	12.55	.984	24.99	.726	18.44	.389	9.88
2	1.541	39.14	.494	12.55	1.312	33.32	1.054	26.77	.389	9.88
3	2.088	53.04	.494	12.55	1.852	47.04	1.594	40.49	.389	9.88
4	2.729	69.32	.494	12.55	2.500	63.50	2.242	56.95	.389	9.88
5	2.635	66.93	.605	15.37	2.406	61.11	2.139	54.33	.501	12.73
6	2.729	69.32	.668	16.97	2.500	63.50	2.272	57.71	.563	14.30

Dimensions in inches (millimeters) and are subject to change without notice.

280-024P and 280-028P  
Printed Circuit Board Mounting Patterns  
HiPer-D Right Angle Headers



Right Angle  
PCB

280-024P AND 280-028P PRINTED CIRCUIT BOARD PATTERNS

Component Mounting Side of PCB

1S9  
9 #20

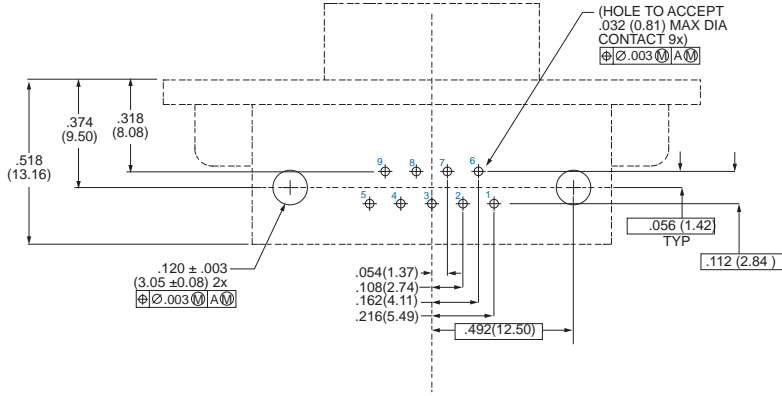

2S15  
15 #20

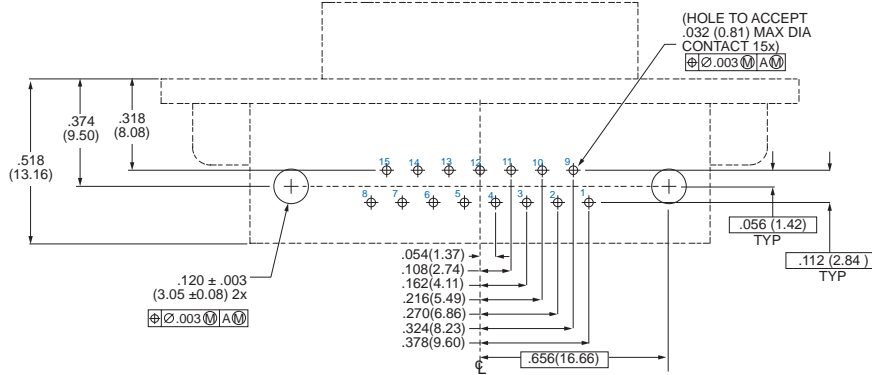

3S25  
25 #20

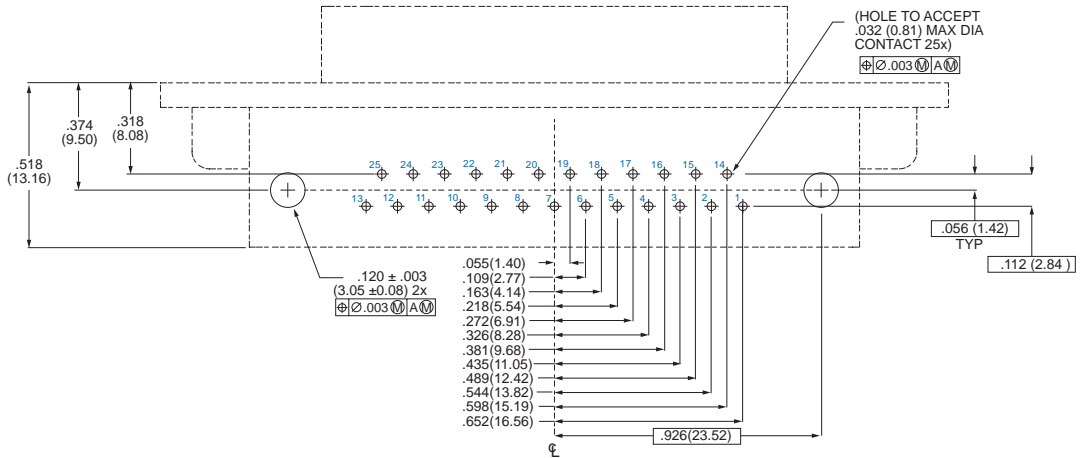

Dimensions in inches (millimeters) and are subject to change without notice.

G



# 280-024P and 280-028P Printed Circuit Board Mounting Patterns HiPer-D Right Angle Headers

## 280-024P AND 280-028P PRINTED CIRCUIT BOARD PATTERNS Component Mounting Side of PCB

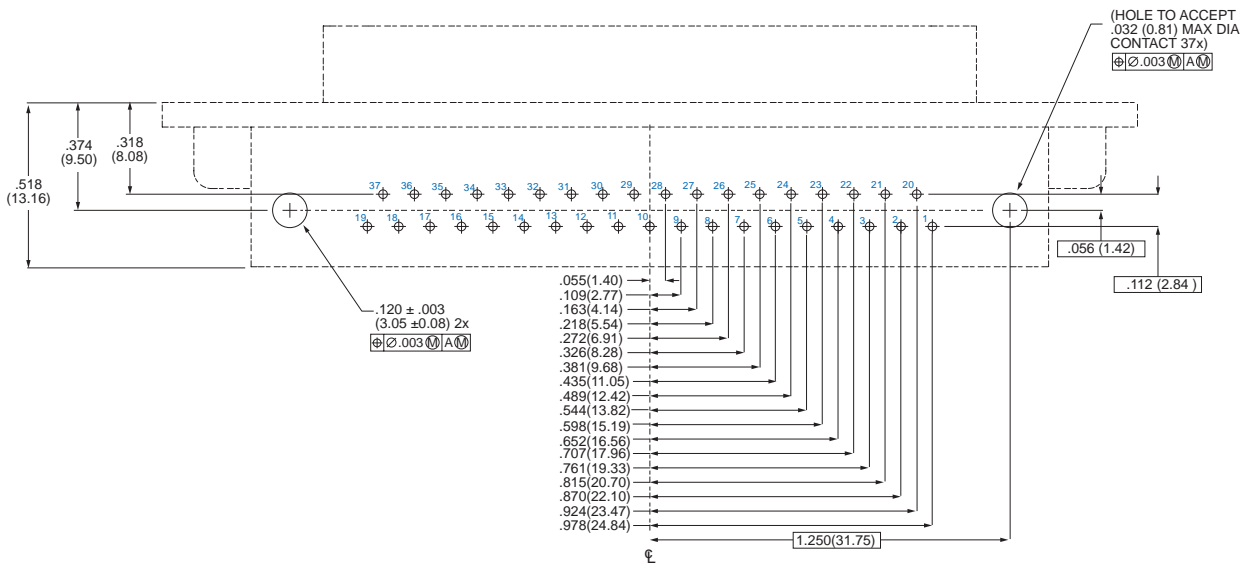

**4S37**  
37 #20

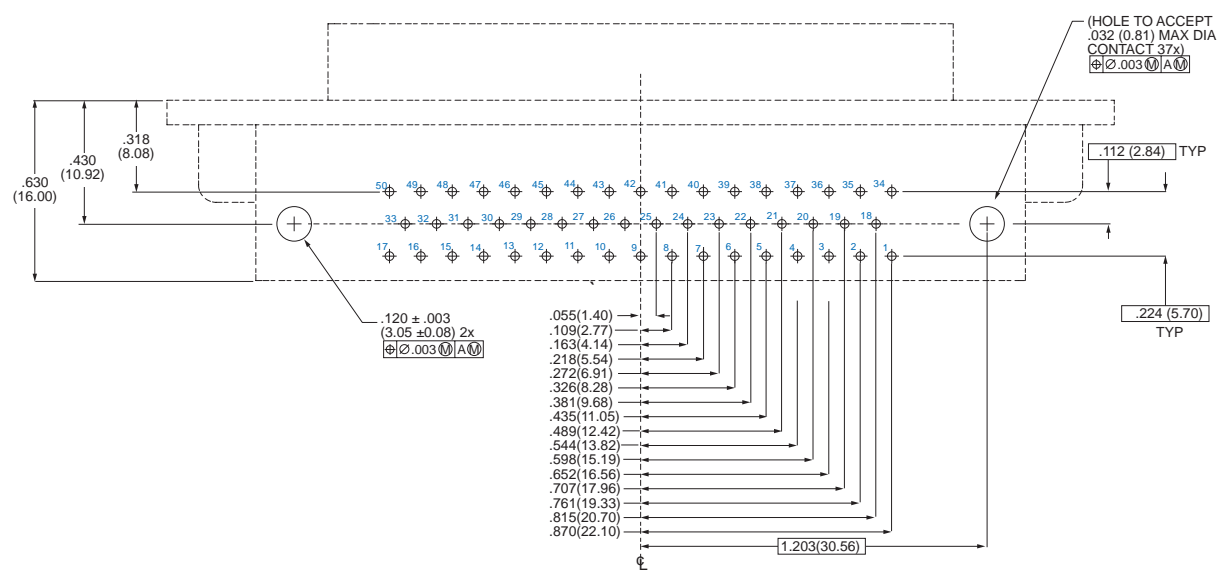

**5S50**  
50 #20

Dimensions in inches (millimeters) and are subject to change without notice.

280-024P and 280-028P  
Printed Circuit Board Mounting Patterns  
HiPer-D Right Angle Headers



Right Angle  
PCB

280-024P AND 280-028P PRINTED CIRCUIT BOARD PATTERNS

Component Mounting Side of PCB

1H15  
15 #22D

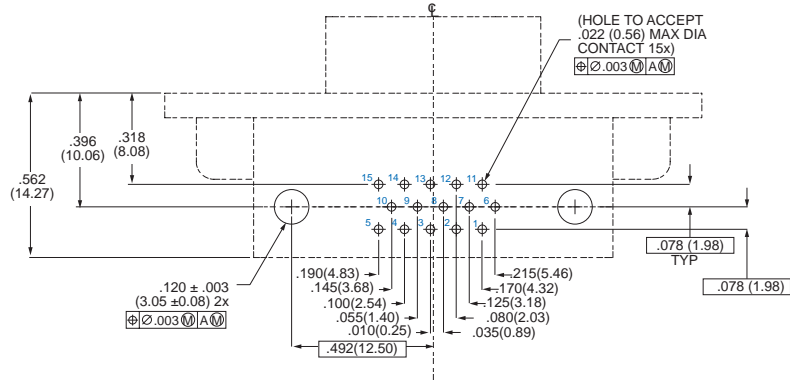

2H26  
26 #22D

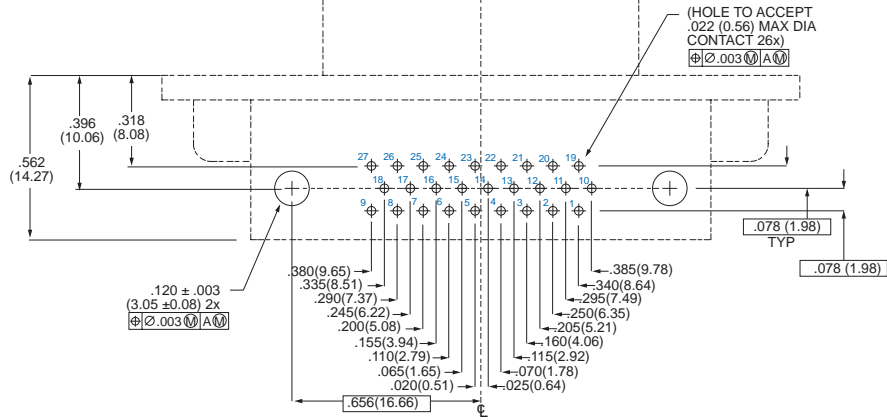

3H44  
44 #22D

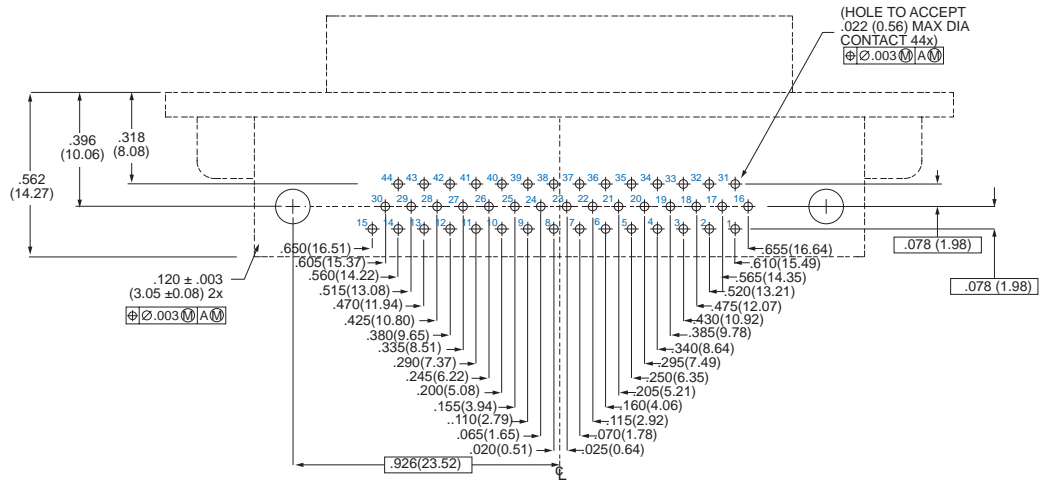

Dimensions in inches (millimeters) and are subject to change without notice.





# 280-024P and 280-028P Printed Circuit Board Mounting Patterns HiPer-D Right Angle Headers

## 280-024P AND 280-028P PRINTED CIRCUIT BOARD PATTERNS Component Mounting Side of PCB

**4H62**  
62 #22D

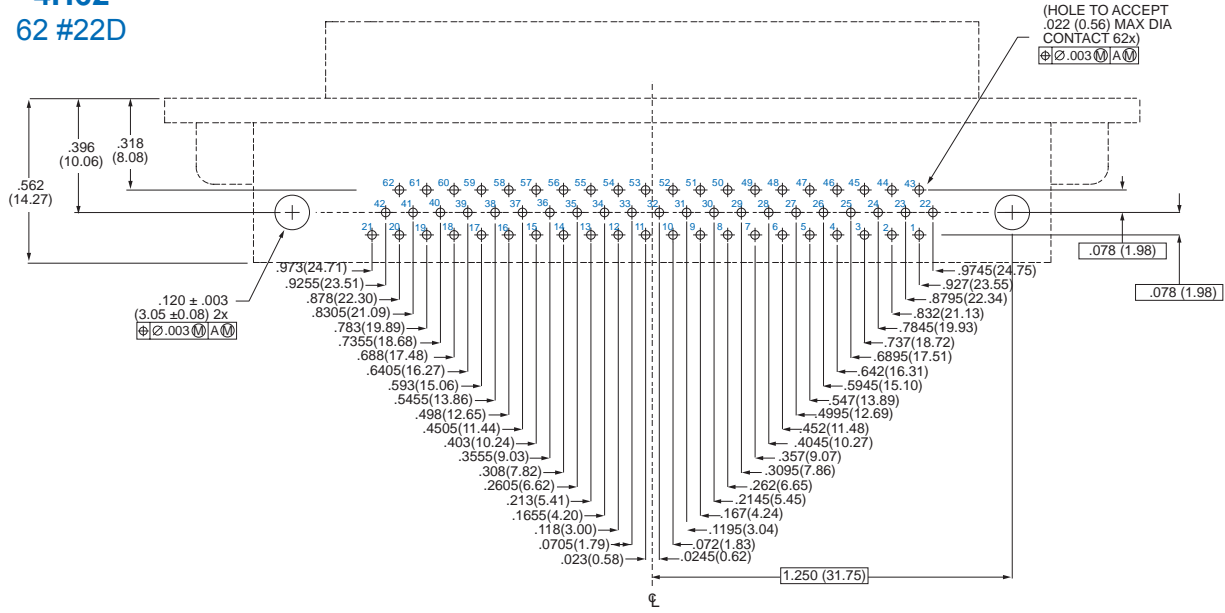

**5H78**  
78 #22D

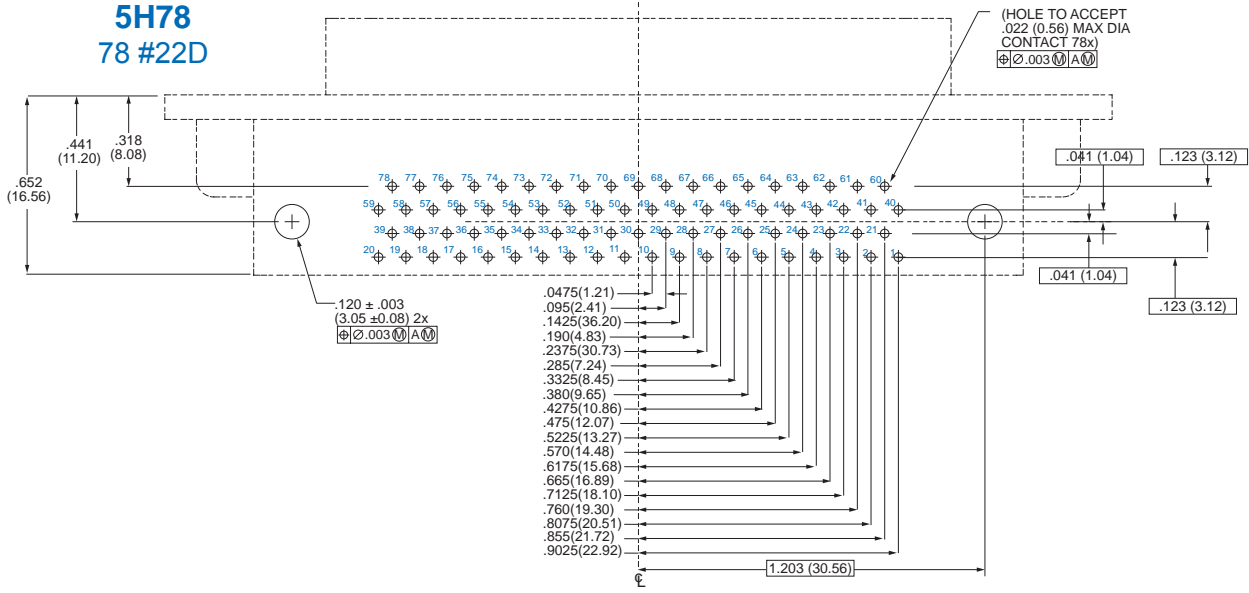

Dimensions in inches (millimeters) and are subject to change without notice.



280-024P and 280-028P  
Printed Circuit Board Mounting Patterns  
HiPer-D Right Angle Headers



Right Angle  
PCB

280-024P AND 280-028P PRINTED CIRCUIT BOARD PATTERNS

Component Mounting Side of PCB

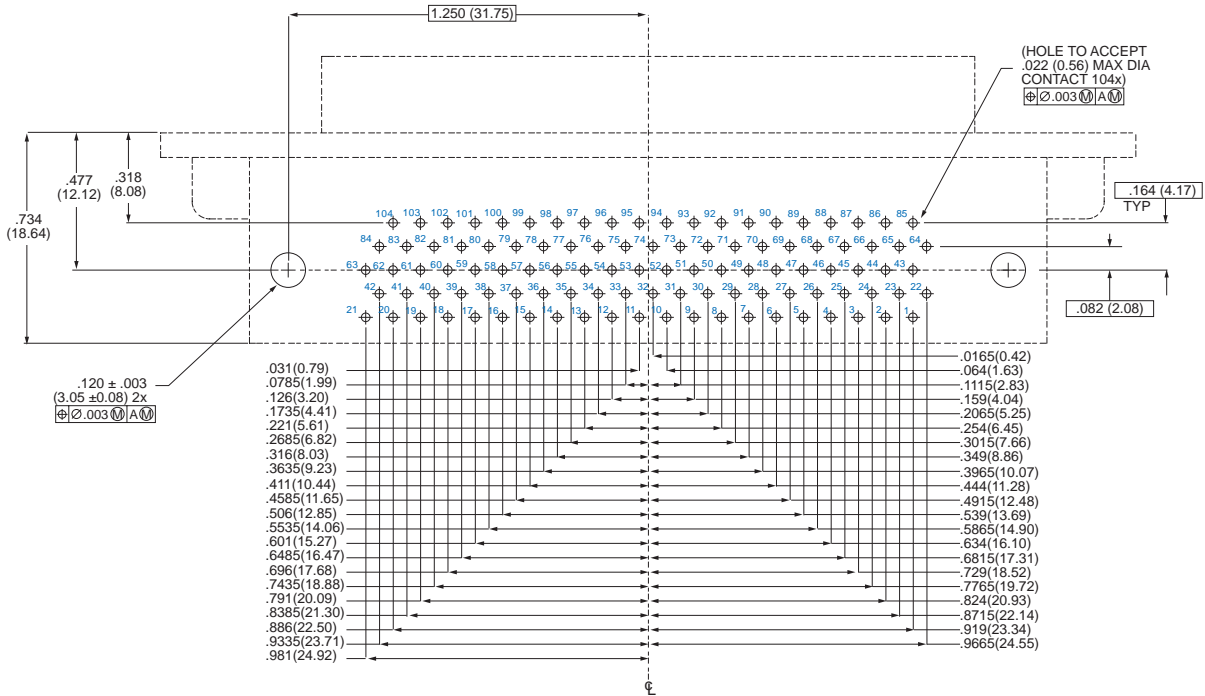

6H104  
104 #22D

Dimensions in inches (millimeters) and are subject to change without notice.

© 2011 Glenair, Inc.

CAGE Code 06324

Printed in U.S.A.

GLENAIR, INC. • 1211 AIR WAY • GLENDALE, CA 91201-2497 • 818-247-6000 • FAX 818-500-9912

www.glenair.com

G-10

E-Mail: sales@glenair.com

G

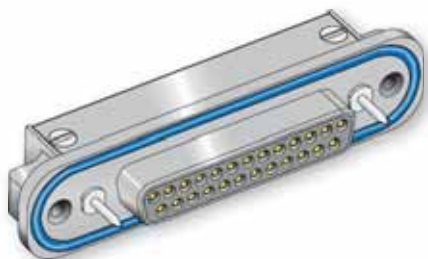
**HiPer-D Panel Mount Socket Connectors with Right Angle PC Tails**

Rear panel mount HiPer-D socket connectors feature rugged one-piece machined aluminum shell and stainless steel shroud for improved EMI protection. Contacts are non-removable size #20 or #22D straight PC tail contacts. Flange O-ring provides panel seal. Intermateable with standard M24308-type D-Subminiature connectors, the HiPer-D features environmental sealing and optional blind mate hardware. #4-40 threaded mounting holes simplify panel attachment. Threaded holes on the rear of the connector allow attachment to circuit board. Contacts are potted with epoxy. Glass-reinforced thermoset epoxy insulators. 1000 VAC, 5 Amps (#22D) or 7.5 Amps (#20).

**HOW TO ORDER**
**Sample Part Number**

280-025S	4S37	ME	B	A														
Part Number	Shell Size - Insert Arr.	Shell Material/Finish	Hardware Option	PC Tail Length														
<b>280-025S</b> HiPer-D Panel Mount Socket Connector With Right Angle PC Tails	Standard Density #20 Contacts	<b>ME</b> Aluminum with Electroless Nickel Finish <i>general purpose applications, excellent conductivity</i>	 <b>N</b> #8-32 Threaded Hole	<b>A</b> .125 inches (3.18mm)														
	<table border="0"> <tr> <th>Layout</th> <th>Contact Quantity</th> </tr> <tr> <td><b>1S9</b></td> <td>9</td> </tr> <tr> <td><b>2S15</b></td> <td>15</td> </tr> <tr> <td><b>3S25</b></td> <td>25</td> </tr> <tr> <td><b>4S37</b></td> <td>37</td> </tr> <tr> <td><b>5S50</b></td> <td>50</td> </tr> </table>			Layout	Contact Quantity	<b>1S9</b>	9	<b>2S15</b>	15	<b>3S25</b>	25	<b>4S37</b>	37	<b>5S50</b>	50	<b>MT</b> Aluminum with Nickel-PTFE Finish <i>1000 Hour Grey™ maximum corrosion protection, durability, and excellent conductivity (non-reflective grey)</i>	 <b>P</b> #4-40 Female Jackpost	<b>B</b> .250 inches (6.35mm)
Layout	Contact Quantity																	
<b>1S9</b>	9																	
<b>2S15</b>	15																	
<b>3S25</b>	25																	
<b>4S37</b>	37																	
<b>5S50</b>	50																	
High Density #22D Contacts	<table border="0"> <tr> <th>Layout</th> <th>Contact Quantity</th> </tr> <tr> <td><b>1H15</b></td> <td>15</td> </tr> <tr> <td><b>2H26</b></td> <td>26</td> </tr> <tr> <td><b>3H44</b></td> <td>44</td> </tr> <tr> <td><b>4H62</b></td> <td>62</td> </tr> <tr> <td><b>5H78</b></td> <td>78</td> </tr> <tr> <td><b>6H104</b></td> <td>104</td> </tr> </table>	Layout	Contact Quantity	<b>1H15</b>	15	<b>2H26</b>	26	<b>3H44</b>	44	<b>4H62</b>	62	<b>5H78</b>	78	<b>6H104</b>	104	<b>JF</b> Aluminum with Cadmium, Yellow Chromate <i>for severe environments, excellent conductivity</i>	 <b>G</b> Male Guide Pin for Blind Mating	 <b>B</b> Female Guide Bushing for Blind Mating
Layout	Contact Quantity																	
<b>1H15</b>	15																	
<b>2H26</b>	26																	
<b>3H44</b>	44																	
<b>4H62</b>	62																	
<b>5H78</b>	78																	
<b>6H104</b>	104																	

**SPECIFICATIONS**

Current Rating	#22D 5 AMPS, #20 7.5 AMPS
Test Voltage	1000 VAC RMS
Insulation Resistance	5000 megohms minimum
Operating Temperature	-65° C. to +200° C.
Ingress Protection	IP 67
Shock	300 g.
Vibration, Random	43.92 g.

**MATERIALS AND FINISHES**

Shell	Aluminum alloy
Contacts	Copper alloy, 50 microinches gold plated
Insulator	Thermoset epoxy, glass-filled
Potting Compound	Epoxy
Hardware	300 series stainless steel

Dimensions in inches (millimeters) and are subject to change without notice.

280-025S  
 Series 28 HiPer-D  
 Panel Mount Right Angle PCB Headers



HIPER-D CONTACT ARRANGEMENTS: STANDARD DENSITY, #20 CONTACTS

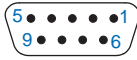

1S9  
9 #20 Contacts

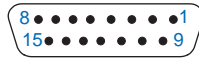

2S15  
15 #20 Contacts

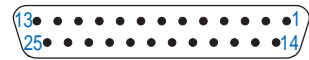

3S25  
15 #20 Contacts



4S37  
37 #20 Contacts

Mating Face of  
Socket Connector

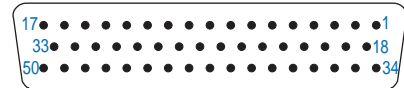

5S50  
50 #20 Contacts

HIPER-D CONTACT ARRANGEMENTS: HIGH DENSITY, #22D CONTACTS

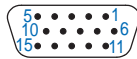

1H15  
15 #22D Contacts

Mating Face of  
Socket  
Connector



2H26  
26 #22D Contacts

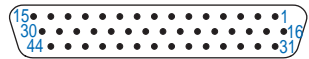

3H44  
44 #22D Contacts



4H62  
62 #22D Contacts

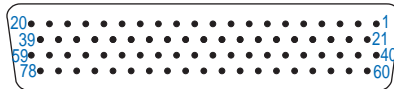

5H78  
78 #22D Contacts

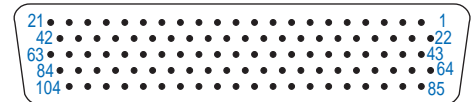

6H104  
104 #22D Contacts

HARDWARE OPTION

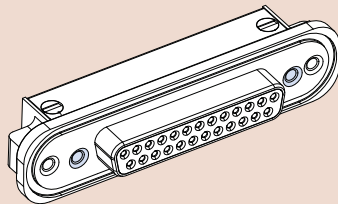

**N**  
No Mating Hardware

Connector is supplied without mating hardware. Hardware attachment holes are #8-32 UNC 2B, .150 min. deep.

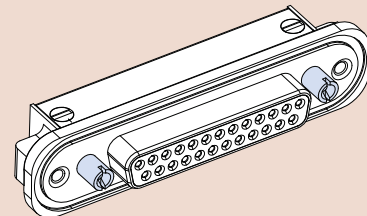

**P**  
Jackposts

Connector is supplied with non-removable stainless steel jackposts. #4-40 UNC 2B thread. Stainless steel.

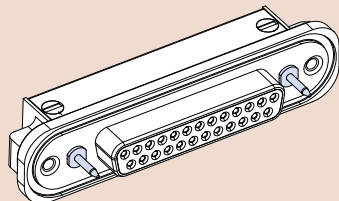

**G**  
Guide Pins

Connector is supplied with stainless steel non-removable guide pins. Mates with type "B" guide sockets on mating connector.

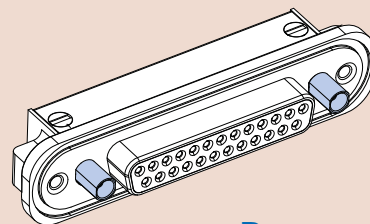

**B**  
Female Guide Bushing

Connector is supplied with stainless steel non-removable bushings. Mates with type "G" guide pins on mating connector.

Dimensions in inches (millimeters) and are subject to change without notice.



# 280-025S Series 28 HiPer-D Panel Mount Right Angle PCB Headers

## 280-025S DIMENSIONS

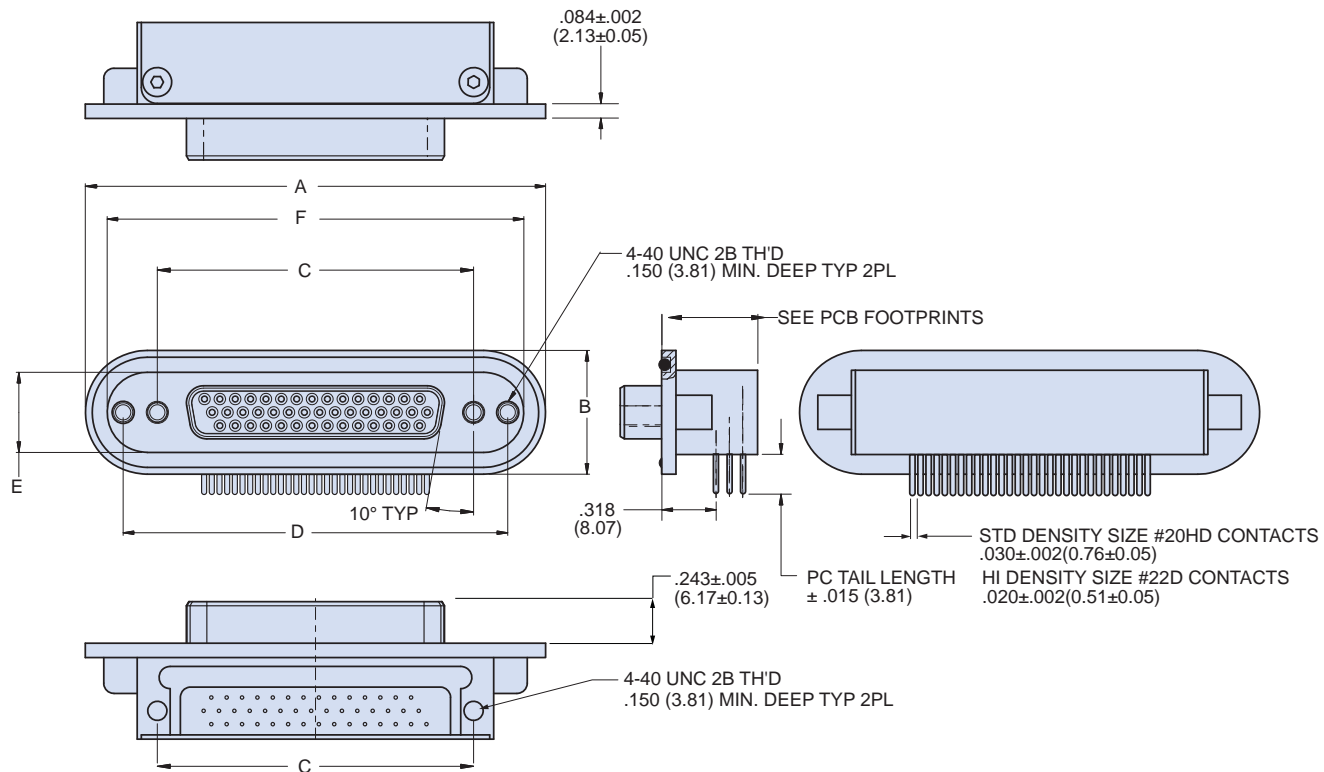

Shell Size	A		B		C Basic		D Basic		E		F	
	in	mm	in	mm	in.	mm	in	mm	in	mm	in	mm
1	1.865	47.37	.725	18.42	.984	24.99	1.424	36.17	.469	11.91	1.609	40.87
2	2.200	55.88	.725	18.42	1.312	33.32	1.752	44.50	.469	11.91	1.944	49.38
3	2.736	69.49	.725	18.42	1.852	47.04	2.292	58.22	.469	11.91	2.480	62.99
4	3.385	85.98	.725	18.42	2.500	63.50	2.940	74.68	.469	11.91	3.129	79.48
5	3.289	83.54	.837	21.26	2.406	61.11	2.846	72.29	.581	14.76	3.033	77.04
6	3.383	85.93	.899	22.83	2.500	63.50	2.940	74.68	.643	16.33	3.127	79.43

## 280-025S PANEL CUTOUT

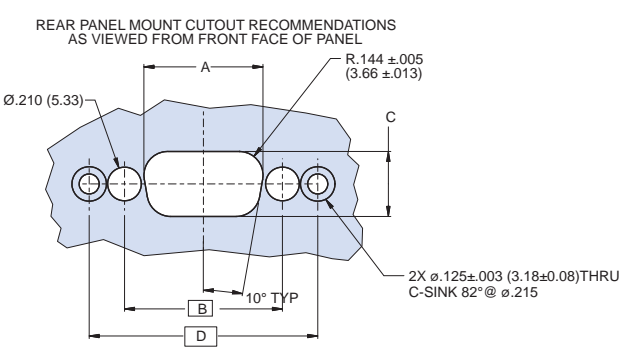

Shell Size	A		B Basic		C		D Basic	
	in	mm	in	mm	in.	mm	in	mm
1	.746	18.95	.984	24.99	.409	10.39	1.424	36.17
2	1.074	27.28	1.312	33.32	.409	10.39	1.752	44.50
3	1.614	41.00	1.852	47.04	.409	10.39	2.292	58.22
4	2.262	57.45	2.500	63.50	.409	10.39	2.940	74.68
5	2.159	54.84	2.406	61.11	.521	13.23	2.846	72.29
6	2.292	58.22	2.500	63.50	.583	14.81	2.940	74.68

Dimensions in inches (millimeters) and are subject to change without notice.

**280-029S**  
**Series 28 HiPer-D**  
**Free-Standing Right Angle PCB Headers**



Right Angle PCB

**Free-standing Right Angle PCB Socket Connectors**

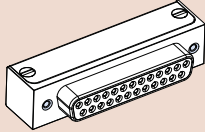

Free-standing HiPer-D socket connectors feature rugged machined aluminum shell and stainless steel cover for improved EMI protection. Contacts are non-removable size #20 or #22D. Intermateable with standard M24308-type D-Subminiature connectors, the HiPer-D features epoxy potting for environmental sealing. Threaded holes on the rear of the connector allow attachment to circuit board. Glass-reinforced thermoset epoxy insulators. 1000 VAC, 5 Amps (#22D) or 7.5 Amps (#20).

HOW TO ORDER				
Sample Part Number				
280-029S	2H26	ME	P	A
Part Number	Shell Size - Insert Arr.	Shell Material/Finish	Hardware Option	PC Tail Length
<b>280-029S</b> HiPer-D Free-standing Socket Connector With Right Angle PC Tails	Standard Density #20 Contacts  Layout <b>Contact Quantity</b> <b>1S9</b> 9 <b>2S15</b> 15 <b>3S25</b> 25 <b>4S37</b> 37 <b>5S50</b> 50	<b>ME</b> Aluminum with Electroless Nickel Finish <i>general purpose applications, excellent conductivity</i>  <b>MT</b> Aluminum with Nickel-PTFE Finish <i>1000 Hour Grey™ maximum corrosion protection, durability, and excellent conductivity (non-reflective grey)</i>	 <b>N</b> #4-40 Female Threads in Mounting Holes <i>Choose this option for rear panel mounting and order jackpost kit 289-016 separately.</i>	<b>A</b> .125 inches (3.18mm)
	High Density #22D Contacts  Layout <b>Contact Quantity</b> <b>1H15</b> 15 <b>2H26</b> 26 <b>3H44</b> 44 <b>4H62</b> 62 <b>5H78</b> 78 <b>6H104</b> 104			<b>JF</b> Aluminum with Cadmium, Yellow Chromate <i>for severe environments, excellent conductivity</i>

SPECIFICATIONS	
Current Rating	#22D 5 AMPS, #20 7.5 AMPS
Test Voltage	1000 VAC RMS
Insulation Resistance	5000 megohms minimum
Operating Temperature	-65° C. to +200° C.
Ingress Protection	IP 67
Shock	300 g.
Vibration, Random	43.92 g.

MATERIALS AND FINISHES	
Shell	Aluminum alloy
Contacts	Copper alloy, 50 microinches gold plated
insulator	Thermoset epoxy, glass-filled
Potting Compound	Epoxy
Hardware	300 series stainless steel

Dimensions in inches (millimeters) and are subject to change without notice.

G





# 280-029S Series 28 HiPer-D Free-Standing Right Angle PCB Headers

## HIPER-D CONTACT ARRANGEMENTS (MATING FACE OF SOCKET CONNECTOR)

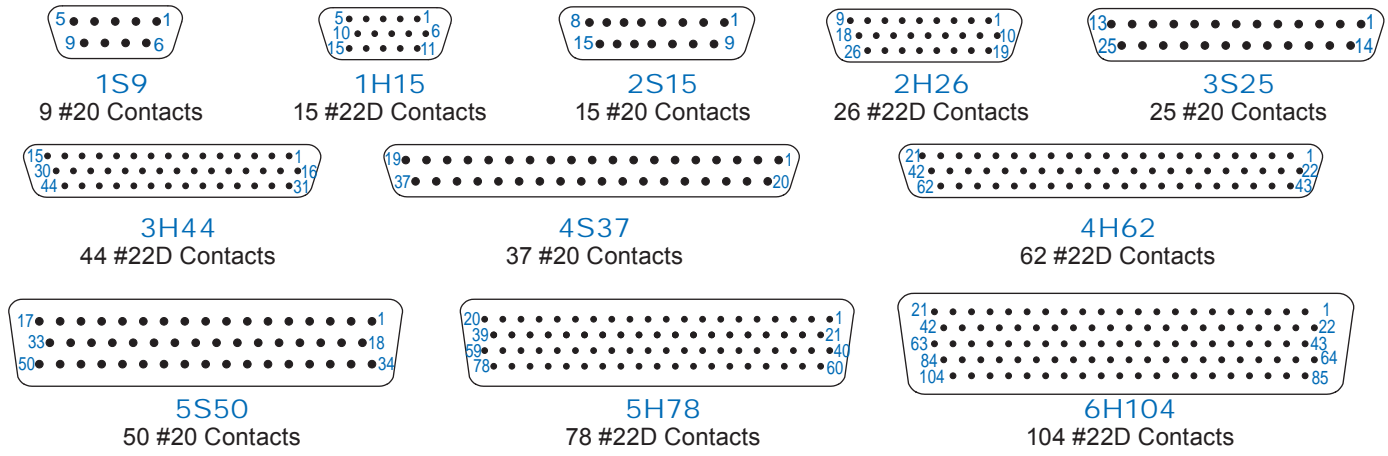

## 280-029S DIMENSIONS

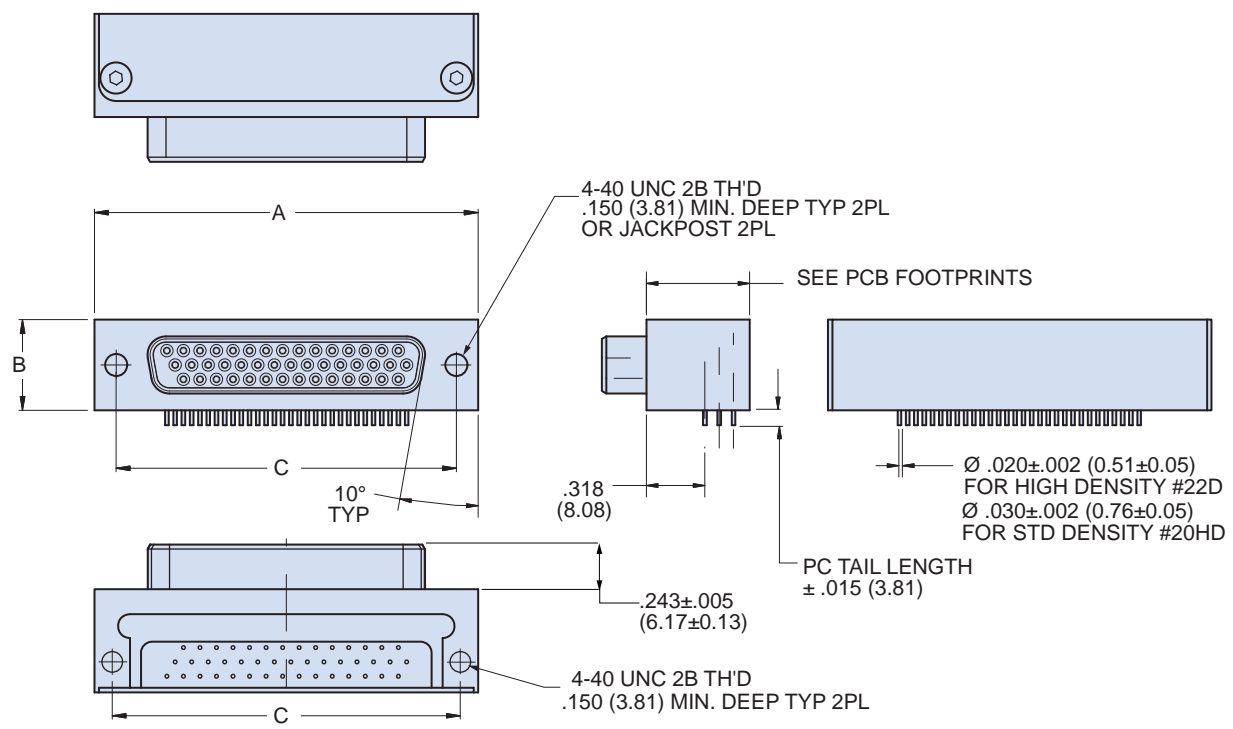

Shell Size	A		B		C Basic	
	in ±.015	mm ± 0.38	in ±.015	mm ± 0.38	in.	mm
1	1.213	30.81	.494	12.55	.984	24.99
2	1.541	39.14	.494	12.55	1.312	33.32
3	2.088	53.04	.494	12.55	1.852	47.04
4	2.729	69.32	.494	12.55	2.500	63.50
5	2.635	66.93	.605	15.37	2.406	61.11
6	2.729	69.32	.668	16.97	2.500	63.50

Dimensions in inches (millimeters) and are subject to change without notice.

280-025S and 280-029S  
Printed Circuit Board Mounting Patterns  
HiPer-D Right Angle Headers



Right Angle  
PCB

280-025S AND 280-029S PRINTED CIRCUIT BOARD PATTERNS

Component Mounting Side of PCB

1S9  
9 #20

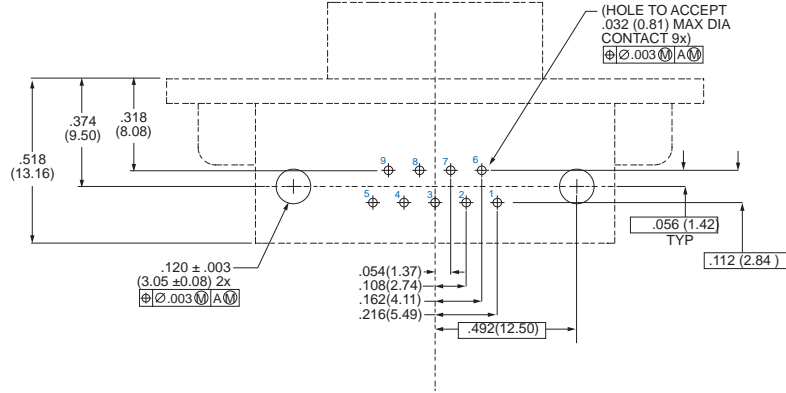

2S15  
15 #20

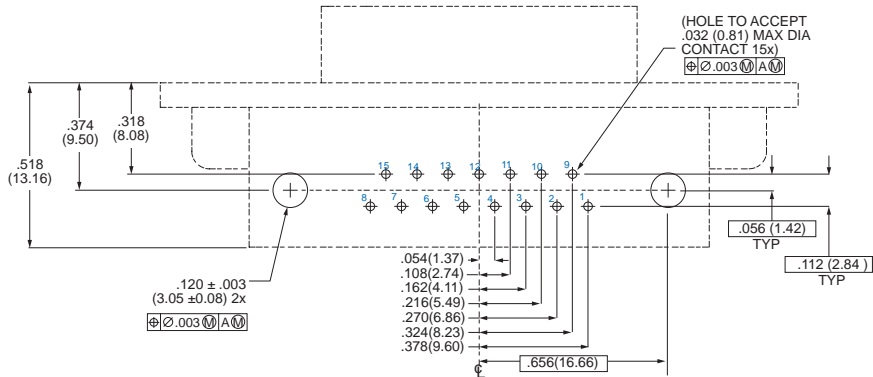

3S25  
25 #20

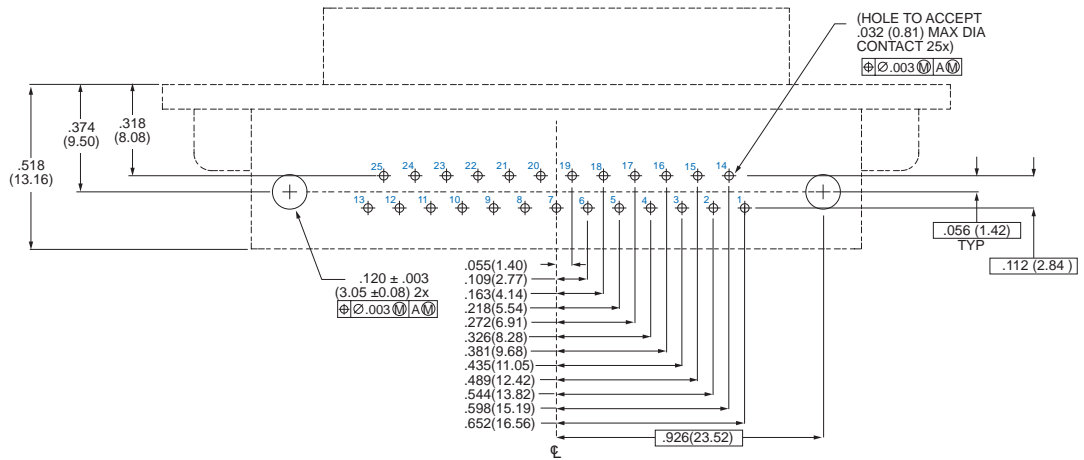

G

Dimensions in inches (millimeters) and are subject to change without notice.



# 280-025S and 280-029S Printed Circuit Board Mounting Patterns HiPer-D Right Angle Headers

## 280-025S AND 280-029S PRINTED CIRCUIT BOARD PATTERNS Component Mounting Side of PCB

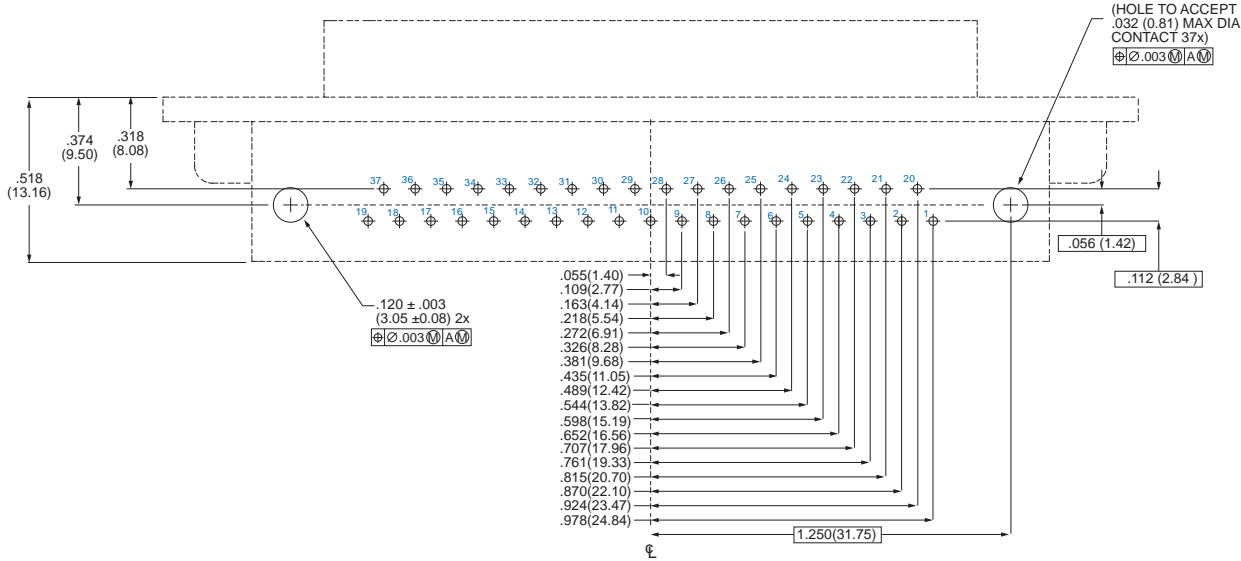

**4S37**  
37 #20

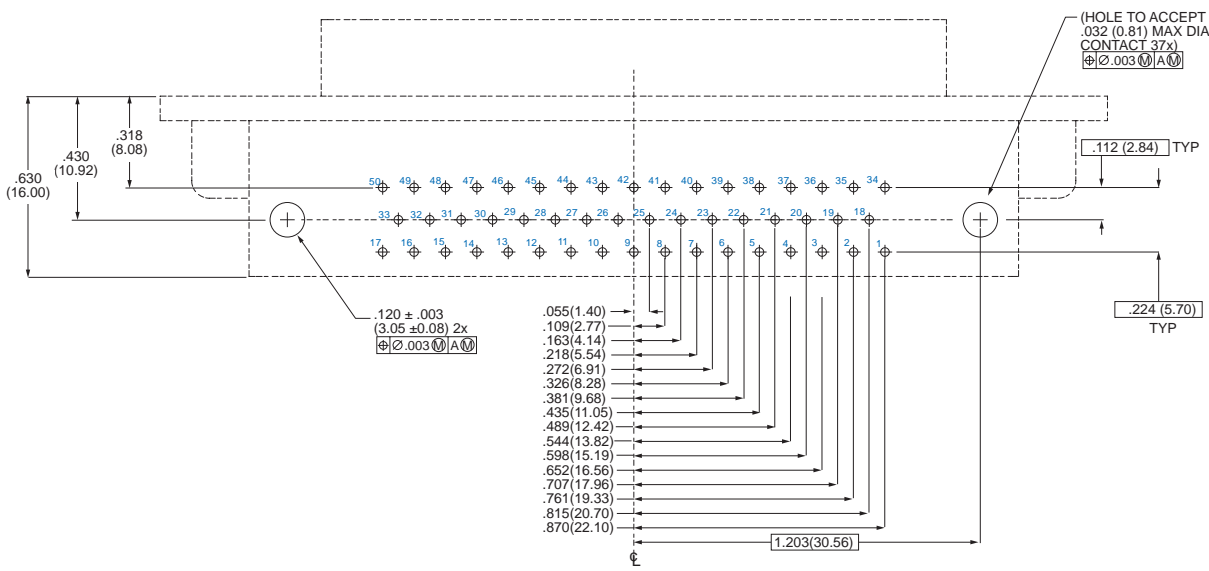

**5S50**  
50 #20

Dimensions in inches (millimeters) and are subject to change without notice.

280-025S and 280-029S  
Printed Circuit Board Mounting Patterns  
HiPer-D Right Angle Headers



Right Angle  
PCB

280-025S AND 280-029S PRINTED CIRCUIT BOARD PATTERNS

Component Mounting Side of PCB

1H15  
15 #22D

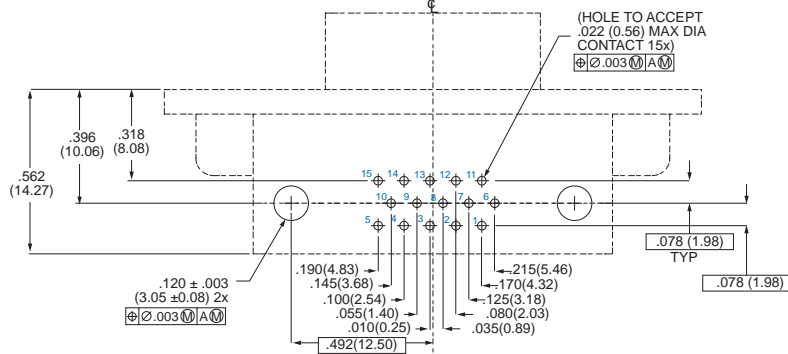

2H26  
26 #22D

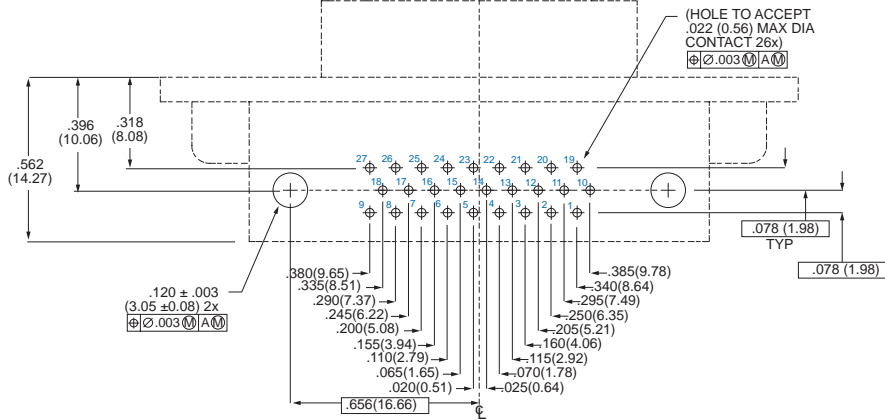

3H44  
44 #22D

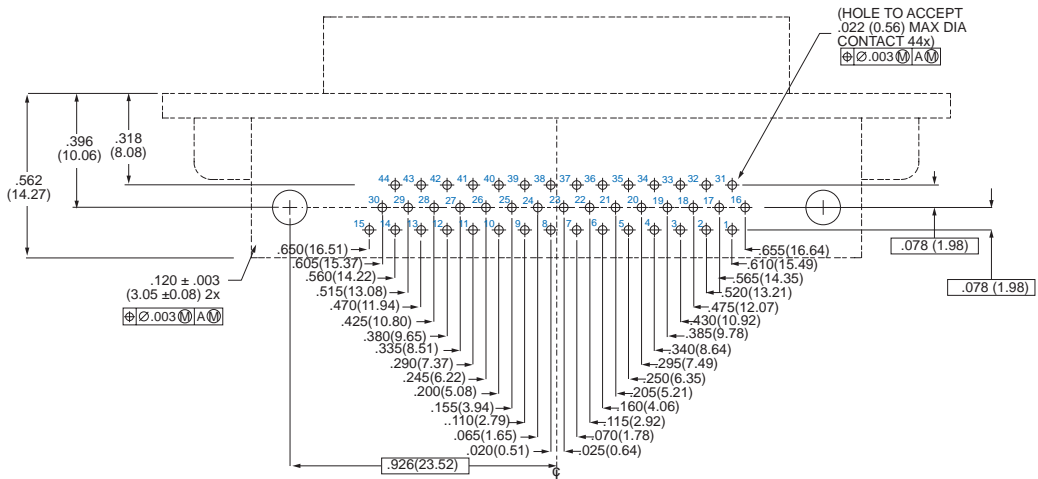

Dimensions in inches (millimeters) and are subject to change without notice.

G



# 280-025S and 280-029S Printed Circuit Board Mounting Patterns

## HiPer-D Right Angle Headers

### 280-025S AND 280-029S PRINTED CIRCUIT BOARD PATTERNS

#### Component Mounting Side of PCB

**4H62**  
62 #22D

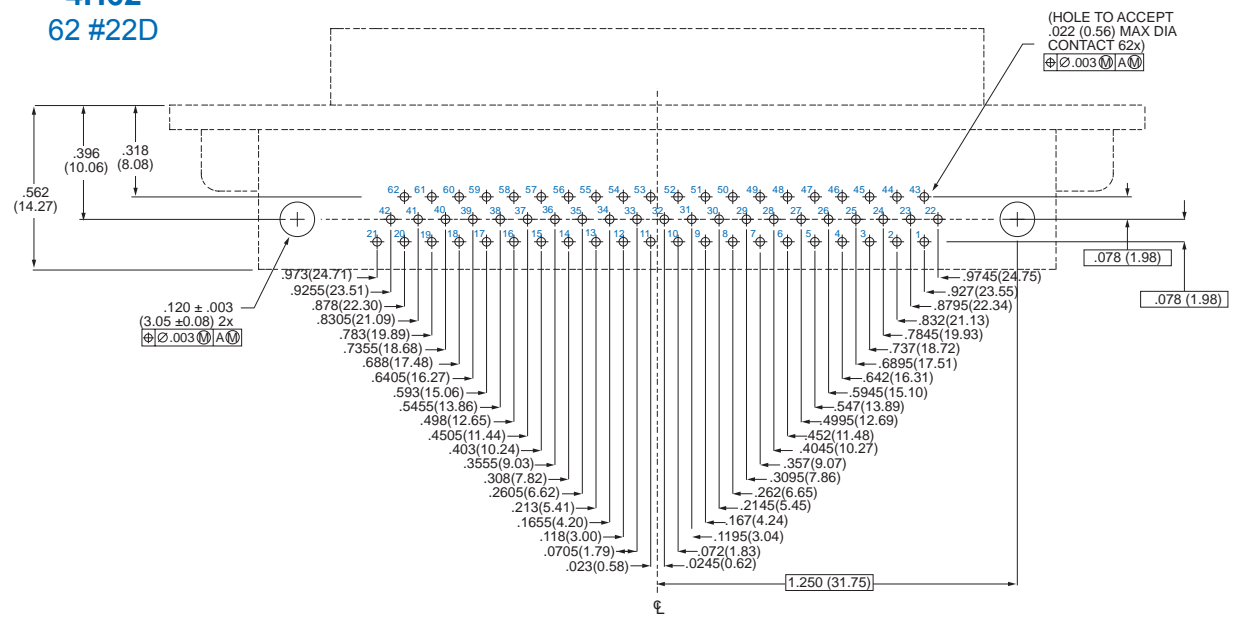

**5H78**  
78 #22D

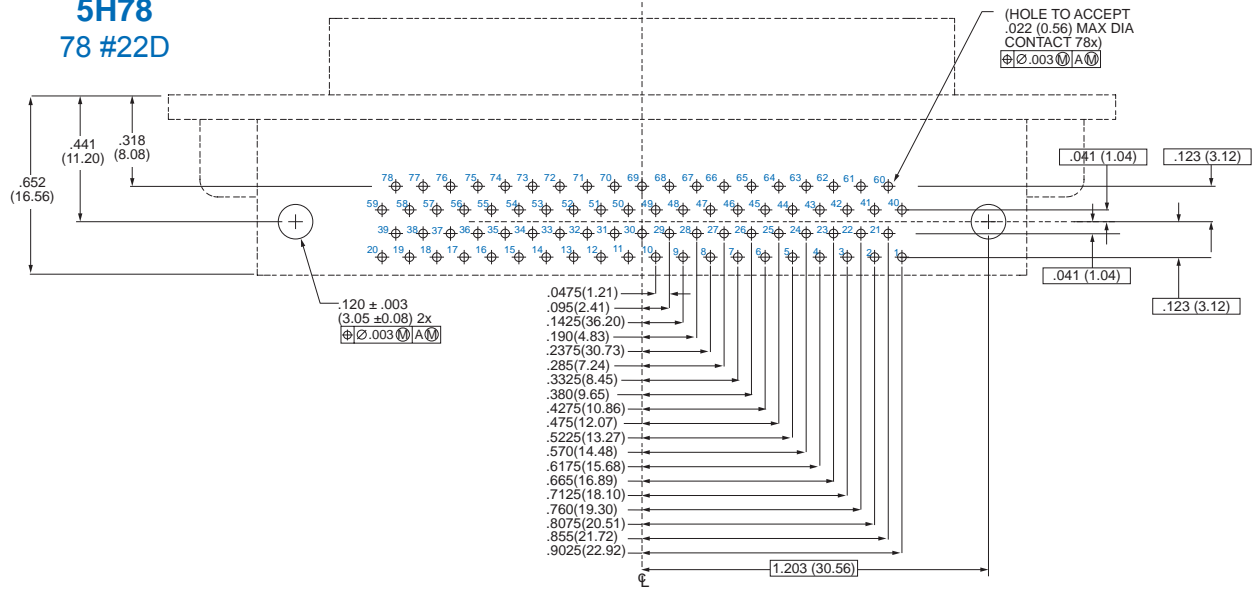

Dimensions in inches (millimeters) and are subject to change without notice.



280-025S and 280-029S  
 Printed Circuit Board Mounting Patterns  
 HiPer-D Right Angle Headers



Right Angle  
 PCB

280-025S AND 280-029S PRINTED CIRCUIT BOARD PATTERNS

Component Mounting Side of PCB

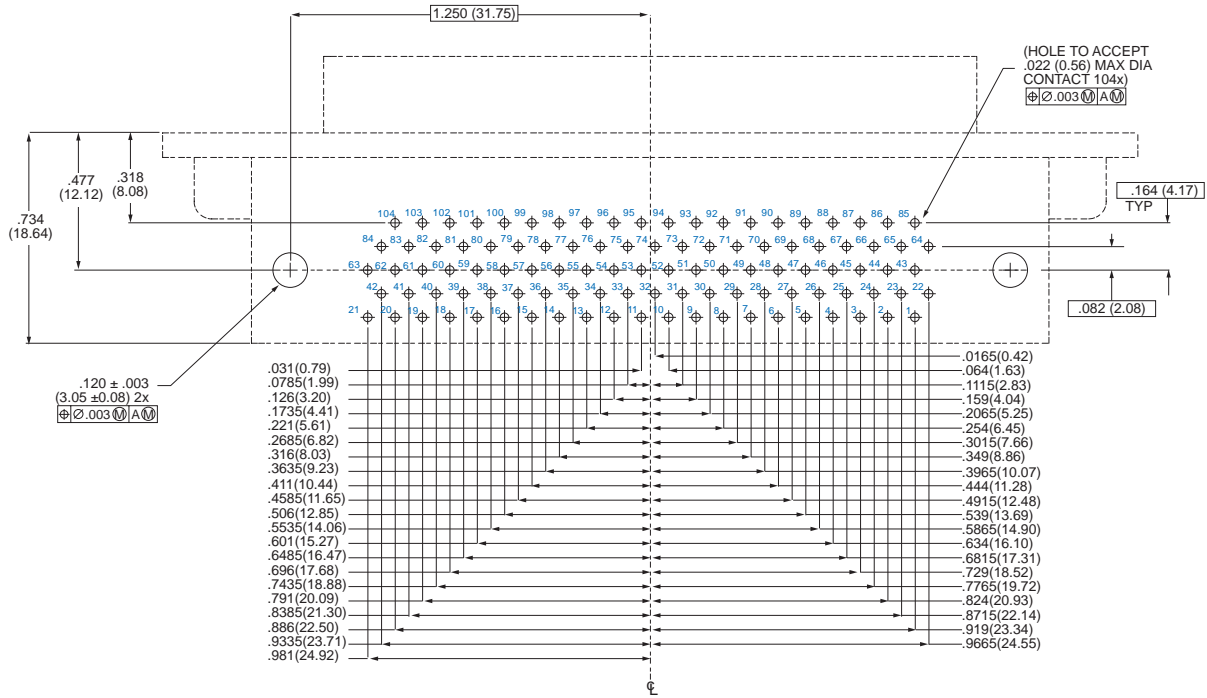

6H104  
 104 #22D

Dimensions in inches (millimeters) and are subject to change without notice.

G

SERIES 28

# HiPer-D

CONNECTOR BACKSHELLS AND ACCESSORIES



Glenair's complete line of backshells and accessories for Series 28 HiPer-D connectors includes: Protective covers for watertight sealing; low-profile, space-saving backshells with optional Band-Master™ ATS clamping bands for shield termination, and Glenair Series 77 lipped shrink boot compatibility; environmental backshells for watertight EMI protection, compatible with Glenair Series 77 heat-shrink boots; connector adapters in straight, 45° and 90° configurations; stainless steel jackposts for panel mounting; and Glenair HiPer-D Sav-Cons® to protect circuits from EMI problems and mechanical damage.



# 289-003, 289-004 and 289-019 HiPer-D Protective Covers



## HiPer-D Protective Covers

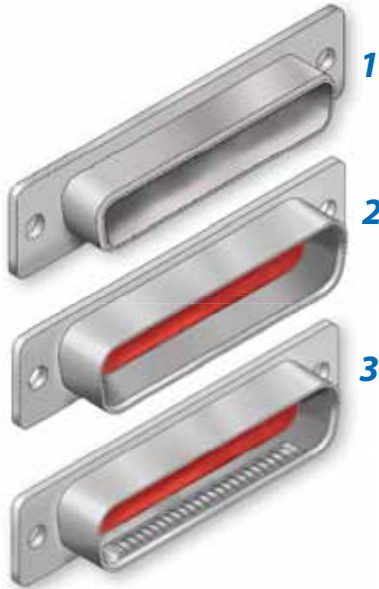

Protective covers fit Glenair Series 28 HiPer-D connectors and MIL-DTL-24308 connectors. Cover for pin connector fits inside connector shell and seats on connector face seal for watertight protection. Cover for socket connector fits over connector shell and has rubber gasket. Attach to panel with optional stainless steel lanyard and ring terminal.

- 1** Cover for use with HiPer-D pin connectors. Part number 289-003.
- 2** Cover for use with HiPer-D socket connectors. Supplied without EMI spring. Fluorosilicone rubber gasket. Part number 289-019.
- 3** Cover for use with HiPer-D socket connectors. Supplied with EMI spring. Fluorosilicone rubber gasket. Part number 289-004.

PROTECTIVE COVER COMPATIBILITY TABLE			
Part Number	Fig.	Fits HiPer-D Connectors:	Fits M24308 connectors:
<b>289-003</b>	1	280-018P, 280-020P, 280-022P, 280-024P, 280-026P, 280-028P, 280-030P	M24308/3, /4, /7, /8, /9, /24, /28
<b>289-004, 289-019</b>	2, 3	280-019S, 280-021S, 280-023S, 280-025S, 280-027S, 280-029S, 280-031S	M24308/1, /2, /5, /6, /23, /27

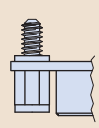
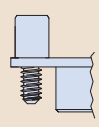
HOW TO ORDER					
Sample Part Number					
289-003	3	ME	P	N	4
Part Number	Shell Size	Shell Material and Finish	Hardware Option	Lanyard Type	Attachment Length in inches
<b>289-003</b> Cover for Pin Connector <i>Fig. 1</i>  <b>289-019</b> Cover for Socket Connector, No EMI Spring <i>Fig. 2</i>  <b>289-004</b> Cover for Socket Connector, With EMI Spring <i>Fig. 3</i>	<b>1</b> Fits 1S9 and 1H15	<b>ME</b> Aluminum with Electroless Nickel Finish <i>general purpose applications, excellent conductivity</i>	<b>N</b> None	<b>N</b> No Attachment	<i>Omit for Lanyard Type N (No Attachment).</i>  <b>2</b> <b>3</b> <b>4</b> <b>5</b> <b>6</b>
	<b>2</b> Fits 2S15 and 2H26	<b>MT</b> Aluminum with Nickel-PTFE Finish <i>1000 Hour Grey™ maximum corrosion protection, durability, and excellent conductivity (non-reflective grey)</i>		<b>F</b> Nylon-Coated Stainless Steel Lanyard, with Ring Terminal	
	<b>3</b> Fits 3S25 and 3H44		<b>P</b> Female #4-40 Stainless Steel Jackposts	<b>H</b> Teflon®-Coated Stainless Steel Lanyard, with Ring Terminal	
	<b>4</b> Fits 4S37 and 4H62	<b>JF</b> Aluminum with Cadmium, Yellow Chromate <i>for severe environments, excellent conductivity</i>		<b>S</b> Captive Stainless Steel Hex Head Jackposts with #4-40 Male Threads	
	<b>5</b> Fits 5S50 and 5H78		<i>Other materials and finishes are available. Refer to page B-2 for additional choices.</i>		
	<b>6</b> Fits 6H104				

Dimensions in inches (millimeters) and are subject to change without notice.

## 289-003, 289-004 and 289-019 Series 28 HiPer-D Protective Covers

### 289-003 DIMENSIONS

Shell Size	A		B		C Basic	
	in	mm	in	mm	in.	mm
1	1.213	30.81	.494	12.55	.984	24.99
2	1.541	39.14	.494	12.55	1.312	33.32
3	2.088	53.04	.494	12.55	1.852	47.04
4	2.729	69.32	.494	12.55	2.500	63.50
5	2.635	66.93	.605	15.37	2.406	61.11
6	2.729	69.32	.668	16.97	2.500	63.50

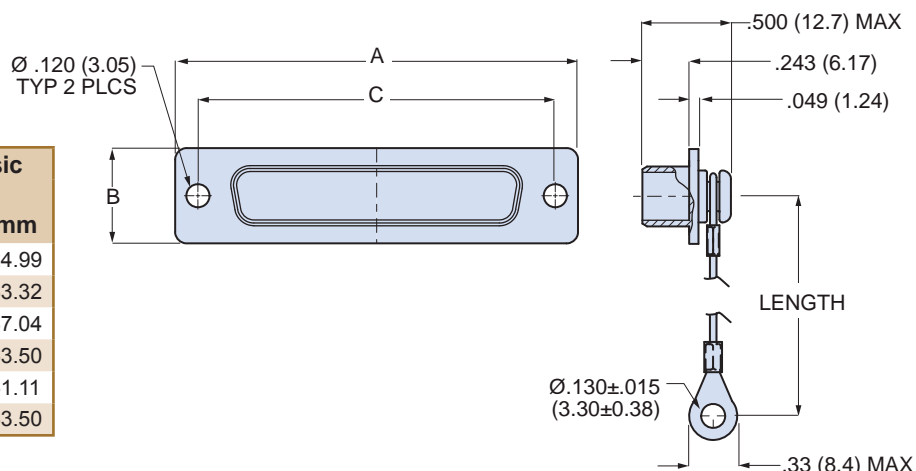

### 289-019 DIMENSIONS

Shell Size	A		B		C Basic	
	in	mm	in	mm	in.	mm
1	1.213	30.81	.494	12.55	.984	24.99
2	1.541	39.14	.494	12.55	1.312	33.32
3	2.088	53.04	.494	12.55	1.852	47.04
4	2.729	69.32	.494	12.55	2.500	63.50
5	2.635	66.93	.605	15.37	2.406	61.11
6	2.729	69.32	.668	16.97	2.500	63.50

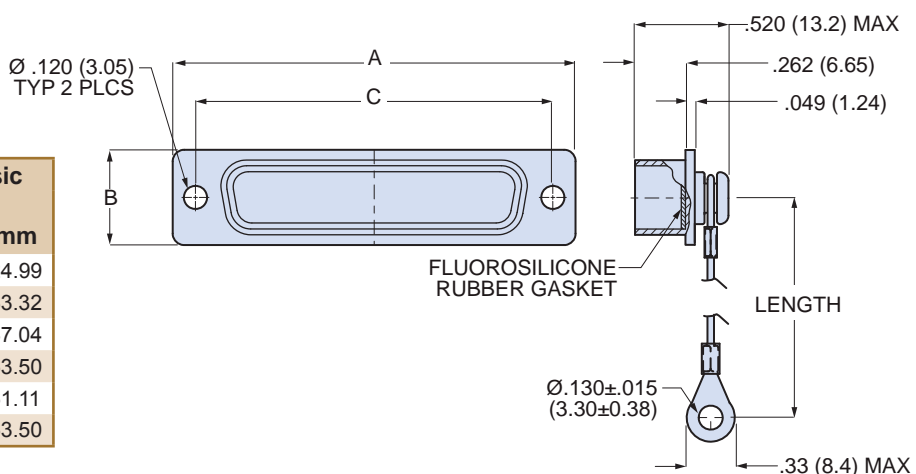

### 289-004 DIMENSIONS

Shell Size	A		B		C Basic	
	in	mm	in	mm	in.	mm
1	1.213	30.81	.494	12.55	.984	24.99
2	1.541	39.14	.494	12.55	1.312	33.32
3	2.088	53.04	.494	12.55	1.852	47.04
4	2.729	69.32	.494	12.55	2.500	63.50
5	2.635	66.93	.605	15.37	2.406	61.11
6	2.729	69.32	.668	16.97	2.500	63.50

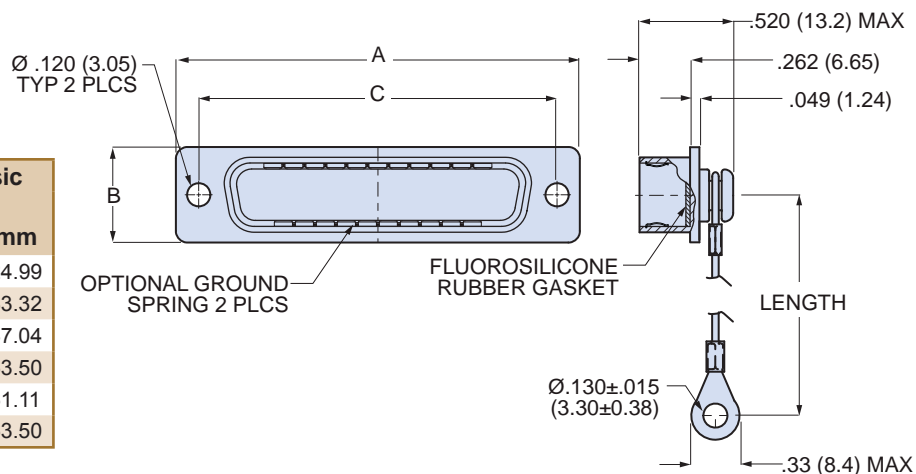

Dimensions in inches (millimeters) and are subject to change without notice.

CAGE Code 06324

Printed in U.S.A.

# 289T005 and 289S005 Series 28 HiPer-D

## EMI Backshell for HiPer-D Cable Connectors



### 289-005 EMI Backshell

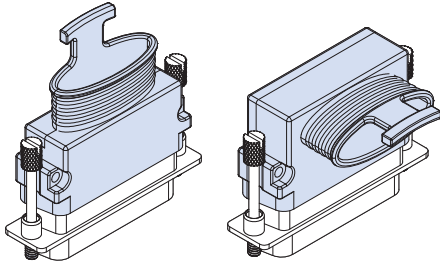



Lightweight, low profile space-saving two piece backshell fits securely into groove in 280-018P and 280-019S connectors. Terminate cable shield with optional Band-Master™ ATS clamping band. Elliptical cable entry provides room for large wire bundles. Machined aluminum alloy backshell consists of two interlocking housings and two 300 series stainless steel screws. Overlapping seam improves EMI shielding performance. Compatible with Glenair Series 77 lipped heat-shrink boots.

**This backshell is not sealed to prevent water ingress. If water ingress is a concern use 289-008 environmentally sealed backshells.**

#### HOW TO ORDER

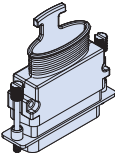
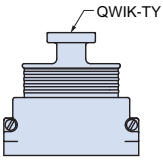
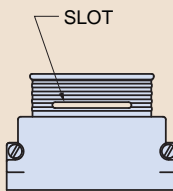
##### Sample Part Number

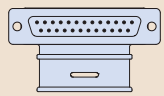
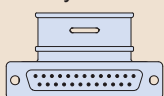
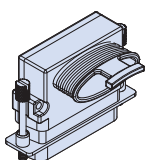
Part Number	Shell Material and Finish	Shell Size	Entry Size	Qwik Ty™ Option	Slot(s) Option	EMI/RFI Band Option	Cable Entry Direction
<b>289S005</b>	<b>MT</b>	<b>3</b>	<b>B</b>	<b>-T</b>	<b>S</b>	<b>K</b>	<b>1</b>
 <b>289T005</b> Top Entry	<b>ME</b> Aluminum with Electroless Nickel Finish <i>general purpose applications, excellent conductivity</i>	<b>1</b> Fits 1S9 and 1H15 <b>2</b> Fits 2S15 and 2H26	<b>A</b> <b>B</b> <b>C</b> <b>D</b> Select Cable Entry Size from the Table below	<b>-N</b> Supplied without Qwik Ty™ Option <b>-T</b> Qwik Ty™ Strain Relief 	<b>N</b> Supplied without Slots <b>S</b> Slots for Terminating individual Cable Shields 	<b>N</b> Supplied without Clamping Band <b>K</b> Supplied with Pre-Coiled Clamping Band <b>Part Number 600-052-1</b> 	<b>1</b> Cable Exits on Short Side of Keystone  <b>2</b> Cable Exits on Long Side of Keystone 
 <b>289S005</b> Side Entry	<b>MT</b> Aluminum with Nickel-PTFE Finish <i>1000 Hour Grey™ maximum corrosion protection, durability, and excellent conductivity (non-reflective grey)</i>	<b>3</b> Fits 3S25 and 3H44 <b>4</b> Fits 4S37 and 4H62 <b>5</b> Fits 5S50 and 5H78 <b>6</b> Fits 6H104					
	<b>JF</b> Aluminum with Cadmium, Yellow Chromate <i>for severe environments, excellent conductivity</i>						

#### CABLE ENTRY SIZE

Shell Size	SIZE A				SIZE B				SIZE C				SIZE D			
	E in.	E mm	F in.	F mm	E in.	E mm	F in.	F mm	E in.	E mm	F in.	F mm	E in.	E mm	F in.	F mm
<b>1</b>	.143	3.63	.143	3.63	.195	4.95	.195	4.95	.242	6.15	.242	6.15	.438	11.13	.375	9.53
<b>2</b>	.188	4.78	.188	4.78	.256	6.50	.256	6.50	.480	12.19	.375	9.53	.688	17.48	.375	9.53
<b>3</b>	.245	6.22	.245	6.22	.550	13.97	.375	9.53	.780	19.81	.375	9.53	1.125	28.58	.375	9.53
<b>4</b>	.291	7.39	.291	7.39	.800	20.32	.375	9.53	1.260	32.00	.375	9.53	1.813	46.05	.375	9.53
<b>5</b>	.326	8.28	.326	8.28	.770	19.56	.485	12.32	1.250	31.75	.485	12.32	1.750	44.45	.485	12.32
<b>6</b>	.376	9.55	.376	9.55	.863	21.92	.550	13.97	1.323	33.60	.550	13.97	1.875	47.63	.550	13.97

Dimensions in inches (millimeters) and are subject to change without notice.

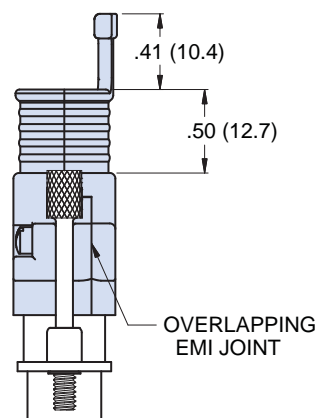
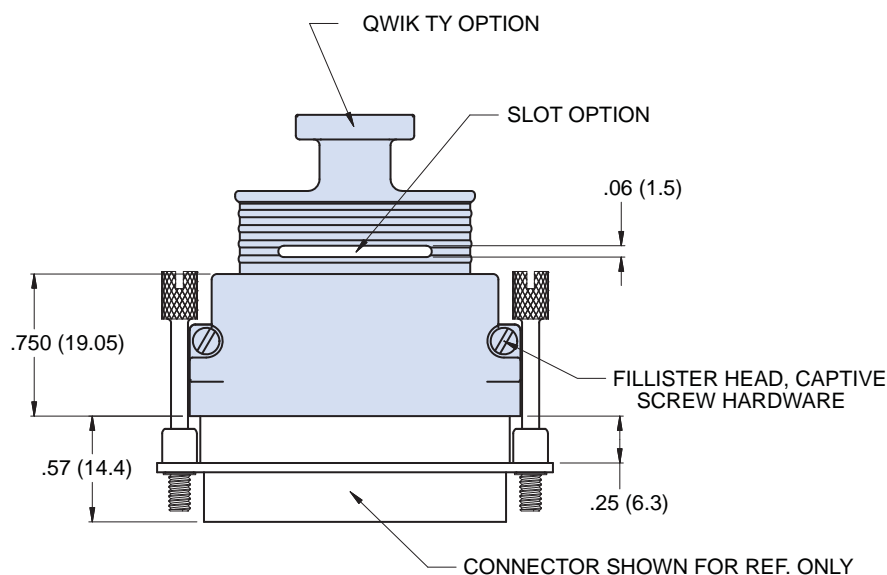
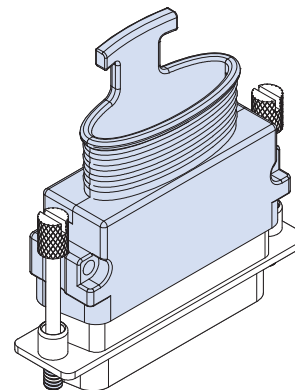
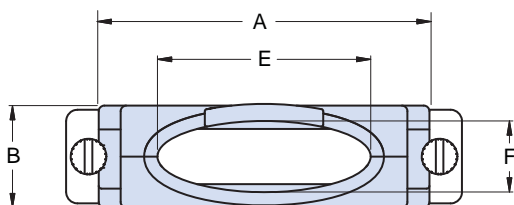

**289T005 EMI Backshell with Top Exit**

**DIMENSIONS**

Shell Size	A Max		B Max		Entry Size A				Entry Size B				Entry Size C				Entry Size D			
	in.	mm	in.	mm	E	F	E	F	E	F	E	F	E	F	E	F	E	F		
1	.894	22.71	.550	13.97	.143	3.63	.143	3.63	.195	4.95	.195	4.95	.242	6.15	.242	6.15	.438	11.13	.375	9.53
2	1.218	30.94	.550	13.97	.188	4.78	.188	4.78	.256	6.50	.256	6.50	.480	12.19	.375	9.53	.688	17.48	.375	9.53
3	1.760	44.70	.550	13.97	.245	6.22	.245	6.22	.550	13.97	.375	9.53	.780	19.81	.375	9.53	1.125	28.58	.375	9.53
4	2.408	61.16	.550	13.97	.291	7.39	.291	7.39	.800	20.32	.375	9.53	1.260	32.00	.375	9.53	1.813	46.05	.375	9.53
5	2.297	58.34	.654	16.61	.326	8.28	.326	8.28	.770	19.56	.485	12.32	1.250	31.75	.485	12.32	1.750	44.45	.485	12.32
6	2.422	61.52	.716	18.19	.376	9.55	.376	9.55	.863	21.92	.550	13.97	1.323	33.60	.550	13.97	1.875	47.63	.550	13.97

Dimensions in inches (millimeters) and are subject to change without notice.

**289S005**  
**Series 28 HiPer-D**  
**EMI Backshell, Side Exit**



**289S005 EMI Backshell with Side Exit**

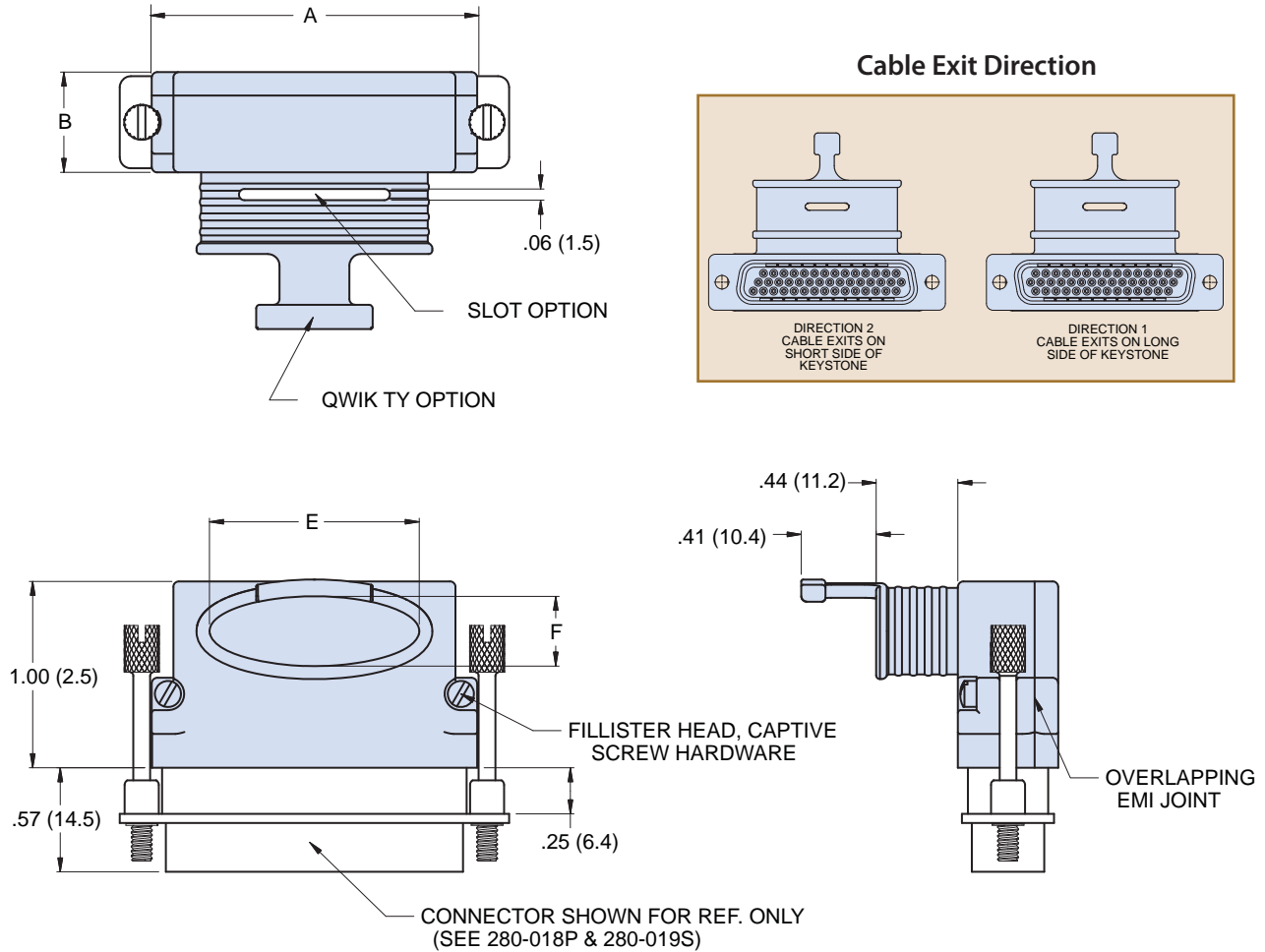

**DIMENSIONS**

Shell Size	A Max		B Max		Entry Size A				Entry Size B				Entry Size C				Entry Size D			
	in.	mm	in.	mm	E		F		E		F		E		F		E		F	
					in.	mm	in.	mm	in.	mm	in.	mm	in.	mm	in.	mm	in.	mm	in.	mm
1	.894	22.71	.550	13.97	.143	3.63	.143	3.63	.195	4.95	.195	4.95	.242	6.15	.242	6.15	.438	11.13	.375	9.53
2	1.218	30.94	.550	13.97	.188	4.78	.188	4.78	.256	6.50	.256	6.50	.480	12.19	.375	9.53	.688	17.48	.375	9.53
3	1.760	44.70	.550	13.97	.245	6.22	.245	6.22	.550	13.97	.375	9.53	.780	19.81	.375	9.53	1.125	28.58	.375	9.53
4	2.408	61.16	.550	13.97	.291	7.39	.291	7.39	.800	20.32	.375	9.53	1.260	32.00	.375	9.53	1.813	46.05	.375	9.53
5	2.297	58.34	.654	16.61	.326	8.28	.326	8.28	.770	19.56	.485	12.32	1.250	31.75	.485	12.32	1.750	44.45	.485	12.32
6	2.422	61.52	.716	18.19	.376	9.55	.376	9.55	.863	21.92	.550	13.97	1.323	33.60	.550	13.97	1.875	47.63	.550	13.97

Dimensions in inches (millimeters) and are subject to change without notice.



## 289T008, 289S008 Series 28 HiPer-D EMI Backshell, Environmental

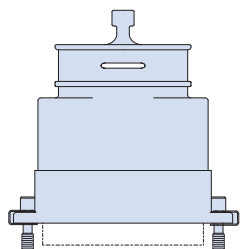

### 289-008 EMI Environmental Backshell



289-008 backshell provides watertight EMI protection for HiPer-D connectors. Fits 280-018P and 280-019S cable connectors. Available with top entry or side entry. Terminate cable shield with optional Band-Master™ ATS clamping band. Elliptical cable entry provides room for large wire bundles. Backshell consists of solid one piece aluminum housing, two stainless steel jackscrews, two jackscrew retainer clips and silicone rubber sealing gasket. Use with Glenair Series 77 heat-shrink boot.

#### HOW TO ORDER

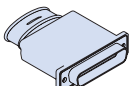
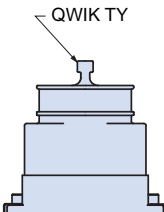
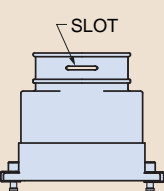
##### Sample Part Number

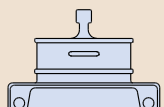
289T008	MT	3	B	-T	S	K	1							
Part Number	Shell Material and Finish	Shell Size	Entry Size	Qwik Ty™ Option	Slots Option	EMI/RFI Band Option	Cable Entry Direction							
 <b>289T008</b> Top Entry	<b>ME</b> Aluminum with Electroless Nickel Finish <i>general purpose applications, excellent conductivity</i>	<b>1</b> Fits 1S9 and 1H15	<b>A</b> <b>B</b> <b>C</b> <b>D</b>	<b>-N</b> Supplied without Qwik Ty™ Option	<b>N</b> Supplied without Slots	<b>N</b> Supplied without Clamping Band	<i>Applies to 289S008 Only. Omit for 289T008.</i>							
								<b>MT</b> Aluminum with Nickel-PTFE Finish <i>1000 Hour Grey™ maximum corrosion protection, durability, and excellent conductivity (non-reflective grey)</i>	<b>2</b> Fits 2S15 and 2H26	Select Cable Entry Size from the Table below	<b>-T</b> Qwik Ty™ Strain Relief	<b>S</b> Slots for Terminating individual Cable Shields	<b>K</b> Supplied with Pre-Coiled Clamping Band Part Number 600-052-1	<b>1</b> Cable Exits on Long Side of Keystone
									<b>JF</b> Aluminum with Cadmium, Yellow Chromate <i>for severe environments, excellent conductivity</i>		<b>3</b> Fits 3S25 and 3H44			
<b>4</b> Fits 4S37 and 4H62	<b>5</b> Fits 5S50 and 5H78	<b>2</b> Cable Exits on Short Side of Keystone												
<b>289S008</b> Side Entry	<b>JF</b> Aluminum with Cadmium, Yellow Chromate <i>for severe environments, excellent conductivity</i>	<b>6</b> Fits 6H104												

#### CABLE ENTRY SIZE

Shell Size	SIZE A				SIZE B				SIZE C				SIZE D			
	E in.	E mm	F in.	F mm	E in.	E mm	F in.	F mm	E in.	E mm	F in.	F mm	E in.	E mm	F in.	F mm
1	.143	3.63	.143	3.63	.195	4.95	.195	4.95	.242	6.15	.242	6.15	.438	11.13	.375	9.53
2	.188	4.78	.188	4.78	.256	6.50	.256	6.50	.480	12.19	.375	9.53	.688	17.48	.375	9.53
3	.245	6.22	.245	6.22	.550	13.97	.375	9.53	.780	19.81	.375	9.53	1.125	28.58	.375	9.53
4	.291	7.39	.291	7.39	.800	20.32	.375	9.53	1.260	32.00	.375	9.53	1.813	46.05	.375	9.53
5	.326	8.28	.326	8.28	.770	19.56	.485	12.32	1.250	31.75	.485	12.32	1.750	44.45	.485	12.32
6	.376	9.55	.376	9.55	.863	21.92	.550	13.97	1.323	33.60	.550	13.97	1.875	47.63	.550	13.97

Dimensions in inches (millimeters) and are subject to change without notice.

CAGE Code 06324

Printed in U.S.A.

© 2011 Glenair, Inc.

GLENAIR, INC. • 1211 AIR WAY • GLENDALE, CA 91201-2497 • 818-247-6000 • FAX 818-500-9912

www.glenair.com

H-6

E-Mail: sales@glenair.com

289T008  
 Series 28 HiPer-D  
 EMI Backshell, Environmental



289T008 EMI Environmental Backshell, Top Exit

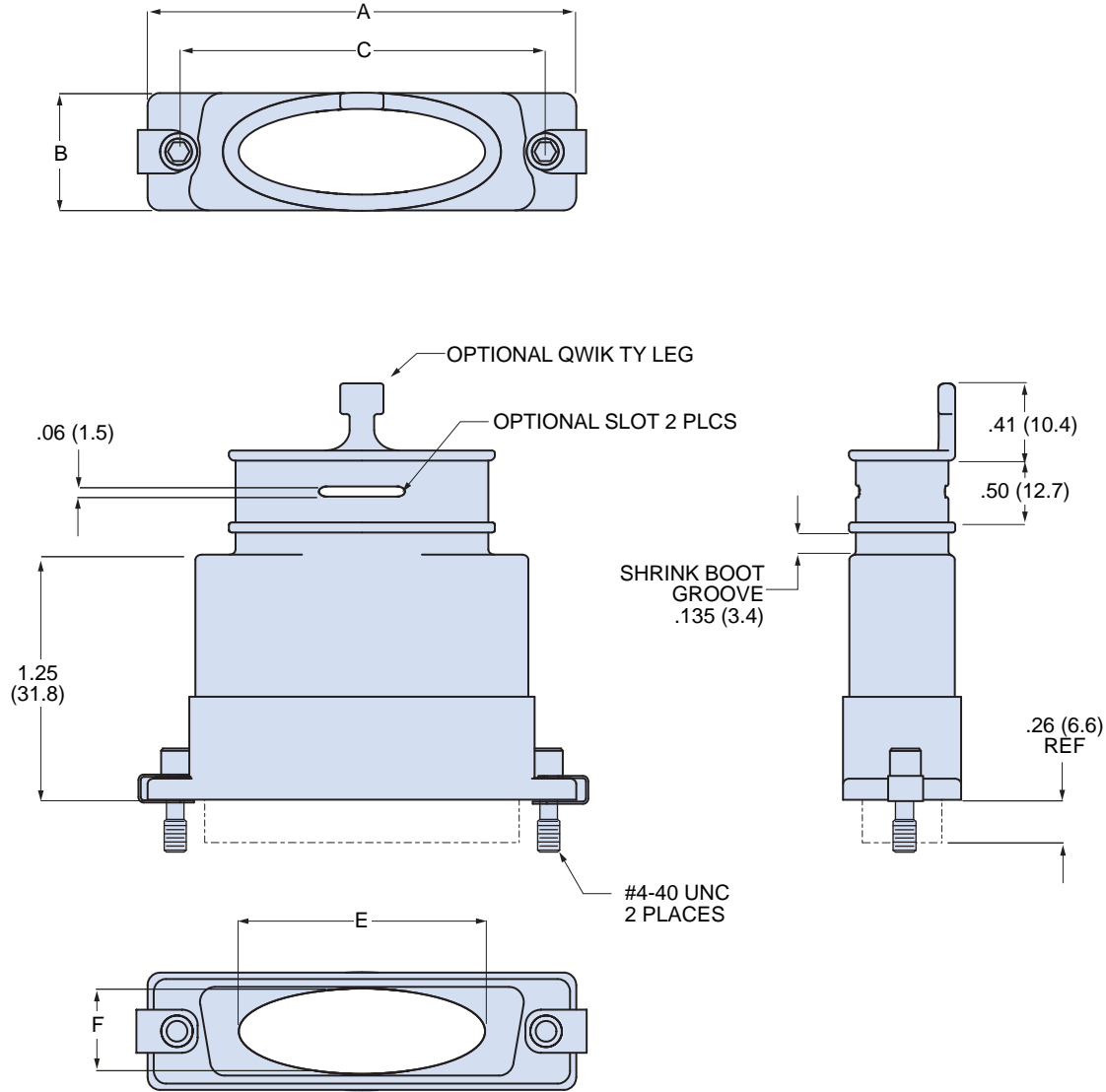

DIMENSIONS

Shell Size	A Max		B Max		C Basic		SIZE A				SIZE B				SIZE C				SIZE D			
	in.	mm	in.	mm	in.	mm	in.	mm	in.	mm	in.	mm	in.	mm	in.	mm	in.	mm	in.	mm	in.	mm
1	1.395	35.43	.624	15.85	.984	24.99	.143	3.63	.143	3.63	.195	4.95	.195	4.95	.242	6.15	.242	6.15	.438	11.13	.375	9.53
2	1.706	43.33	.624	15.85	1.312	33.32	.188	4.78	.188	4.78	.256	6.50	.256	6.50	.480	12.19	.375	9.53	.688	17.48	.375	9.53
3	2.265	57.53	.624	15.85	1.852	47.04	.245	6.22	.245	6.22	.550	13.97	.375	9.53	.780	19.81	.375	9.53	1.125	28.58	.375	9.53
4	2.900	73.66	.624	15.85	2.500	63.50	.291	7.39	.291	7.39	.800	20.32	.375	9.53	1.260	32.00	.375	9.53	1.813	46.05	.375	9.53
5	2.800	71.12	.750	19.05	2.406	61.11	.326	8.28	.326	8.28	.770	19.56	.485	12.32	1.250	31.75	.485	12.32	1.750	44.45	.485	12.32
6	2.900	73.66	.844	21.44	2.500	63.50	.376	9.55	.376	9.55	.863	21.92	.550	13.97	1.323	33.60	.550	13.97	1.875	47.63	.550	13.97

Dimensions in inches (millimeters) and are subject to change without notice.



**289S008**  
**Series 28 HiPer-D**  
**EMI Backshell, Environmental**

**289S008 EMI Environmental Backshell, Side Exit**

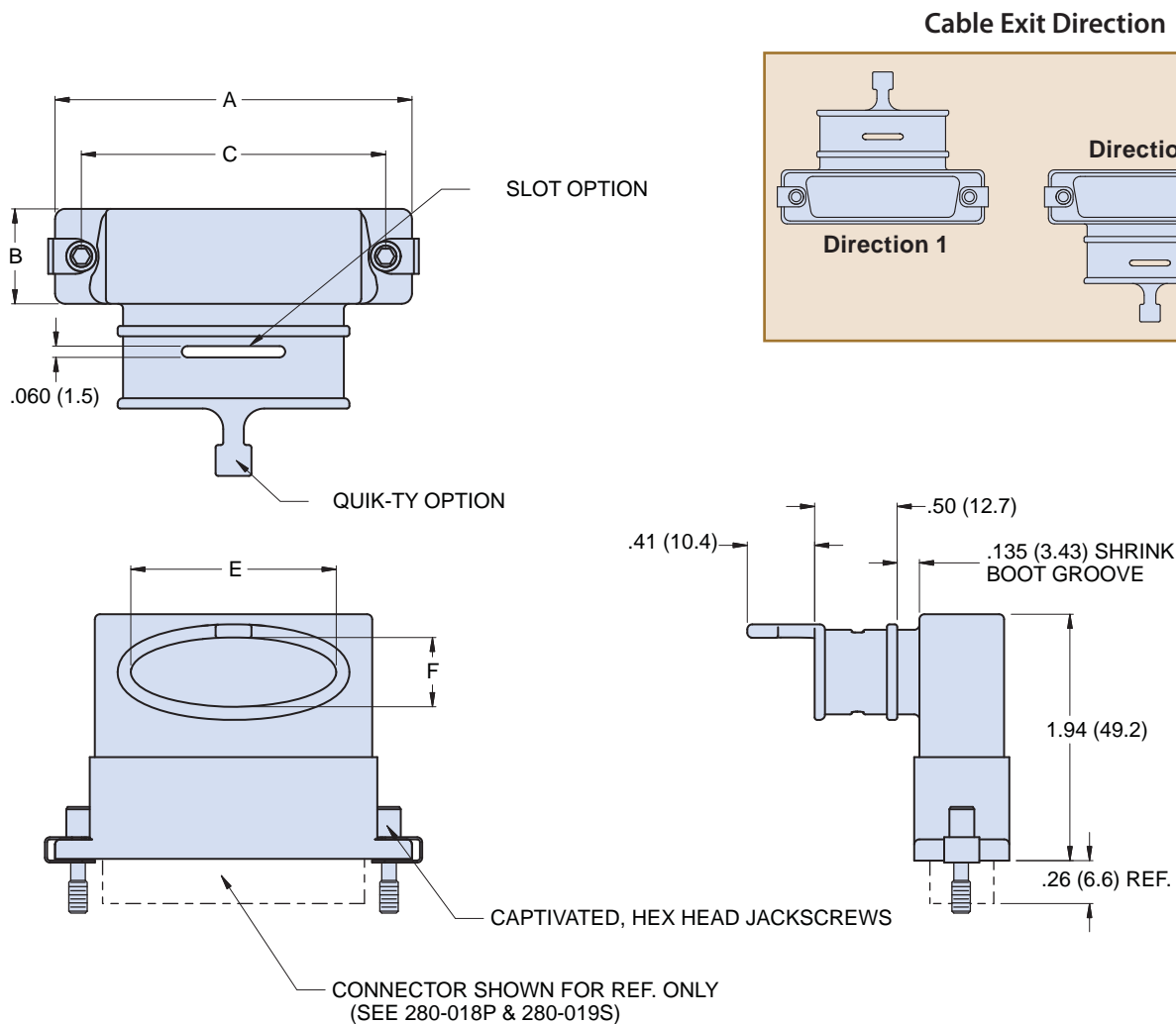

**DIMENSIONS**

Shell Size	A Max		B Max		C Basic		SIZE A				SIZE B				SIZE C				SIZE D			
	in.	mm	in.	mm	in.	mm	E	F	E	F	E	F	E	F	E	F	E	F	E	F		
<b>1</b>	1.395	35.43	.624	15.85	.984	24.99	.143	3.63	.143	3.63	.195	4.95	.195	4.95	.242	6.15	.242	6.15	.438	11.13	.375	9.53
<b>2</b>	1.706	43.33	.624	15.85	1.312	33.32	.188	4.78	.188	4.78	.256	6.50	.256	6.50	.480	12.19	.375	9.53	.688	17.48	.375	9.53
<b>3</b>	2.265	57.53	.624	15.85	1.852	47.04	.245	6.22	.245	6.22	.550	13.97	.375	9.53	.780	19.81	.375	9.53	1.125	28.58	.375	9.53
<b>4</b>	2.900	73.66	.624	15.85	2.500	63.50	.291	7.39	.291	7.39	.800	20.32	.375	9.53	1.260	32.00	.375	9.53	1.813	46.05	.375	9.53
<b>5</b>	2.800	71.12	.750	19.05	2.406	61.11	.326	8.28	.326	8.28	.770	19.56	.485	12.32	1.250	31.75	.485	12.32	1.750	44.45	.485	12.32
<b>6</b>	2.900	73.66	.844	21.44	2.500	63.50	.376	9.55	.376	9.55	.863	21.92	.550	13.97	1.323	33.60	.550	13.97	1.875	47.63	.550	13.97

Dimensions in inches (millimeters) and are subject to change without notice.



289B007, 289S007 and 289T007  
Series 28 HiPer-D

Environmental EMI Adapter for Panel Mount HiPer-D Connectors



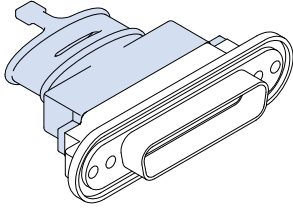

Backshells and Accessories

289-007 Environmental EMI Adapter for Panel Mount Connectors

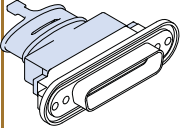
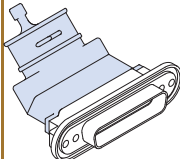
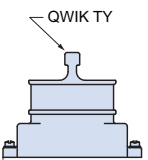
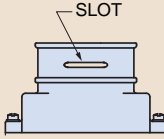

289-007 adapter attaches to the back end of panel mount HiPer-D connectors. Fits connector part numbers 280-020P, 280-021S, 280-030P and 280-031S. Available in straight, right angle and 45° versions. Aluminum alloy body, silicone rubber gasket and stainless steel screws. Design also features a boot groove for the attachment of environmental shrink boots. Terminate cable shield with optional Band-Master™ ATS band.

HOW TO ORDER

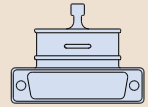
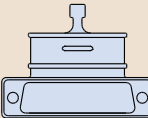
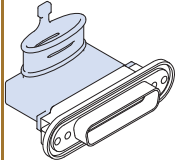
Sample Part Number							
289B007	MT	3	B	-T	S	K	1
Part Number	Shell Material and Finish	Shell Size	Entry Size	Qwik Ty™ Option	Slots Option	EMI/RFI Band Option	Cable Entry Direction
 <b>289T007</b> Top Entry	<b>ME</b> Aluminum with Electroless Nickel Finish <i>general purpose applications, excellent conductivity</i>	<b>1</b> Fits 1S9 and 1H15	<b>A</b> <b>B</b> <b>C</b> <b>D</b>	<b>-N</b> Supplied without Qwik Ty™ Option	<b>N</b> Supplied without Slots	<b>N</b> Supplied without Clamping Band	<i>Applies to 289B007 and 289S007 Only. Omit for 289T007.</i>
		<b>2</b> Fits 2S15 and 2H26					
 <b>289B007</b> 45° Entry	<b>MT</b> Aluminum with Nickel-PTFE Finish <i>1000 Hour Grey™ maximum corrosion protection, durability, and excellent conductivity (non-reflective grey)</i>	<b>3</b> Fits 3S25 and 3H44	Select Cable Entry Size from the Table below	<b>-T</b> Qwik Ty™ Strain Relief 	<b>S</b> Slots for Terminating individual Cable Shields 	<b>K</b> Supplied with Pre-Coiled Clamping Band Part Number 600-052-1 	<b>1</b> Cable Exits on Long Side of Keystone 
		<b>4</b> Fits 4S37 and 4H62					<b>2</b> Cable Exits on Short Side of Keystone 
		<b>5</b> Fits 5S50 and 5H78					
 <b>289S007</b> Side Entry	<b>JF</b> Aluminum with Cadmium, Yellow Chromate <i>for severe environments, excellent conductivity</i>	<b>6</b> Fits 6H104					

CABLE ENTRY SIZE

Shell Size	SIZE A				SIZE B				SIZE C				SIZE D			
	E in.	E mm	F in.	F mm	E in.	E mm	F in.	F mm	E in.	E mm	F in.	F mm	E in.	E mm	F in.	F mm
1	.143	3.63	.143	3.63	.195	4.95	.195	4.95	.242	6.15	.242	6.15	.438	11.13	.375	9.53
2	.188	4.78	.188	4.78	.256	6.50	.256	6.50	.480	12.19	.375	9.53	.688	17.48	.375	9.53
3	.245	6.22	.245	6.22	.550	13.97	.375	9.53	.780	19.81	.375	9.53	1.125	28.58	.375	9.53
4	.291	7.39	.291	7.39	.800	20.32	.375	9.53	1.260	32.00	.375	9.53	1.813	46.05	.375	9.53
5	.326	8.28	.326	8.28	.770	19.56	.485	12.32	1.250	31.75	.485	12.32	1.750	44.45	.485	12.32
6	.376	9.55	.376	9.55	.863	21.92	.550	13.97	1.323	33.60	.550	13.97	1.875	47.63	.550	13.97

Dimensions in inches (millimeters) and are subject to change without notice.

CAGE Code 06324

Printed in U.S.A.

© 2011 Glenair, Inc.

GLENAIR, INC. • 1211 AIR WAY • GLENDALE, CA 91201-2497 • 818-247-6000 • FAX 818-500-9912

www.glenair.com

H-9

E-Mail: sales@glenair.com

H

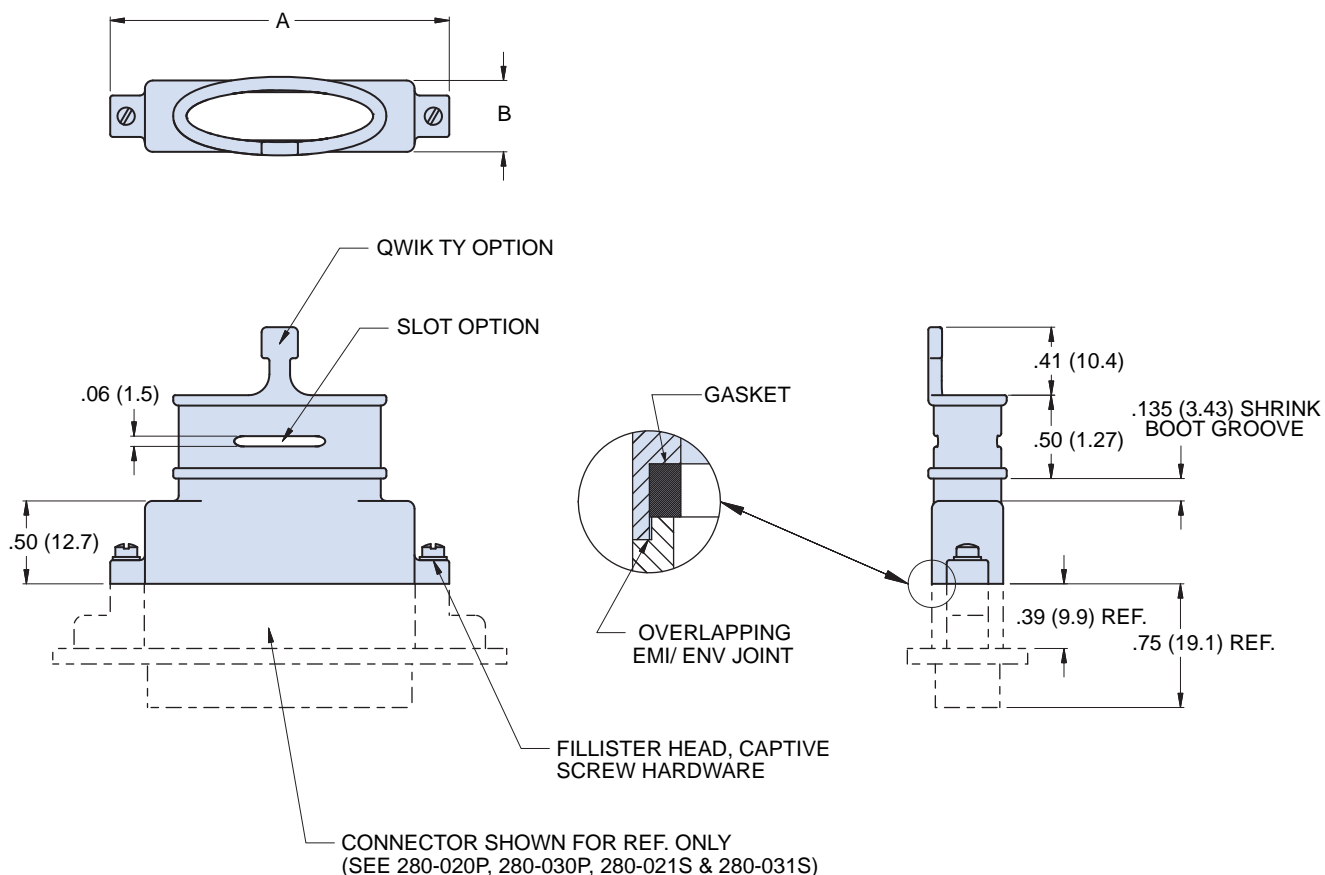
**289T007 EMI Environmental Adapter, Top Cable Exit**

**DIMENSIONS**

Shell Size	A Max		B Max		SIZE A				SIZE B				SIZE C				SIZE D			
	in.	mm	in.	mm	in.	mm	in.	mm	in.	mm	in.	mm	in.	mm	in.	mm	in.	mm	in.	mm
1	1.244	31.60	.511	12.98	.143	3.63	.143	3.63	.195	4.95	.195	4.95	.242	6.15	.242	6.15	.438	11.13	.375	9.53
2	1.572	39.39	.511	12.98	.188	4.78	.188	4.78	.256	6.50	.256	6.50	.480	12.19	.375	9.53	.688	17.48	.375	9.53
3	2.112	53.64	.511	12.98	.245	6.22	.245	6.22	.550	13.97	.375	9.53	.780	19.81	.375	9.53	1.125	28.58	.375	9.53
4	2.760	70.10	.511	12.98	.291	7.39	.291	7.39	.800	20.32	.375	9.53	1.260	32.00	.375	9.53	1.813	46.05	.375	9.53
5	2.666	67.71	.615	15.62	.326	8.28	.326	8.28	.770	19.56	.485	12.32	1.250	31.75	.485	12.32	1.750	44.45	.485	12.32
6	2.760	70.10	.630	17.27	.376	9.55	.376	9.55	.863	21.92	.550	13.97	1.323	33.60	.550	13.97	1.875	47.63	.550	13.97

Dimensions in inches (millimeters) and are subject to change without notice.

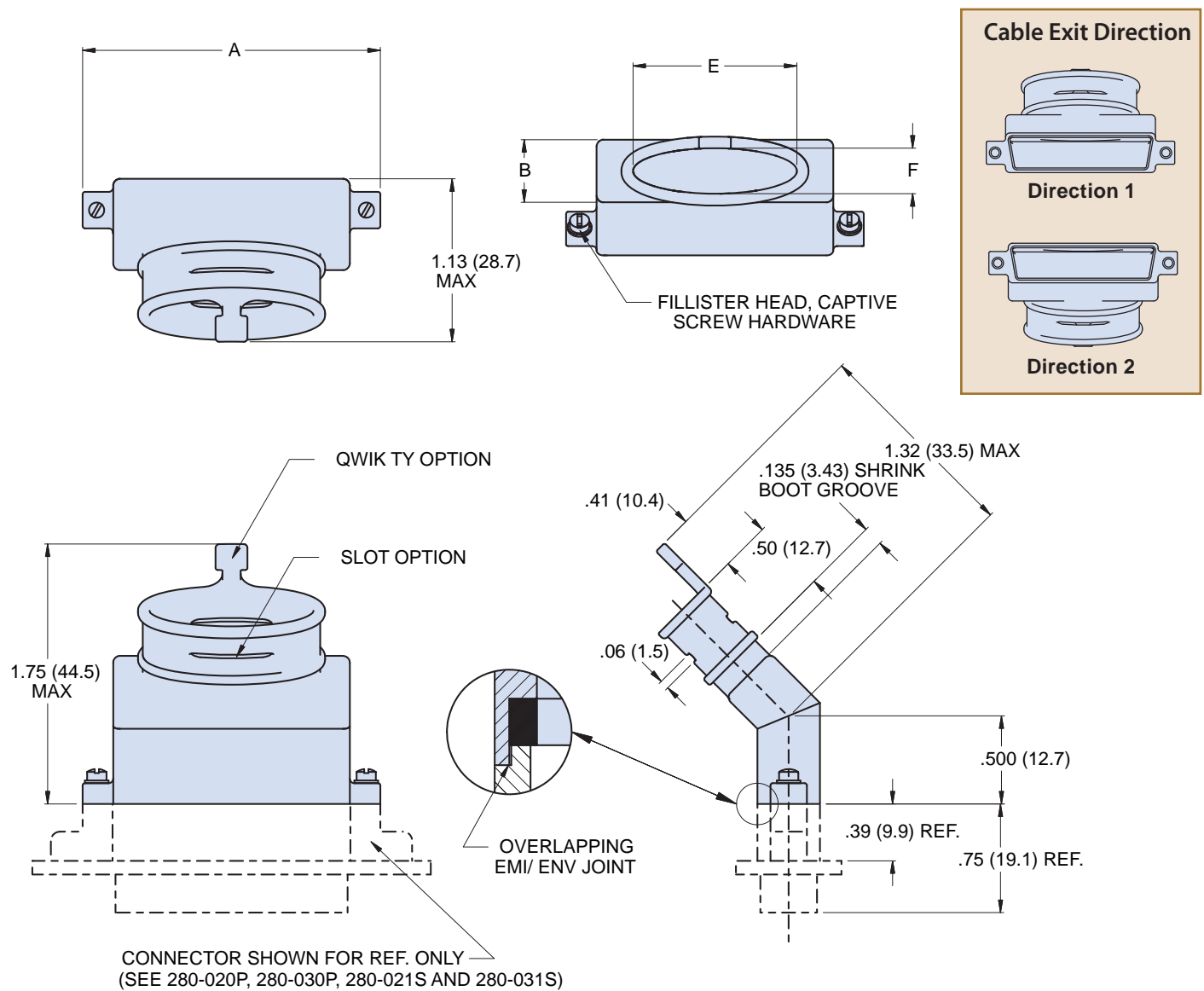
**289B007 EMI Environmental Adapter, 45° Cable Exit**



DIMENSIONS																				
Shell Size	SIZE A				SIZE B				SIZE C				SIZE D							
	A Max in.	A Max mm	B Max in.	B Max mm	E in.	F in.	E mm	F mm	E in.	F in.	E mm	F mm	E in.	F in.	E mm	F mm				
1	1.244	31.60	.511	12.98	.143	3.63	.143	3.63	.195	4.95	.195	4.95	.242	6.15	.242	6.15	.438	11.13	.375	9.53
2	1.572	39.39	.511	12.98	.188	4.78	.188	4.78	.256	6.50	.256	6.50	.480	12.19	.375	9.53	.688	17.48	.375	9.53
3	2.112	53.64	.511	12.98	.245	6.22	.245	6.22	.550	13.97	.375	9.53	.780	19.81	.375	9.53	1.125	28.58	.375	9.53
4	2.760	70.10	.511	12.98	.291	7.39	.291	7.39	.800	20.32	.375	9.53	1.260	32.00	.375	9.53	1.813	46.05	.375	9.53
5	2.666	67.71	.615	15.62	.326	8.28	.326	8.28	.770	19.56	.485	12.32	1.250	31.75	.485	12.32	1.750	44.45	.485	12.32
6	2.760	70.10	.630	17.27	.376	9.55	.376	9.55	.863	21.92	.550	13.97	1.323	33.60	.550	13.97	1.875	47.63	.550	13.97

Dimensions in inches (millimeters) and are subject to change without notice.  
 CAGE Code 06324

Printed in U.S.A.

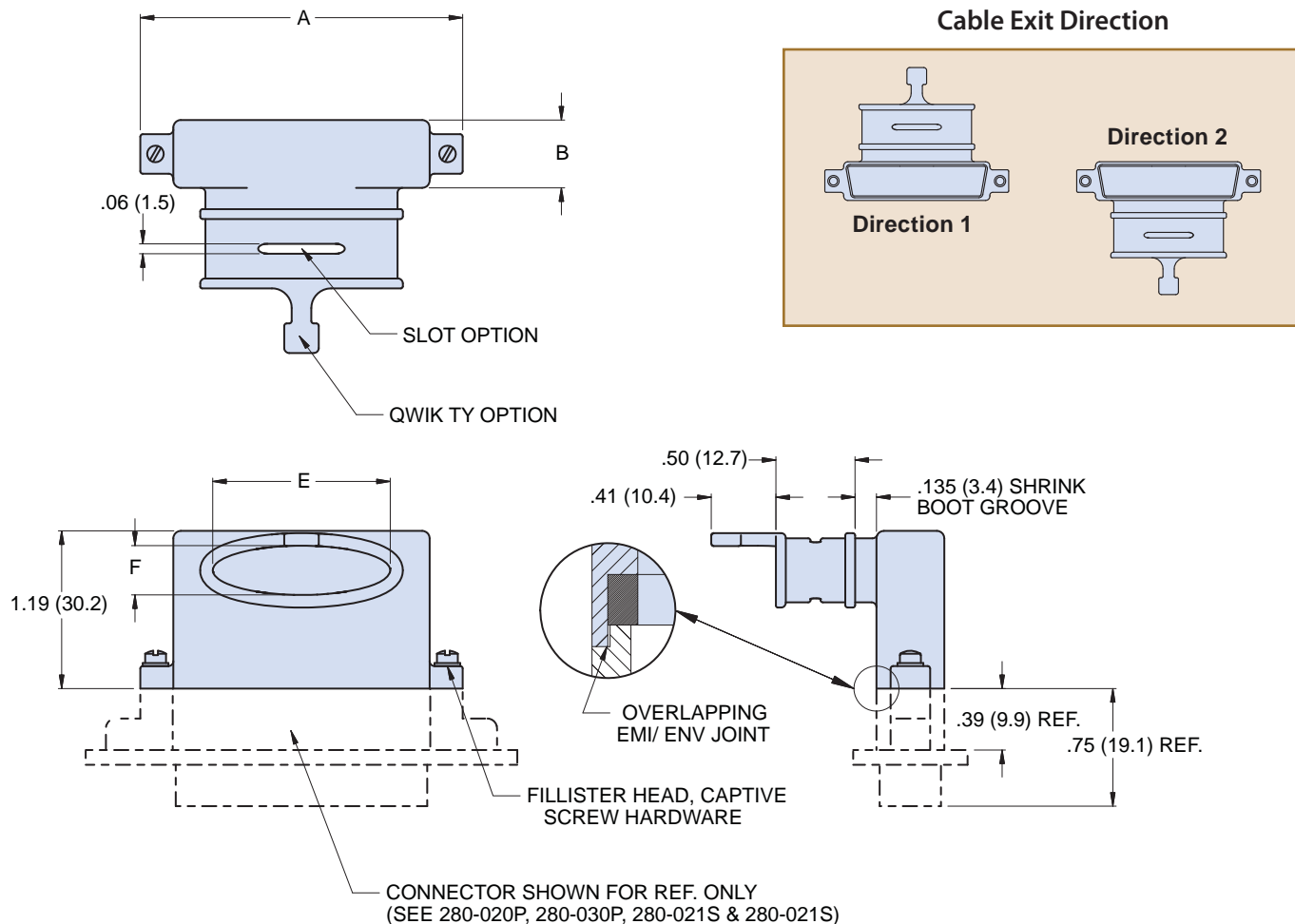
**289S007 EMI Environmental Adapter, Side Cable Exit**

**DIMENSIONS**

Shell Size	A Max		B Max		SIZE A				SIZE B				SIZE C				SIZE D			
	in.	mm	in.	mm	E	F	E	F	E	F	E	F	E	F	E	F	E	F		
1	1.244	31.60	.511	12.98	.143	3.63	.143	3.63	.195	4.95	.195	4.95	.242	6.15	.242	6.15	.438	11.13	.375	9.53
2	1.572	39.39	.511	12.98	.188	4.78	.188	4.78	.256	6.50	.256	6.50	.480	12.19	.375	9.53	.688	17.48	.375	9.53
3	2.112	53.64	.511	12.98	.245	6.22	.245	6.22	.550	13.97	.375	9.53	.780	19.81	.375	9.53	1.125	28.58	.375	9.53
4	2.760	70.10	.511	12.98	.291	7.39	.291	7.39	.800	20.32	.375	9.53	1.260	32.00	.375	9.53	1.813	46.05	.375	9.53
5	2.666	67.71	.615	15.62	.326	8.28	.326	8.28	.770	19.56	.485	12.32	1.250	31.75	.485	12.32	1.750	44.45	.485	12.32
6	2.760	70.10	.630	17.27	.376	9.55	.376	9.55	.863	21.92	.550	13.97	1.323	33.60	.550	13.97	1.875	47.63	.550	13.97

Dimensions in inches (millimeters) and are subject to change without notice.

289-015 and 289-016  
Series 28 HiPer-D  
Jackpost Kits



**HiPer-D Jackpost Kits for Cable Connectors**

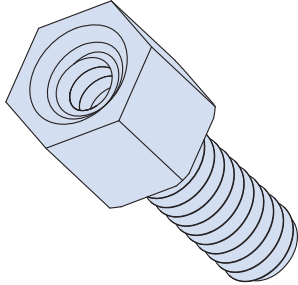

Stainless steel jackpost kits for panel mounting of HiPer-D cable connectors. 289-015 jackposts fit HiPer-D cable connectors 280-018P and 280-019S. For front-mounted and cable-mounted connectors, use 289-015-A. For rear panel mounted connectors, choose the correct jackpost based on panel thickness. #4-40 UNC 2B threads. 300 Series stainless steel, passivated. One kit consists of (2) jackposts, (2) hex nuts and (2) split lockwashers.

HIPER-D JACKPOST KITS				
Panel Thickness		Part Number	A	
in.	mm		in.	mm
(none)	(none)	<b>289-015-A</b>	.250	6.35
.031	0.79	<b>289-015-B</b>	.219	5.56
.047	1.19	<b>289-015-C</b>	.203	5.16
.062	1.57	<b>289-015-D</b>	.188	4.78
.093 <sup>(1)</sup>	2.36 <sup>(1)</sup>	<b>289-015-D</b>	.188	4.78
.125 <sup>(1)</sup>	3.18 <sup>(1)</sup>	<b>289-015-D</b>	.188	4.78

Note (1) Panels thicker than .062 (1.57) must be counterbored.

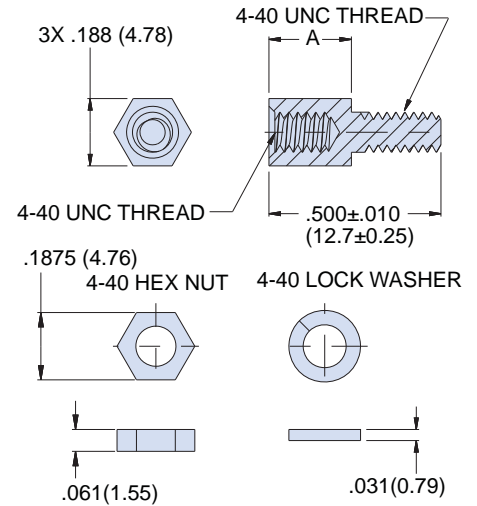

**HiPer-D Jackpost Kits for Free-Standing PCB Connectors**

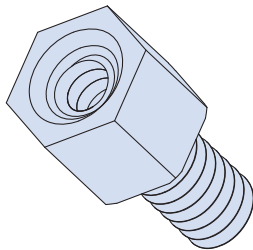

Stainless steel jackposts for panel mounting of HiPer-D freestanding PCB connectors. 289-016 jackposts fit HiPer-D cable connectors 280-026P, 280-027S, 280-028P and 280-029S. For freestanding connectors, use 289-016-A. For rear panel mounted connectors, choose the correct jackpost based on panel thickness. #4-40 UNC 2B threads. 300 Series stainless steel, passivated. One kit consists of (2) jackposts. Install into connector flange with threadlocking compound (not supplied).

HIPER-D JACKPOST KITS				
Panel Thickness		Part Number	A	
in.	mm		in.	mm
(none)	(none)	<b>289-016-A</b>	.250	6.35
.031	0.79	<b>289-016-B</b>	.219	5.56
.047	1.19	<b>289-016-C</b>	.203	5.16
.062	1.57	<b>289-016-D</b>	.188	4.78
.093 <sup>(1)</sup>	2.36 <sup>(1)</sup>	<b>289-016-D</b>	.188	4.78
.125 <sup>(1)</sup>	3.18 <sup>(1)</sup>	<b>289-016-D</b>	.188	4.78

Note (1) Panels thicker than .062 (1.57) must be counterbored.

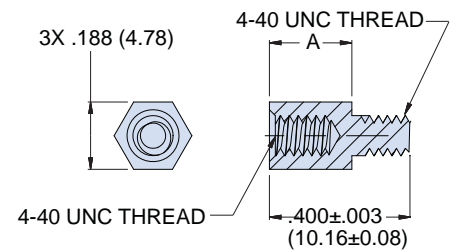

Dimensions in inches (millimeters) and are subject to change without notice.

CAGE Code 06324

Printed in U.S.A.



## PANEL CUTOUT FOR REAR-MOUNTED CONNECTORS

### Rear Mount Panel Cutout (1)

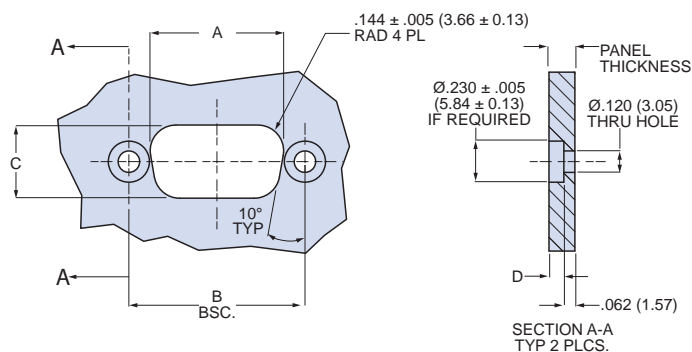

Shell Size	A		B Basic		C	
	in	mm	in	mm	in.	mm
1	.742	30.81	.984	24.99	.405	10.29
2	1.070	39.14	1.312	33.32	.405	10.29
3	1.610	53.04	1.852	47.04	.405	10.29
4	2.258	69.32	2.500	63.50	.405	10.29
5	2.155	66.93	2.406	61.11	.517	13.13
6	2.288	69.32	2.500	63.50	.579	14.71

Panel Thickness	D		Female Jackpost Part Number	
	in	mm		
No Panel	N/A	N/A	289-015-A	
.031	0.79	N/A	289-015-B	
.047	1.19	N/A	289-015-C	
.062	1.57	N/A	289-015-D	
.093	2.36	.031	0.79	289-015-D
.125	3.18	.063	1.60	289-015-D
.156	3.96	.094	2.39	289-015-D

### Application Note for Rear Panel Mounting

- (1) For rear mounting with female Jackposts, use shortened Jackposts per the table at right. For panel thickness greater than .062 (1.57), the panel must be counterbored.

## PANEL CUTOUT FOR FRONT-MOUNTED CONNECTORS 280-018P AND 280-019S

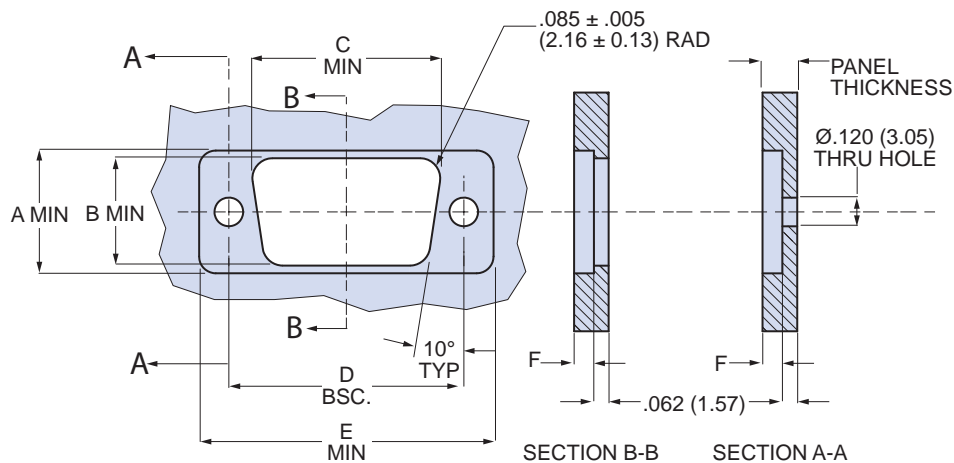

### Front Mount Panel Cutout

WHEN FRONT PANEL MOUNTING ON PANELS THICKER THAN .062 (1.57), CONNECTOR WILL SIT IN PANEL AS SHOWN

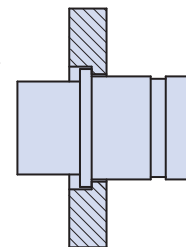

### Application Note for Front Panel Mounting

Panels thicker than .062 (1.57) should be machined as shown in order to prevent interference with mounting hardware and backshells. Front-mounted connectors are compatible with female Jackpost 289-015-A or M24308/26-1.

Shell Size	A		B		C		D Basic		E	
	in	mm	in	mm	in.	mm	in	mm	in.	mm
1	.514	13.06	.450	11.43	.787	19.99	.984	24.99	1.233	31.32
2	.514	13.06	.450	11.43	1.111	28.22	1.312	33.32	1.561	39.65
3	.514	13.06	.450	11.43	1.653	41.99	1.852	47.04	2.108	53.54
4	.514	13.06	.450	11.43	2.300	58.42	2.500	63.50	2.749	69.82
5	.625	15.88	.552	14.02	2.190	55.63	2.406	61.11	2.655	67.44
6	.688	17.48	.614	15.60	2.315	58.80	2.500	63.50	2.749	69.82

Dimensions in inches (millimeters) and are subject to change without notice.

CAGE Code 06324

Printed in U.S.A.

289-012  
Series 28 HiPer-D  
Sav-Con® D-Subminiature Connector Saver



Sav-Con® D-Subminiature Connector Saver

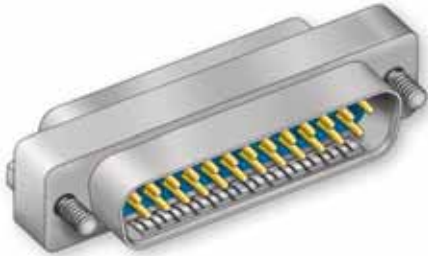

Prevent damage to expensive instruments and cables with Glenair HiPer-D Sav-Cons®. One side is a pin connector and the other side is a socket connector. Low profile one-piece machined aluminum housing and ground spring protect circuits from EMI problems. Contacts are heavy gold plated for improved durability. Available in standard density and high density contact arrangements. Contacts are factory-installed. Pin mating face has fluorosilicone rubber seal. Choose electroless nickel shell finish for avionics and space applications. Choose cadmium for compatibility with cadmium or zinc plated M24308 connectors, or choose nickel-PTFE for maximum corrosion protection. Other materials and finishes available on request.

SPECIFICATIONS

Current Rating	#22D 5 AMPS, #20 7.5 AMPS
Test Voltage	1000 VAC RMS
Insulation Resistance	5000 megohms minimum
Operating Temperature	-65° C. to +200° C.
Ingress Protection	IP 67
Shock	300 g.
Vibration, Random	43.92 g.
Magnetic Permeability	2 μ maximum
Outgassing <sup>(1)</sup>	Postcure required to meet ASTM E595 NASA requirement

STANDARD DENSITY HIPER-D SAV-CON®

No. of Contacts	Shell Size	Electroless Nickel <i>Space, Avionics (ME)</i>	Nickel-PTFE <i>Maximum Corrosion Protection (MT)</i>	Cadmium <i>General Purpose (JF)</i>
9	1	<a href="#">289-0121S9MEGR</a>	<a href="#">289-0121S9MTGR</a>	<a href="#">289-0121S9JFGR</a>
15	2	<a href="#">289-0122S15MEGR</a>	<a href="#">289-0122S15MTGR</a>	<a href="#">289-0122S15JFGR</a>
25	3	<a href="#">289-0123S25MEGR</a>	<a href="#">289-0123S25MTGR</a>	<a href="#">289-0123S25JFGR</a>
37	4	<a href="#">289-0124S37MEGR</a>	<a href="#">289-0124S37MTGR</a>	<a href="#">289-0124S37JFGR</a>
50	5	<a href="#">289-0125S50MEGR</a>	<a href="#">289-0125S50MTGR</a>	<a href="#">289-0125S50JFGR</a>

HIGH DENSITY HIPER-D SAV-CON®

No. of Contacts	Shell Size	Electroless Nickel <i>Space, Avionics (ME)</i>	Nickel-PTFE <i>Maximum Corrosion Protection (MT)</i>	Cadmium <i>General Purpose (JF)</i>
15	1	<a href="#">289-0121H15MEGR</a>	<a href="#">289-0121H15MTGR</a>	<a href="#">289-0121H15JFGR</a>
26	2	<a href="#">289-0122H26MEGR</a>	<a href="#">289-0122H26MTGR</a>	<a href="#">289-0122H26JFGR</a>
44	3	<a href="#">289-0123H44MEGR</a>	<a href="#">289-0123H44MTGR</a>	<a href="#">289-0123H44JFGR</a>
62	4	<a href="#">289-0124H62MEGR</a>	<a href="#">289-0124H62MTGR</a>	<a href="#">289-0124H62JFGR</a>
78	5	<a href="#">289-0125H78MEGR</a>	<a href="#">289-0125H78MTGR</a>	<a href="#">289-0125H78JFGR</a>
104	6	<a href="#">289-0126H104MEGR</a>	<a href="#">289-0126H104MTGR</a>	<a href="#">289-0126H104JFGR</a>

OUTGASSING NOTE

Note (1) HiPer-D Sav-Cons will not meet NASA outgassing requirements without special processing. Refer to Section B "HiPer-D Connectors for Space Flight" for additional information.

MATERIALS AND FINISHES

Shell	Aluminum alloy
Contacts	Copper alloy, 50 microinches gold plated, SST hood
insulator	Thermoset epoxy
interfacial Seal	Fluorosilicone rubber
Hardware	300 series stainless steel

STANDARD DENSITY CONTACT ARRANGEMENTS, #20 CONTACTS

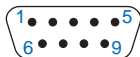

1S9  
9 #20 Contacts

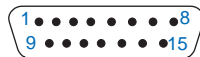

2S15  
15 #20 Contacts

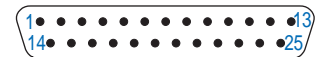

3S25  
25 #20 Contacts

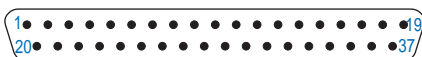

4S37  
37 #20 Contacts

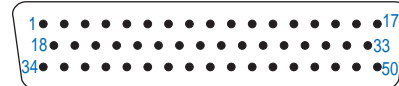

5S50  
50 #20 Contacts

Mating face of pin connector. Socket mating face is mirror image.

Dimensions in inches (millimeters) and are subject to change without notice.



289-012  
Series 28 HiPer-D  
Sav-Con® D-Subminiature Connector Saver

HIGH DENSITY CONTACT ARRANGEMENTS, #22D CONTACTS

Mating face of pin connector. Socket mating face is mirror image.

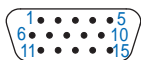

1H15  
15 #22D Contacts

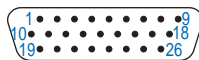

2H26  
26 #22D Contacts

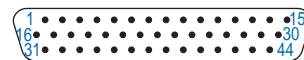

3H44  
44 #22D Contacts

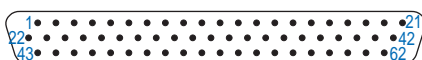

4H62  
62 #22D Contacts

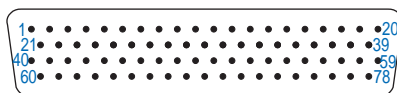

5H78  
78 #22D Contacts

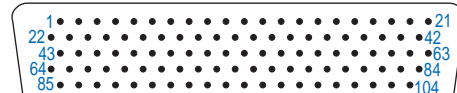

6H104  
104 #22D Contacts

289-012 DIMENSIONS

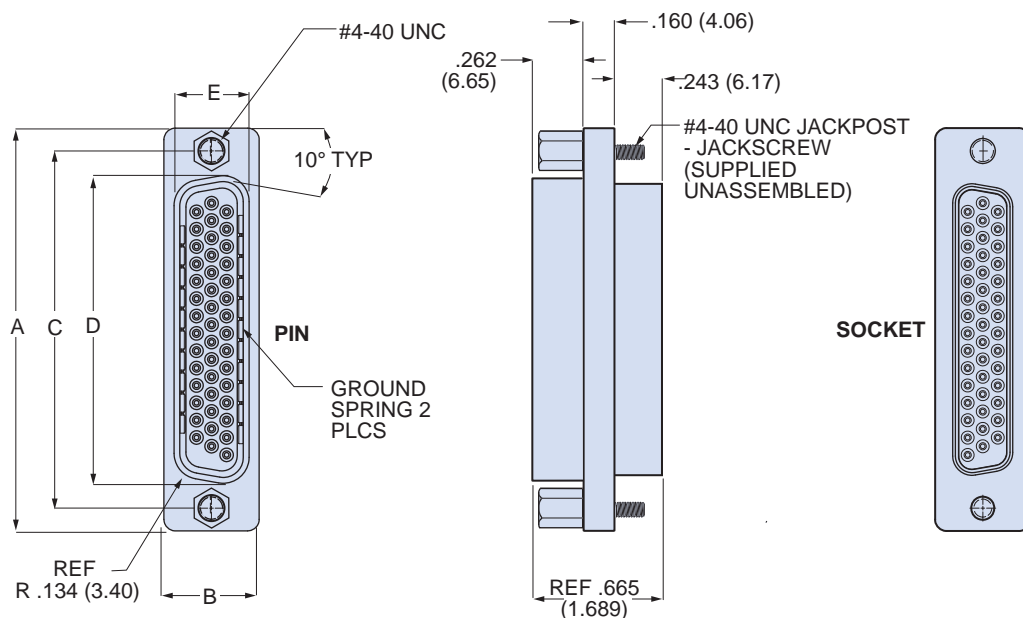

Shell Size	A		B		C Basic		D		E	
	in	mm	in	mm	in.	mm	in	mm	in	mm
1	± .015	± 0.38	± .015	± 0.38	.984	24.99	.726	18.44	.389	9.88
2	1.213	30.81	.494	12.55	1.312	33.32	1.054	26.77	.389	9.88
3	1.541	39.14	.494	12.55	1.852	47.04	1.594	40.49	.389	9.88
4	2.088	53.04	.494	12.55	2.500	63.50	2.242	56.95	.389	9.88
5	2.729	69.32	.494	12.55	2.406	61.11	2.139	54.33	.501	12.73
6	2.635	66.93	.605	15.37	2.500	63.50	2.272	57.71	.563	14.30

Dimensions in inches (millimeters) and are subject to change without notice.

CAGE Code 06324

Printed in U.S.A.

© 2011 Glenair, Inc.

GLENAIR, INC. • 1211 AIR WAY • GLENDALE, CA 91201-2497 • 818-247-6000 • FAX 818-500-9912

www.glenair.com

H-16

E-Mail: sales@glenair.com

Series 28 HiPer-D  
Part Number index



280-018P..... D-1	289-012 ..... H-15	809-015 ..... C-4
280-019S..... D-3	289-015 ..... H-13	850-002-22-360..... C-3
280-020P..... E-1	289-016 ..... H-13	850-003-22-354..... C-3
280-021S..... E-7	289-019 ..... H-1	850-021-20-368..... C-2
280-022P..... F-1	289B007..... H-9	850-022-20-369..... C-2
280-023S..... F-11	289S005..... H-3	859-012 ..... C-4
280-024P..... G-1	289S007..... H-9	859-016 ..... C-4
280-025S..... G-11	289S008..... H-6	859-017 ..... C-4
280-026P..... F-4	289T005..... H-3	859-018 ..... C-4
280-027S..... F-14	289T007..... H-9	859-019 ..... C-4
280-028P..... G-4	289T008..... H-6	859-020 ..... C-4
280-029S..... G-14	600-052 ..... C-5	859-021 ..... C-4
280-030P..... E-4	600-052-1 ..... C-5	M39029/57-354 ..... C-3
280-031S..... E-10	600-058 ..... C-5	M39029/58-360 ..... C-3
289-003 ..... H-1	600-090 ..... C-5	M39029/63-368 ..... C-2
289-004 ..... H-1	600-090-1 ..... C-5	M39029/64-369 ..... C-2

Dimensions in inches (millimeters) and are subject to change without notice.

# ALSO FROM GLENAIR: SERIES 79 **Micro-Crimp**



## Need Something Smaller Than the HiPer-D?

### ***The Micro-D with Crimp Contacts***

For new design projects not already committed to the M24308 package, Glenair offers all the same ruggedized performance in our higher-density Series 79 Micro-Crimp. The Micro-Crimp connector features crimp, rear-release size #23 contacts on tighter .075 inch (1.9 mm) spacing— as well as size #12 and #16 power and coaxial crimp

contacts in a range of hybrid layouts. Today's defense/aerospace systems require advanced levels of environmental protection, electromagnetic shielding and size/weight reduction, and the Series 79 was developed to meet these needs—especially for applications that require higher-density, smaller size and lighter weight than is provided by the venerable d-sub. Panel mounted connectors feature conductive sealing gaskets. Right angle printed circuit board connectors have an EMI shroud to prevent electromagnetic interference. Wire sealing grommets and interfacial seals protect circuits from moisture and contamination. Long story short, we've left nothing out of this our most advanced crimp-contact rectangular connector. See our website for complete order information.





# ALSO FROM GLENNAIR: SERIES 79 Micro-Crimp

## The Micro-D Connector with Crimp Contacts

### MICRO-CRIMP™

Meet the newest member of Glenair's Micro-D family, the Series 79 Micro-Crimp. The

Micro-Crimp connector features crimp, rear-release size #23 contacts on .075 inch (1.9 mm) spacing, as well as size #12 and #16 power and coaxial crimp contacts in a range of hybrid layouts. Available in 31 insert arrangements, the Micro-Crimp provides a wide selection of arrangements for data and power transmission.

Today's defense/aerospace systems require advanced levels of environmental protection, electromagnetic shielding and size/weight reduction. The Series 79 was developed to meet these needs. Panel mounted connectors feature conductive sealing gaskets. Right angle printed circuit board connectors have an EMI shroud to prevent electromagnetic interference. Wire sealing grommets and interfacial seals protect circuits from moisture and contamination. Series 79 plugs are available with auxiliary EMI springs for superior EMC performance.



Cable Plug With Socket Contacts and EMI Spring



Cable Receptacle With Pin Contacts



Panel Mount Right Angle PCB Plug with EMI Shroud and EMI Spring



Panel Mount Receptacle with Straight PC Tails

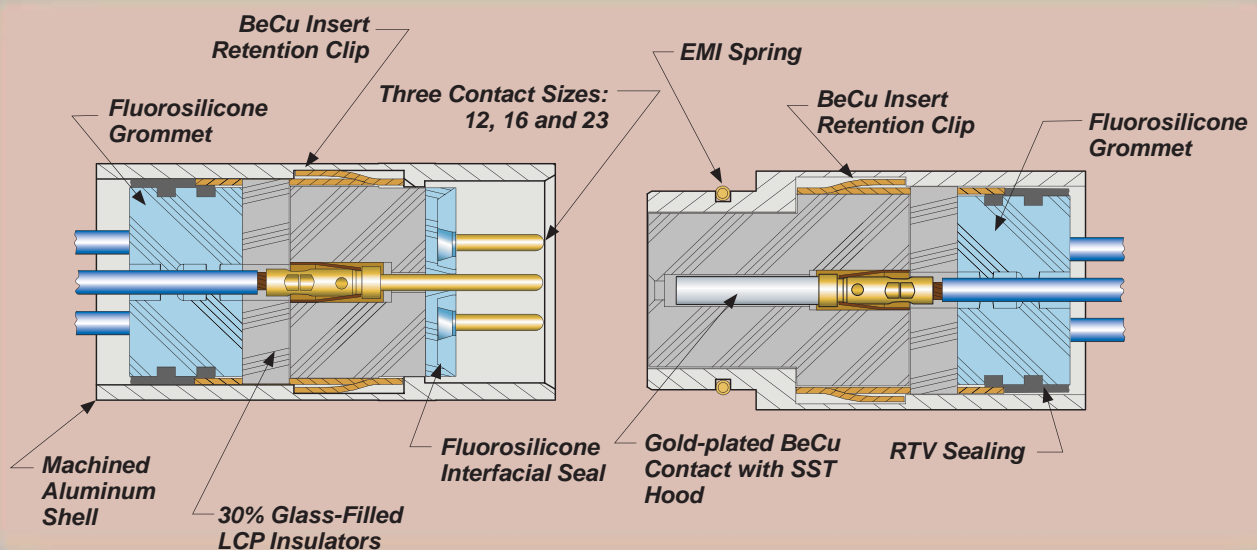



# ALSO FROM GLENAIR: SERIES 79

# Micro-Crimp

The Micro-D Connector with Crimp Contacts

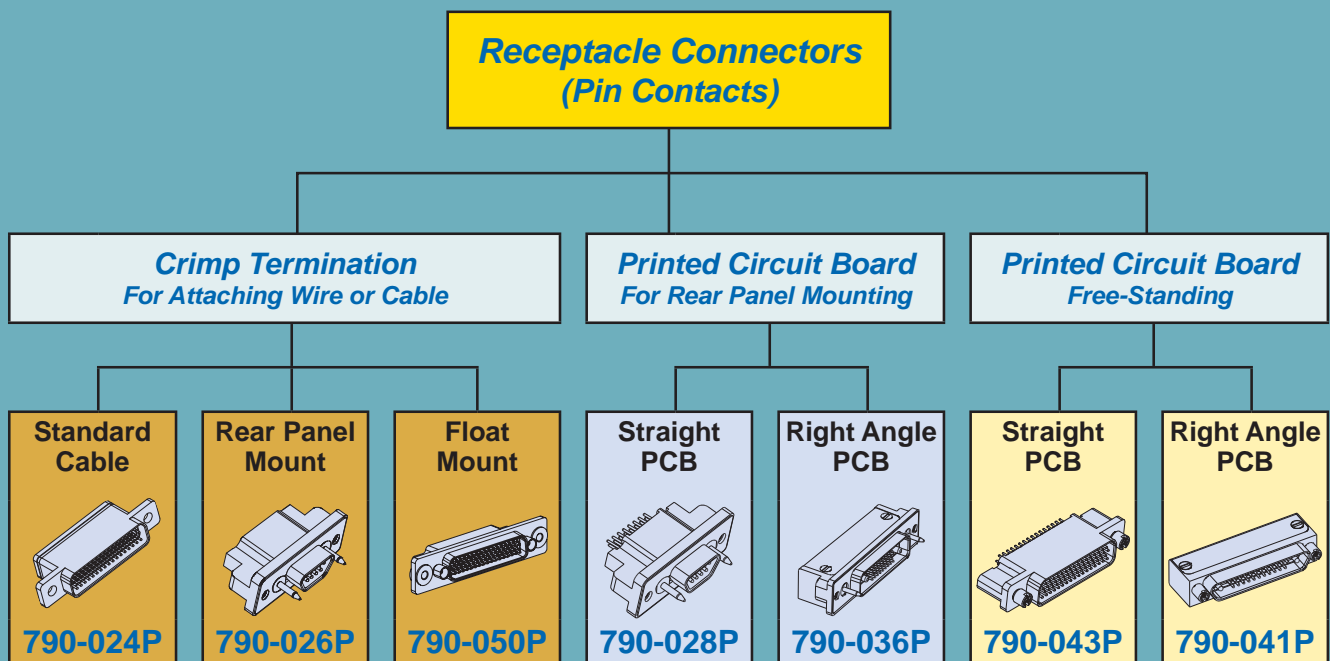
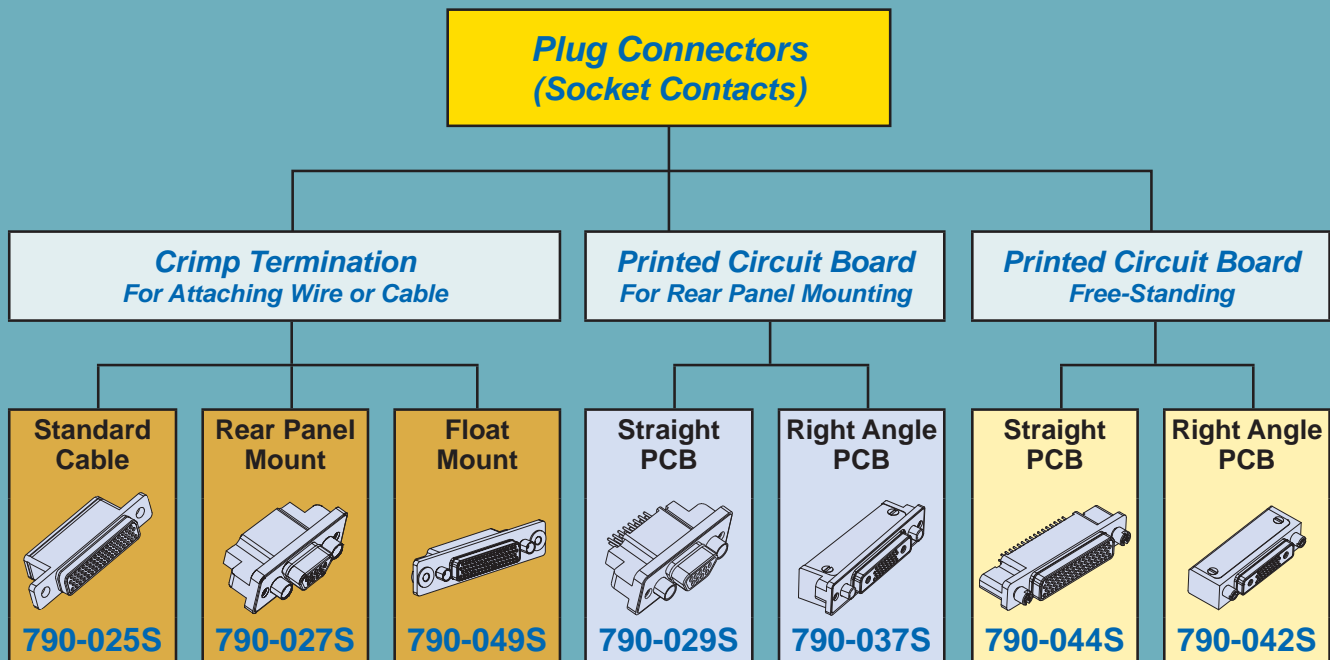

# Why CHOOSE Glenair?



Plenty of Raw Materials!



Outstanding  
Customer Service!



Abundant Machining Capacity!

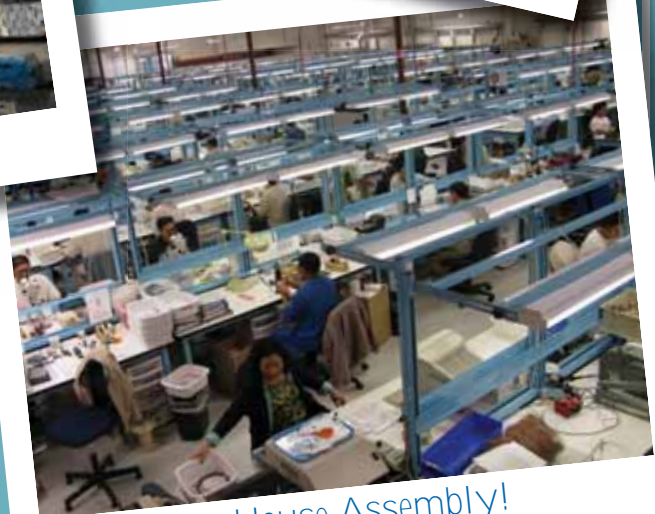

In-House Assembly!



Huge "Same-Day" Inventory!

**G**lenair®



# A World of Interconnect Solutions

## Glenair, Inc.

1211 Air Way • Glendale, California • 91201-2497  
Telephone: 818-247-6000 • Fax: 818-500-9912 • sales@glenair.com  
[www.glenair.com](http://www.glenair.com)

---

**Glenair Power Products Group**  
860 N. Main Street Extension  
Wallingford, CT 06492

Telephone: 203-741-1115  
Facsimile: 203-741-0053  
sales@glenair.com

---

**Glenair UK Ltd**  
40 Lower Oakham Way  
Oakham Business Park  
P.O. Box 37, Mansfield  
Notts, NG18 5BY England

Telephone: +44-1623-638100  
Facsimile: +44-1623-638111  
sales@glenair.co.uk

---

**Glenair Microway Systems**  
7000 North Lawndale Avenue  
Lincolnwood, IL 60712

Telephone: 847-679-8833  
Facsimile: 847-679-8849

---

**Glenair Nordic AB**  
Gustav III : S Boulevard 46  
S - 169 27 Solna  
Sweden

Telephone: +46-8-50550000  
Facsimile: +46-8-50550001  
sales@glenair.se

---

**Glenair Electric GmbH**  
Siemensstrasse 9  
D-61449 Steinbach  
Germany

Telephone: +49-6171-5905-0  
Facsimile: +49-6171-5905-90  
germany@glenair.com

---

**Glenair Iberica**  
C/ La Vega, 16  
45612 Velada  
Spain

Telephone: +34-925-89-29-88  
Facsimile: +34-925-89-29-87  
sales@glenair.es

---

**Glenair Italia S.p.A.**  
Via Cà dell'Orbo Nord, 22  
40055 Villanova di Castenaso  
Bologna, Italy

Telephone: +39-051-780098  
Facsimile: +39-051-782259  
info@glenair.it

---

**Glenair France SARL**  
7, Avenue Parmentier  
Immeuble Central Parc #2  
31200 Toulouse  
France

Telephone: +33-5-34-40-97-40  
Facsimile: +33-5-61-47-86-10  
sales@glenair.fr

