

*Out of This World*  
**INTERCONNECT SOLUTIONS**

United States ■ United Kingdom ■ Germany ■ France ■ Nordic ■ Italy ■ Spain

*Out of This World*  
**INTERCONNECT SOLUTIONS**



## TABLE OF CONTENTS

<b>Contacts, Wires and Cables</b>		<b>A</b>
<ul style="list-style-type: none"> <li>• SAE-AS39029 Crimp Contacts</li> <li>• High Performance Shielded Contacts</li> </ul>	<ul style="list-style-type: none"> <li>• Special Purpose Contacts</li> <li>• High-Speed Wire, Cable, and Flex</li> </ul>	
<b>Ultraminiature Circular Connectors and Cable Assemblies</b>		<b>B</b>
<ul style="list-style-type: none"> <li>• Series 80 Mighty Mouse Connectors</li> <li>• Series 80 <i>High-Speed</i> Mighty Mouse Connectors</li> <li>• Series 811 <i>High-Density</i> (HD) Mighty Mouse Connectors</li> </ul>	<ul style="list-style-type: none"> <li>• USB, RJ-45 and other SuperSeal™ Ethernet Connectors</li> <li>• Series 88 SuperFly™ Connectors</li> <li>• Series 15 Audio Connectors</li> </ul>	
<b>Mil-Aero Circular Connectors and Cable Assemblies</b>		<b>C</b>
<ul style="list-style-type: none"> <li>• MIL-DTL-38999 and other Environmental Connectors</li> <li>• MIL-DTL-38999 and other Hermetic Connectors</li> <li>• Series 970 PowerTrip™ Connectors</li> <li>• MIL-DTL-5015, 26482, and Industrial Power Connectors</li> </ul>	<ul style="list-style-type: none"> <li>• Series 22 Geo-Marine® Connectors</li> <li>• EMI/EMP Filter Connectors</li> <li>• MIL-DTL-28840 Connectors</li> <li>• Sav-Con® Connector Savers</li> </ul>	
<b>Rectangular Connectors and Cable Assemblies</b>		<b>D</b>
<ul style="list-style-type: none"> <li>• Series 89 MIL-DTL-32139 Nanominiature Connectors</li> <li>• MIL-DTL-83513 Micro-D Connectors</li> </ul>	<ul style="list-style-type: none"> <li>• Series 28 HiPer-D 24308 Compatible Connectors</li> <li>• Series 79 Micro-Crimp Connectors</li> </ul>	
<b>Fiber Optic Connectors, Termini and Cable Assemblies</b>		<b>E</b>
<ul style="list-style-type: none"> <li>• MIL-DTL-38999 Fiber Optic Connection System</li> <li>• GHD High Density Fiber Optic Connection System</li> <li>• Series 80 Mighty Mouse Fiber Optic Connection System</li> <li>• MIL-PRF-28876 Fiber Optic Connection System</li> </ul>	<ul style="list-style-type: none"> <li>• GFOCA M83526 Compliant Fiber Optic Connection System</li> <li>• Eye-Beam™ Expanded Beam Fiber Optics</li> <li>• Copper-to-Fiber Media Converters/Active Components</li> </ul>	
<b>Shrink Boots, Jackets and Shields</b>		<b>F</b>
<ul style="list-style-type: none"> <li>• Series 77 <i>Full Nelson</i> Environmental Shrink Boots</li> <li>• Duraelectric™, Viton™ and other Cable and Conduit Jacketing</li> <li>• AmberStrand® Lightweight Composite EMI/RFI Shielding</li> </ul>	<ul style="list-style-type: none"> <li>• ArmorLite™ Lightweight Stainless Steel EMI/RFI Shielding</li> <li>• Industry Standard EMI/RFI Metal Braided Shielding and Fabric Braided Sleeving</li> </ul>	
<b>Metal and Polymer Core Conduit Systems</b>		<b>G</b>
<ul style="list-style-type: none"> <li>• Series 72 Annular Polymer Core Conduit Systems</li> <li>• Series 74 Helical Polymer Core Conduit Systems</li> </ul>	<ul style="list-style-type: none"> <li>• Series 75 Metal-Core Conduit Systems</li> <li>• MIL-PRF-24758/Special-Purpose Conduit Systems</li> </ul>	
<b>Backshells and Other Connector Accessories</b>		<b>H</b>
<ul style="list-style-type: none"> <li>• Metal Circular and Rectangular Backshells and Accessories</li> <li>• Composite Circular and Rectangular Backshells and Accessories</li> </ul>	<ul style="list-style-type: none"> <li>• EMI/RFI CostSaver Composite Junction Boxes</li> </ul>	
<b>Interconnect Assembly Tools</b>		<b>J</b>
<ul style="list-style-type: none"> <li>• BandMaster™ ATS EMI/RFI Shield Termination System</li> </ul>	<ul style="list-style-type: none"> <li>• Backshell to Connector Assembly Tools</li> </ul>	
<b>High Reliability Cable Assemblies</b>		<b>K</b>
<ul style="list-style-type: none"> <li>• Overmolded and ASAP Cable Assemblies</li> </ul>	<ul style="list-style-type: none"> <li>• Wired Conduit Assemblies</li> </ul>	

SAE-AS39029

# HIGH PERFORMANCE CONNECTOR CONTACTS

SIGNAL • POWER • DATA • SPECIALS

Glenair brings a new perspective to the supply of high-performance Mil-Spec and commercial contacts: High Availability! Whether you need a standard duty socket for a MIL-DTL-28840 connector or an extended duty pin for MIL-DTL-38999 Series III, we have you covered with products that are always in stock—with no dollar or quantity minimums. In addition to the broadest selection and availability, Glenair also delivers outstanding interconnection compatibility. Glenair QPL SAE-AS39029 as well as our proprietary contact series are guaranteed to mate properly and perform at the upper limits of application requirements.



SAE-AS39029  
Signal Contacts



Power  
Contacts



High-Performance  
Data Contacts



Special Purpose  
Contacts



High-Speed Wire,  
Cable, and Flex





**SAE-AS39029  
Crimp Contact Selection Guide**



**A**

Military Part Number	Glenair Part Number	Contact Size	Wire Accommodation	Pin / Socket	BIN Color Striping		
					0	1	2
M39029/56-348	850-001-22-348	22	22-28 AWG	Socket	Orange	Yellow	Grey
M39029/56-351	850-001-20-351	20	20-24 AWG	Socket	Orange	Green	Brown
M39029/56-352	850-001-16-352	16	16-20 AWG	Socket	Orange	Green	Red
M39029/56-353	850-001-12-353	12	12-14 AWG	Socket	Orange	Green	Orange
M39029/56-527	850-001-10-527	10	10 AWG	Socket	Green	Red	Violet
M39029/57-354	850-003-22-354	22	22-28 AWG	Socket	Orange	Green	Yellow
M39029/57-357	850-003-20-357	20	20-24 AWG	Socket	Orange	Green	Violet
M39029/57-358	850-003-16-358	16	16-20 AWG	Socket	Orange	Green	Grey
M39029/57-359	850-003-12-359	12	12-14 AWG	Socket	Orange	Green	White
M39029/58-360	850-002-22-360	22	22-28 AWG	Pin	Orange	Blue	Black
M39029/58-363	850-002-20-363	20	20-24 AWG	Pin	Orange	Blue	Orange
M39029/58-364	850-002-16-364	16	16-20 AWG	Pin	Orange	Blue	Yellow
M39029/58-365	850-002-12-365	12	12-14 AWG	Pin	Orange	Blue	Green
M39029/58-528	850-002-10-528	10	10 AWG	Pin	Green	Red	Grey
M39029/63-368	850-021-20-368	20	20-24 AWG	Socket	Orange	Blue	Grey
M39029/64-369	850-022-20-369	20	20-24 AWG	Pin	Orange	Blue	White

BIN Color Coding									
0 BLACK	1 BROWN	2 RED	3 ORANGE	4 YELLOW	5 GREEN	6 BLUE	7 VIOLET	8 GREY	9 WHITE

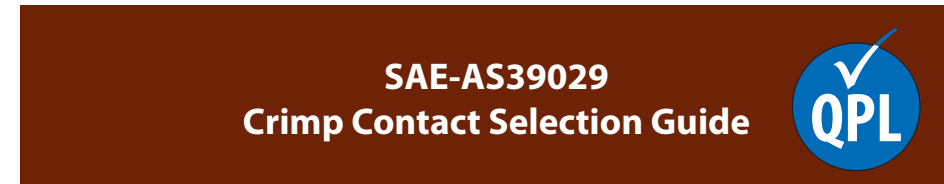

**A**

Military Part Number	Glenair Part Number	Contact Size	Wire Accommodation	Pin / Socket	BIN Color Striping		
					0	1	2
M39029/83-450	850-004-20-450	20	22-26 AWG	Pin	Yellow	Green	Black
M39029/83-451	850-004-20-451	20	28-32 AWG	Pin	Yellow	Green	Brown
M39029/83-508	850-004-20-508	20	20-24 AWG	Pin	Green	Black	Grey
M39029/84-452	850-005-20-452	20	22-26 AWG	Socket	Yellow	Green	Red
M39029/84-453	850-005-20-453	20	28-32 AWG	Socket	Yellow	Green	Orange
M39029/84-509	850-005-20-509	20	20-24 AWG	Socket	Green	Black	White
M39029/106-614	850-006-22-614	22	22-28 AWG	Socket	Blue	Brown	Yellow
M39029/106-615	850-006-20-615	20	20-24 AWG	Socket	Blue	Brown	Green
M39029/106-616	850-006-16-616	16	16-20 AWG	Socket	Blue	Brown	Blue
M39029/106-617	850-006-12-617	12	12-14 AWG	Socket	Blue	Brown	Violet
M39029/106-618	850-006-10-618	10	10 AWG	Socket	Blue	Brown	Grey
M39029/107-620	850-007-22-620	22	22-28 AWG	Pin	Blue	Red	Black
M39029/107-621	850-007-20-621	20	20-24 AWG	Pin	Blue	Black	Brown
M39029/107-622	850-007-16-622	16	16-20 AWG	Pin	Blue	Red	Red
M39029/107-623	850-007-12-623	12	12-14 AWG	Pin	Blue	Red	Orange
M39029/107-624	850-007-10-624	10	10 AWG	Pin	Blue	Red	Yellow

BIN Color Coding									
0 BLACK	1 BROWN	2 RED	3 ORANGE	4 YELLOW	5 GREEN	6 BLUE	7 VIOLET	8 GREY	9 WHITE



## High-Performance Shielded Contacts Selection Guide



A

Military Part Number	Glenair Part Number	Contact Size	Pin / Socket	Type	BIN Color Striping		
					0	1	2
M39029/27-210	852-001-12-210	12	Socket	Coaxial	Red	Brown	Black
M39029/27-402	852-001-12-402	12	Socket	Coaxial	Yellow	Black	Red
M39029/27-403	852-001-12-403	12	Socket	Coaxial	Yellow	Black	Orange
M39029/27-404	852-001-12-404	12	Socket	Coaxial	Yellow	Black	Yellow
M39029/27-405	852-001-12-405	12	Socket	Coaxial	Yellow	Black	Green
M39029/27-406	852-001-12-406	12	Socket	Coaxial	Yellow	Black	Blue
M39029/27-407	852-001-12-407	12	Socket	Coaxial	Yellow	Black	Violet
M39029/27-408	852-001-12-408	12	Socket	Coaxial	Yellow	Black	Gray
M39029/28-211	852-002-12-211	12	Pin	Coaxial	Red	Brown	Brown
M39029/28-409	852-002-12-409	12	Pin	Coaxial	Yellow	Black	White
M39029/28-410	852-002-12-410	12	Pin	Coaxial	Yellow	Brown	Black
M39029/28-411	852-002-12-411	12	Pin	Coaxial	Yellow	Brown	Brown
M39029/28-412	852-002-12-412	12	Pin	Coaxial	Yellow	Brown	Red
M39029/28-413	852-002-12-413	12	Pin	Coaxial	Yellow	Brown	Orange
M39029/28-414	852-002-12-414	12	Pin	Coaxial	Yellow	Brown	Yellow
M39029/28-415	852-002-12-415	12	Pin	Coaxial	Yellow	Brown	Green
M39029/59-366	852-006-08-366	08	Socket	Coaxial	Orange	Blue	Blue
M39029/60-367	852-007-08-367	08	Pin	Coaxial	Orange	Blue	Violet
M39029/75-416	852-003-12-416	12	Socket	Coaxial	Yellow	Brown	Blue
M39029/75-417	852-003-12-417	12	Socket	Coaxial	Yellow	Brown	Violet
M39029/75-418	852-003-12-418	12	Socket	Coaxial	Yellow	Brown	Gray
M39029/75-419	852-003-12-419	12	Socket	Coaxial	Yellow	Brown	White
M39029/75-420	852-003-12-420	12	Socket	Coaxial	Yellow	Red	Black
M39029/75-421	852-003-12-421	12	Socket	Coaxial	Yellow	Red	Brown
M39029/75-422	852-003-12-422	12	Socket	Coaxial	Yellow	Red	Red
M39029/75-423	852-003-12-423	12	Socket	Coaxial	Yellow	Red	Orange
M39029/76-424	852-008-16-424	16	Pin	Coaxial	Yellow	Red	Yellow
M39029/76-425	852-008-16-425	16	Pin	Coaxial	Yellow	Red	Green

BIN Color Coding									
0 BLACK	1 BROWN	2 RED	3 ORANGE	4 YELLOW	5 GREEN	6 BLUE	7 VIOLET	8 GREY	9 WHITE

## High-Performance Shielded Contacts Selection Guide



A

Military Part Number	Glenair Part Number	Contact Size	Pin / Socket	Type	BIN Color Striping		
					0	1	2
M39029/76-426	852-008-16-426	16	Pin	Coaxial	Yellow	Red	Blue
M39029/76-427	852-008-16-427	16	Pin	Coaxial	Yellow	Red	Violet
M39029/77-428	852-009-16-428	16	Socket	Coaxial	Yellow	Red	Gray
M39029/77-429	852-009-16-429	16	Socket	Coaxial	Yellow	Red	White
M39029/77-430	852-009-16-430	16	Socket	Coaxial	Yellow	Orange	Black
M39029/77-431	852-009-16-431	16	Socket	Coaxial	Yellow	Orange	Brown
M39029/78-432	852-010-16-432	16	Socket	Coaxial	Yellow	Orange	Red
M39029/78-433	852-010-16-433	16	Socket	Coaxial	Yellow	Orange	Orange
M39029/78-434	852-010-16-434	16	Socket	Coaxial	Yellow	Orange	Yellow
M39029/78-435	852-010-16-435	16	Socket	Coaxial	Yellow	Orange	Green
M39029/90-529	853-001-08-529	8	Pin	Concentric Twinax	Green	Red	White
M39029/91-530	853-002-08-530	8	Socket	Concentric Twinax	Green	Orange	Black
M39029/102-558	852-004-12-558	12	Pin	Coaxial	Green	Green	Gray
M39029/103-559	852-005-12-559	12	Socket	Coaxial	Green	Green	White
M39029/113-625	853-003-08-625	8	Pin	Concentric Twinax	Blue	Red	Green
M39029/113-626	853-003-08-626	8	Pin	Concentric Twinax	Blue	Red	Blue
M39029/114-628	853-004-08-628	8	Socket	Concentric Twinax	Blue	Red	Gray
M39029/114-629	853-004-08-629	8	Socket	Concentric Twinax	Blue	Red	White
N/A	854-001-01	8	Pin	Quadrx	N/A		
N/A	854-001-02	8	Pin	Quadrx	N/A		
N/A	854-001-03	8	Pin	Quadrx	N/A		
N/A	854-001-04	8	Pin	Quadrx	N/A		
N/A	854-001-05	8	Pin	Quadrx	N/A		
N/A	854-002-01	8	Socket	Quadrx	N/A		
N/A	854-002-02	8	Socket	Quadrx	N/A		
N/A	854-002-03	8	Socket	Quadrx	N/A		
N/A	854-002-04	8	Socket	Quadrx	N/A		
N/A	854-002-05	8	Socket	Quadrx	N/A		

BIN Color Coding									
0 BLACK	1 BROWN	2 RED	3 ORANGE	4 YELLOW	5 GREEN	6 BLUE	7 VIOLET	8 GREY	9 WHITE



## Special Purpose Contacts Selected Examples

### Size #12 Differential Twinax Contacts for Multi-Gigabit Data Rate Applications

Glenair Part No.	Cable	Impedance	Frequency Range	VSWR	Insertion Loss
Socket = 853-015-01 Pin = 853-016-01	859-041 963-001	100-Ohms Nominal	DC to 10 GHz	1.1 + (.03 * F GHz)	1.3 *F GHz



### 050-301 Size #8 Contact Cavity Optoelectronic Insert Transmitter and Receiver

- ARINC 664, 801, 803, 804, and 818 standard compliant
- Data rates from 125Mbps to 3.8 Gbps for transmitter, 125Mbps to 4.25Gbps for receiver
- Supports fast and Gigabit Ethernet, AFDX, 1x/2x Fibre Channel, DVI, HDMI, SFPDP, Serial Rapid I/O (sRIO).
- ARINC 801 1.25mm/2.5mm ceramic fiber ferrule, or expanded beam



### Thermocouple Contacts to Fit D38999 Series I, II, III and IV Connectors



Glenair Part No.	Military Part No.	AWG Wire Size
Pin = 850-023	Pin = AS39029/87	16-28
Series I, III, IV Socket = 850-024	Series I, III, IV Socket = AS39029/88	
Series II Socket = 850-025	Series II Socket = AS39029/89	
Custom PCB and crimp termination thermocouples available in type K, E, J, N and more.		

### Wire-to-Contact Expansion and Reducer Adapters

Glenair Part No.	Finish	Wire Accommodation	Contact Wire Barrel Size
687-348	Z2 - Gold Plate Z3 - Silver Plate	6, 8, 10, 12, 14, 16, 18, 20, 22, 24, 0-4	4, 8, 12, 16, 20, 22
859-015	Z4 - Tin Plate	10, 12, 14, 16, 18, 20, 22, 24, 26, 28	10, 12, 16, 20, 22



### PCB Contacts to Fit MIL-DTL-38999/20 and /24 Rear-Release Connectors

Mating End Size	Glenair Part Number
22	850-010-22
20	850-010-20
16	850-010-16
12	850-010-12

Mating End Size	Glenair Part Number
22	850-011-22
20	850-011-20
16	850-011-16
12	850-011-12



## Special Purpose Contacts Selected Examples

### High-Power and LouverBand Contacts



High-Power Contacts		
Contact Cavity Size	Wire Accommodation	Glenair Part Number
8	8 AWG	850-013 (Socket) 850-014 (Pin)



High ampacity LouverBand contacts for use in Glenair Series 970 PowerTrip™  
850-026 (pin) 850-027 (skt)

### High-Pressure Assemblies for Pure Gas Pneumatic/Hydraulic Applications

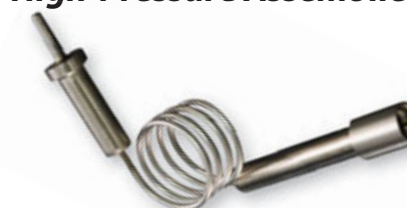

831-001 #12 Gas Tube Assembly for MIL-DTL-38999 Series I, III, and IV



D38999 Ser. I, III, IV

### Size #12 Pneumatic Contacts



Contact Type	For Use In	Part Number
Socket	Series 79	857-010
Socket	D38999 Type	857-050



Contact Type	For Use In	Part Number
Pin	Series 79	857-011
Pin	D38999 Type	857-057

### Grommet Sealing Plugs

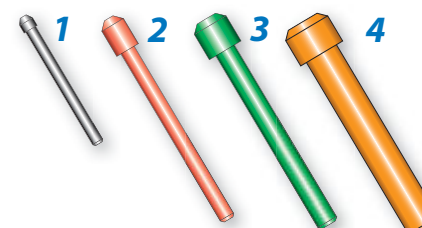
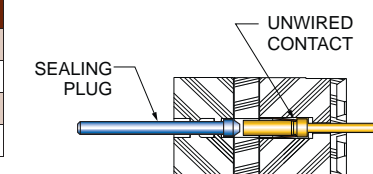

Fig.	Size	Color	Part Number	Military Part Number
1	#23	Black	809-155	(None)
2	#20	Red	859-012	MS27488-20-2
3	#16	Green	859-013	MS27488-16-2
4	#12	Orange	859-014	MS27488-12-2

All sizes available and in Same-Day stock. Consult factory for more information.



### Crimp Tool And Positioner For #12, #16 and #20 Power Contacts, Crimp Adapters



**1** Crimp tool for use with size #20, #16 and #12 power pins. 9.75 inches OAL, 1.25 pounds. Use with M39029/57 and /58 contacts and 809-093 adapters.

**2** Positioner for use with 809-093 adapters.

**3** Positioner for use with size #20, #12 and #16 Power contacts.

Glenair offers a complete line of crimp tools in Same-Day stock.

Figure	Part Number	Military Part Number	Daniels Part Number
1	809-136	M22520/1-01	AF8
2	809-137	M22520/1-04	TH163
3	809-138	(none)	TH653



## High-Speed Wire, Cable, and Flex

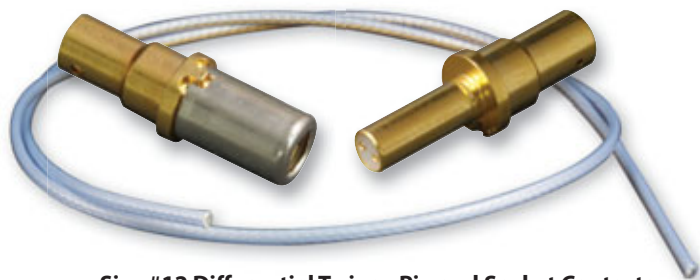

Size #12 Differential Twinax Pin and Socket Contacts and High-Speed Differential Pair Cable

- One-stop shopping for general-purpose and specialty high-speed wire, cable and contacts
- No minimum orders. Glenair wire and contact part numbers are in stock and ready for immediate, same-day shipment
- All major high-speed cable protocols supported
- Custom marking available

**High availability, high-speed cables and contacts for digital and RF applications—No minimum orders or minimum cable runs**

Size #12 Differential Twinax Cable and Printed Circuit Board Contacts and Compatible Cables							
Type	Glenair Part No.	AWG Wire Size	Cable Accommodation	Impedance	Frequency Range	VSWR	Insertion Loss
Socket	853-015-01	28	963-001	100-Ohms Nominal	DC to 10 GHz	1.1 + (.03 * F GHz)	1.3 *F GHz
Pin	853-016-01	28	963-001	100-Ohms Nominal	DC to 10 GHz	1.1 + (.03 * F GHz)	1.3 *F GHz
Socket	853-020	N/A	PC Mount	100-Ohms Nominal	DC to 10 GHz	1.1 + (.03 * F GHz)	1.3 *F GHz
Pin	853-021	N/A	PC Mount	100-Ohms Nominal	DC to 10 GHz	1.1 + (.03 * F GHz)	1.3 *F GHz

High-Performance Coaxial Contacts and Compatible Cables			
Connector	Contact Size	Cable	Glenair Part #
38999 I, III, IV	8 Pin	962-004	852-060-285
38999 I, III, IV	8 Socket	962-004	852-061-285
38999 I, III, IV	8 Pin	962-003	852-060-141
38999 I, III, IV	8 Socket	962-003	852-061-141
38999 I, III, IV	12 Pin	962-002	852-062
38999 I, III, IV	12 Socket	962-002	852-063
38999 I, III, IV	16 Pin	962-002	852-064
38999 I, III, IV	16 Socket	962-002	852-065
38999 II	16 Socket	962-002	852-066
38999 I, III, IV	20 Pin	962-001	852-067
38999 I, III, IV	20 Socket	962-001	852-068
HiPer-D/24308	20HD Pin	962-001	852-069
HiPer-D/24308	20HD Socket	962-001	852-070
Mighty Mouse	20HD Pin	962-001	852-038
Mighty Mouse	20HD Socket	962-001	852-039

Contact the factory for preterminated coaxial cordsets



Matched impedance Coax contacts available in sizes ranging from #20 to #8



Quadrax contacts available for D38999 Series I, II, III and IV type connectors, Series 28 HiPer-D and Series 80 Mighty Mouse

## High-Speed Wire, Cable, and Flex



General-Purpose High-Speed Wire and Cable					
Cable Protocol	100BASE-T	100BASE-T	Impedance Matched Ribbon	100 Ω Shielded Twisted Pair	100 Ω Shielded Twisted Pair
Glenair Part Number	963-008	963-009	963-007	963-010	963-011
Construction	unshielded twisted pair	Quad	Ribbon	shielded twisted pair	shielded twisted pair
Number of Pairs	2	-	10 to 64	2	4
Number of Conductors	4	4	-	4	8
Conductor AWG	24	24	28	26	26
Impedance	100 ± 10 Ω	100 ± 10 Ω	-	100 ± 10 Ω	100 ± 10 Ω
Capacitance (pF/ft.)	13	13	-	13	13
Velocity of Propagation	80%	80%	-	80%	80%

Protocol-Specific High-Speed Cable						
Cable Protocol	1000BASE-T (Cat 5e)	10GBASE-T (Cat 6a)	IEEE 1394	USB 2.0	USB 3.0	SATA
Glenair Part Number	963-002	963-003	963-006	963-005	963-012	963-013
Construction	unshielded twisted pair	shielded twisted pair	Quad	shielded twisted pair	3 pairs, 2 power	2 foiled twisted pairs
Number of Pairs	4	4	-	1	3	2
Number of Conductors	8	8	4	4	10	8
Conductor AWG	24	24	24	variable	variable	26 signal; 28 drain
Impedance	100 ± 10 Ω	100 ± 10 Ω	110 ± 7 Ω	90 ± 13 Ω	90 ± 7 Ω	100 ± 10 Ω
Capacitance (pF/ft.)	14.5	14.5	12.5	13	-	-
Velocity of Propagation	70%	70%	80%	70%	-	-

High-Speed Coaxial Cable				
Cable Protocol	Temp Flex 047	Temp Flex 086	Temp Flex 141	Harbour LL-285
Glenair Part Number	962-001	962-002	962-003	962-004
Construction	coaxial	coaxial	coaxial	coaxial
Number of Conductors	1	1	1	1
Overall Shield Dia.	.047	.086	.141	.285
Impedance	50 ± 1 Ω	50 ± 1 Ω	50 ± 1 Ω	50 ± 2 Ω
Capacitance (pF/ft.)	29	29	29	24.5
Velocity of Propagation	70%	70%	70%	84%

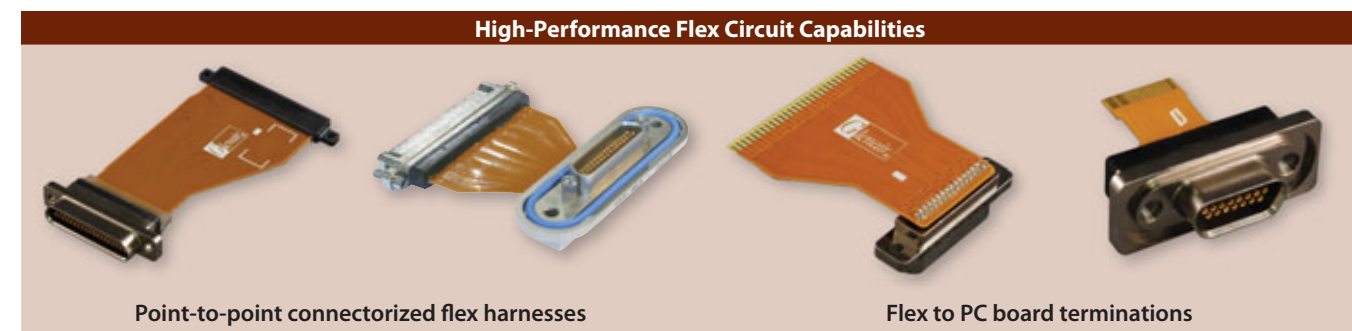

**HIGH-PERFORMANCE**

# ULTRAMINIATURE CIRCULAR CONNECTORS

SAVE WEIGHT • SAVE SPACE • ENHANCE PERFORMANCE

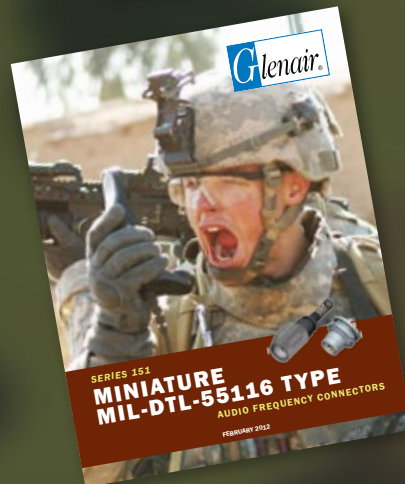

Glenair designs and manufactures the world's broadest and deepest selection of ultraminiature circular connectors for tactical field applications. Our Series 80 Mighty Mouse has become a new industry standard and is now used in countless high-performance interconnect applications. The Series 88 SuperFly™ is our next-generation nanominiature package for tactical field applications.



Series 80 Mighty Mouse (Left)  
Compared to D38999 (Right)



Series 80 High Speed  
Mighty Mouse



Series 81  
High Density  
Mighty Mouse



USB, RJ-45 and other  
SuperSeal™ Ethernet/Network  
Connectors



Series 88 SuperFly™  
Ultraminiature Cordsets



Series 15  
Audio Connectors







## Series 80 Mighty Mouse Connectors and Cables

Size and weight comparison of Series 801 Mighty Mouse (7 Contacts)...



...to MIL-DTL-38999 (6 Contacts)  
Up to 71% weight savings and 52% size savings

**MICRO-CRIMP™**

Rectangular versions of the Mighty Mouse (Series 79 Micro-Crimp) are also available, see page D-8

- Over 50 tooled LCP contact arrangements ranging from 1 – 130 contacts
- MIL-DTL-38999 caliber environmental, mechanical, and electrical performance
- Ultraminiature #23 contacts set on .076 centers
- Size #20HD, #16, #12, signal, power, fiber optic, coaxial and pneumatic layouts
- Discrete connectors and turnkey cable assemblies

## The new industry standard for high-performance, ultraminiature connectors

Introducing the new Mighty Mouse Series 824 Locking Push-Pull Connector: All the familiar size, weight and performance advantages of the industry-standard Mighty Mouse with revolutionary low-profile locking push pull mating. Finally, mil-spec caliber performance comes to locking push-pull applications.

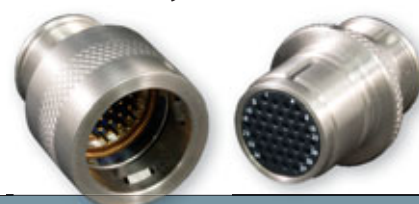

Series 800	Series 801	Series 802	Series 803	Series 804	Series 805
Light-Duty UNF Thread	Rugged Double-Start ACME Thread	3500 PSI AquaMouse	Fast-Mate Bayonet Coupling	Quick-Disconnect Push-Pull	Ratcheted Triple-Start

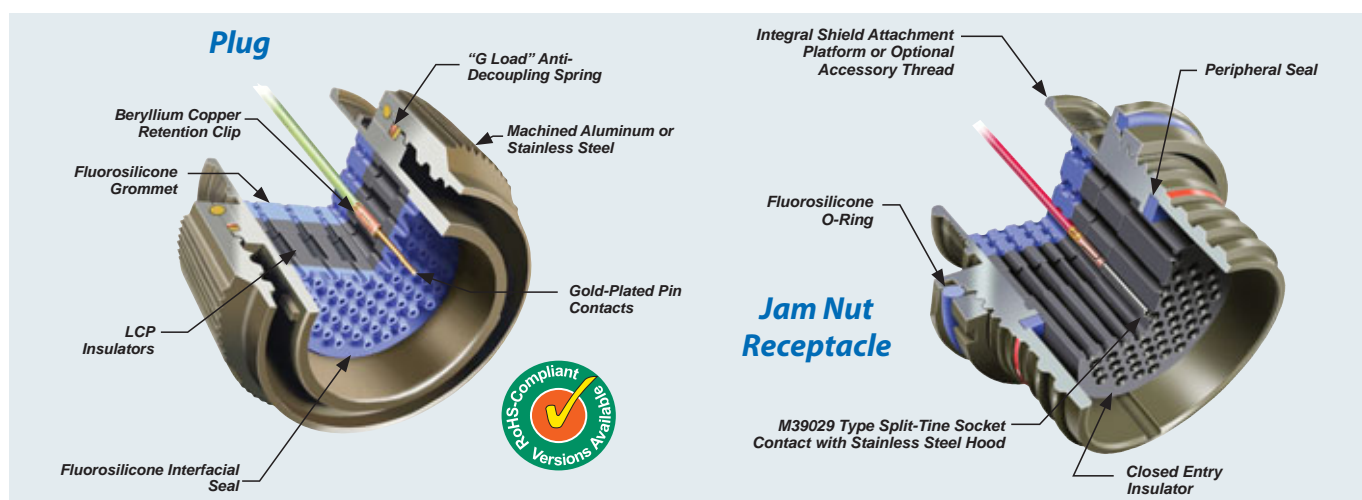

## Series 80 Mighty Mouse Connectors and Cables

### Series 80 Mighty Mouse Contact Arrangements

Contact Size	Contact Quantity					Contact Arrangement						
	#23	#20	#20HD	#16	#12	Series 800	Series 801	Series 802	Series 803	Series 804	Series 805	
Size #23 Contacts 5 Amp Max. Current 500 VAC #22-#28 AWG	3					5-3	5-3	5-3	5-3	5-3	Not Avail.	
	4					6-4	6-4	6-4	6-4	6-4	8-4	
	6					6-6	6-6	6-6	6-6	6-6	8-6	
	7					6-7	6-7	6-7	6-7	6-7	8-7	
	10					7-10	7-10	7-10	7-10	7-10	9-10	
	13					8-13	8-13	8-13	8-13	8-13	10-13	
	19					9-19	9-19	9-19	9-19	9-19	11-19	
	26					10-26	10-26	10-26	10-26	10-26	12-26	
	37					12-37	13-37	12-37	12-37	12-37	15-37	
	55					Not Avail.	16-55	14-55	14-55	14-55	18-55	
85					Not Avail.	17-85	15-85	Not Avail.	Not Avail.	19-85		
130					Not Avail.	21-130	21-130	Not Avail.	Not Avail.	23-130		
Size #20HD Contacts 7.5 Amp Max. Current 750 VAC #20-#24 AWG			3			6-23	6-23	6-23	6-23	6-23	8-23	
			5			7-25	7-25	7-25	7-25	7-25	9-25	
			8			8-28	8-28	8-28	8-28	8-28	10-28	
			10			9-210	9-210	9-210	9-210	9-210	11-210	
			20			12-220	13-220	12-220	12-220	12-220	15-220	
			35			Not Avail.	16-235	14-235	14-235	14-235	18-235	
			41			Not Avail.	17-241	15-241	Not Avail.	Not Avail.	19-241	
Size #16 Contacts 13 Amp Max. Current 1800 VAC #16-#20 AWG				1		6-1	6-1	6-1	6-1	6-1	8-1	
				2		8-2	8-2	8-2	8-2	8-2	10-2	
				4		9-4	9-4	9-4	9-4	9-4	11-4	
				5		10-5	10-5	10-5	10-5	10-5	12-5	
	Size #16 Coaxial Contacts 50-75 Ohms				7		12-7	13-7	12-7	12-7	12-7	15-7
					12		Not Avail.	16-12	14-12	14-12	14-12	18-12
				14		Not Avail.	17-14	15-14	Not Avail.	Not Avail.	19-14	
Size #12 Contacts 23 Amp Max. Current 1800 VAC #12-#14 AWG					22	Not Avail.	21-22	21-22	Not Avail.	Not Avail.	23-22	
				1		7-1	7-1	7-1	7-1	7-1	9-1	
				2		10-2	10-2	10-2	10-2	10-2	12-2	
				2		12-2	13-2	12-2	12-2	12-2	15-2	
Size #12 Differential Twinax Contacts 100-Ohms				3		12-3	13-3	12-3	12-3	12-3	15-3	
				5		Not Avail.	16-5	14-5	14-5	14-5	18-5	
				7		Not Avail.	17-7	15-7	Not Avail.	Not Avail.	19-7	
Contact Arrangements with Mixed Size (Combo) Layouts	4	2				8-200	8-200	8-200	8-200	8-200	10-200	
	8	2				9-201	9-201	9-201	9-201	9-201	11-201	
	4			2		9-200	9-200	9-200	9-200	9-200	11-200	
	8			2		10-202	10-202	10-202	10-202	10-202	12-202	
	4				2	10-201	10-201	10-201	10-201	10-201	12-201	
	6				2	12-200	13-200	12-200	12-200	12-200	15-200	
	10				2	12-201	13-201	12-201	12-201	12-201	15-201	
	12				1	10-200	10-200	10-200	10-200	10-200	12-200	

### New Mighty Mouse #8 Contact Arrangements (Quadrax, Coax, Twinax and Power)

Series 801		8-1	16-2	17-3	19-4	21-5
Series 805		10-1	18-2	19-3	21-4	23-5



**Series 80 High Speed Mighty Mouse Connectors and Cables**  
Featuring DuPont™ Teflon® PFA Insulators



Next-Generation Series 80 Mighty Mouse High Speed Connectors with DuPont™ Teflon® PFA Insulators

- Same size and weight savings as original LCP insulator versions with superior performance in 2, 3, and 4-pair differential applications
- Crimp rear-release contacts
- Environmentally sealed
- Integral band platform
- Supplied with size #23 gold-plated copper alloy crimp PCB or solder cup contacts

**100-Ohm high-speed, high-bandwidth, ultraminiature connectors and cables for eSATA and USB 3.0 applications**

Rated Performance Supported Protocols					
Protocol	Utilized Pin Count	Cabling Spec	Bandwidth	Data Rate	Cable Construction
USB 2.0	4	90-Ohm	400 MHz	418 MB/s	1 Data Pair, 1 Power Pair
eSATA	7	100-Ohm	up to 4.5 GHz	3 GB/s	2 Data Pairs
USB 3.0	9	90-Ohm	up to 7.5 GHz	5 GB/s	3 Data Pairs, 1 Power Pair

Contact Arrangements Mating Face View of Pin Connector (Socket Connector Numbers are Reversed)		
<b>6 - 4</b>	<b>6 - 7</b>	<b>7 - 10</b>
Shell Size 6 4 Size #23 Contacts	Shell Size 6 7 Size #23 Contacts	Shell Size 7 10 Size #23 Contacts

Specifications	
Current Rating	5 AMPS
Dielectric Withstanding Voltage	500 VAC RMS
Insulation Resistance	5000 megohms minimum
Operating Temperature	-65° C. to +150° C.
Shock	300 g.
Vibration	37 g.
Shielding Effectiveness	55 dB minimum from 100MHz to 1000MHz.
Durability	2000 mating cycles

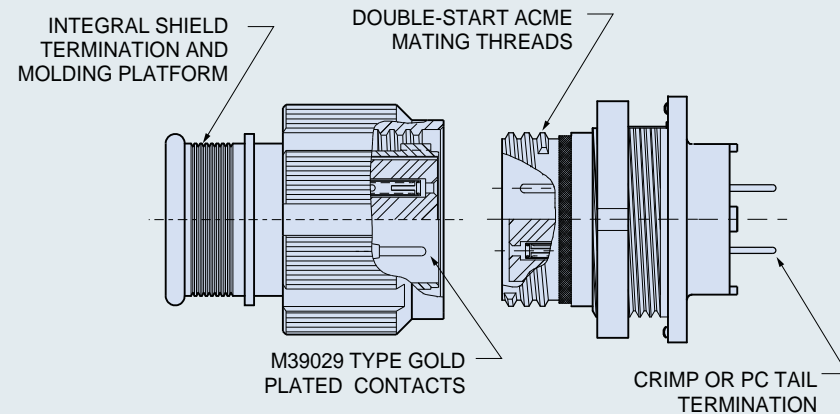

**Series 80 High Speed Mighty Mouse Connectors and Cables**  
Featuring DuPont™ Teflon® PFA Insulators

Table illustrates the relationship between contact and wire density and bandwidth performance in miniaturized interconnect applications. As contact density increases the relative performance of the interconnect, measured in bandwidth, improves. Note the position of the Series 80 High-Speed Mighty Mouse compared to standard Mighty Mouse.



The Series 80 High-Speed Mighty Mouse is available as discrete components or in factory-terminated overmolded high speed differential cordsets

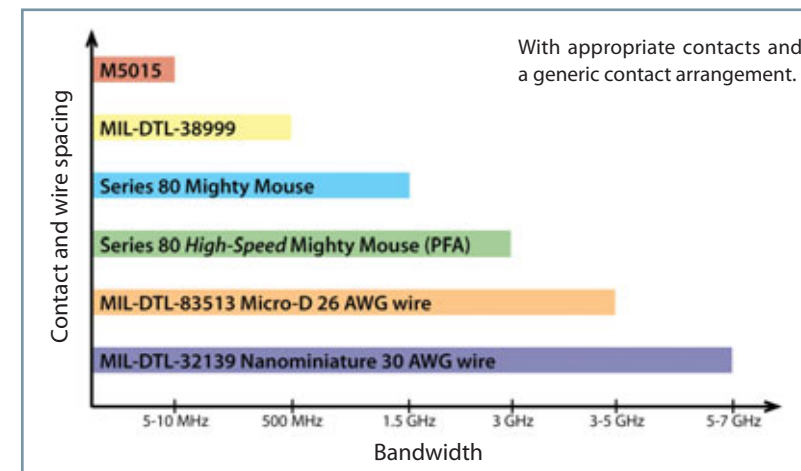

With Grommet Removed High Speed Performance	
Impedance	100 Ω ±7 Ω at 100-Picosecond
VSWR	<1.4 up to 4-GHz
Insertion Loss	
1 GHz	.51 dB
2 GHz	.53 dB
3 GHz	.57 dB
4 GHz	1.2 dB
5 GHz	1.25 dB

With Grommet Intact High Speed Performance	
Impedance	100 Ω ±15 Ω at 100-Picosecond
VSWR	<1.5 up to 3-GHz
Insertion Loss	
1 GHz	.73 dB
2 GHz	.76 dB
3 GHz	.85 dB

In order to achieve high speed performance, this connector must be mated to another high speed Mighty Mouse connector.

**Need something faster?**

Size #12 Differential Twinax Contacts may be specified in standard Mighty Mouse connectors for multi-gigabit data rate applications



Series 963-001 Cable Construction Details	
Conductor	28 AWG Silver Plated High Strength Copper Alloy
Insulation	Extruded Foamed Fluoropolymer Color: Blue and White
Inner Shield	Aluminum/Polyester Tape, 100% Coverage
Outer Shield	Round Silver Plated Copper Braid, 90% Coverage
Jacket	Extruded FEP Color: Transparent Blue

Series 963-001 Cable Properties	
Impedance	100 ± 10 Ohms
Capacitance	12.0 pF/Ft (Nom)
V.O.P.	80%
Attenuation	0.25 dB/m @ 100 MHz 0.75 dB/m @ 500 MHz 1.25 dB/m @ 1000 MHz
Temperature Rating	150° C

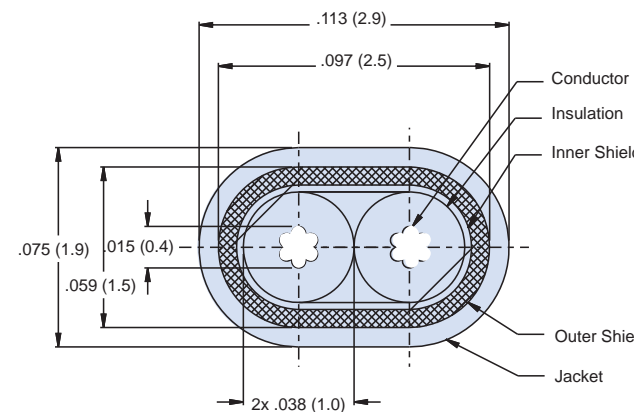

**Cross-section of Glenair high-performance series 859-041 100 Ohm differential parallel pair cable. For SATA applications Glenair recommends our 801-045 cordsets with two parallel pairs of the special wire terminated to four #23 AWG contacts.**



## Series 811 Mighty Mouse High Density (HD) Connectors and Cables



**811-001-06ME9-42SA**  
Series 811 Plug



**811-003-07ME9-42PA**  
Series 811 Receptacle

- High Density Micro TwistPin Contacts set on .050 centers deliver over twice the density of standard Series 80 Mighty Mouse
- 7 to 42 Contacts
- Water Resistant to 1 meter
- Double-start ACME threaded coupling

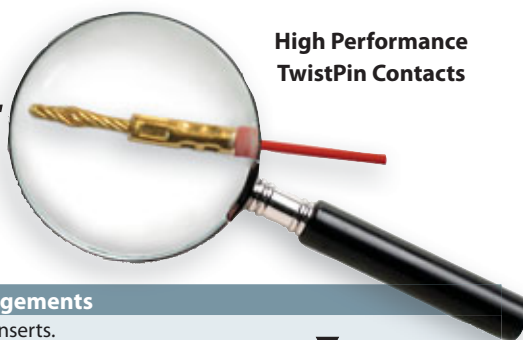

High Performance  
TwistPin Contacts

**Mighty Mouse high density connector delivers size and weight savings and outstanding performance**

### Series 811 Mighty Mouse HD Contact Arrangements

Pin insert shown, use reverse order for socket inserts.

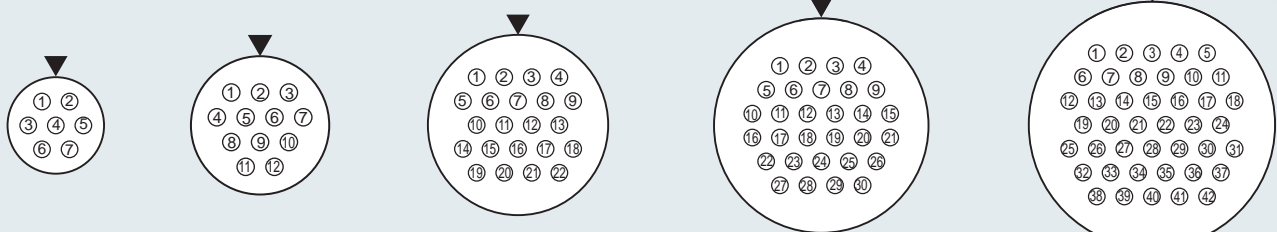

5-7 7 Contacts    6-12 12 Contacts    7-22 22 Contacts    8-30 30 Contacts    9-42 42 Contacts

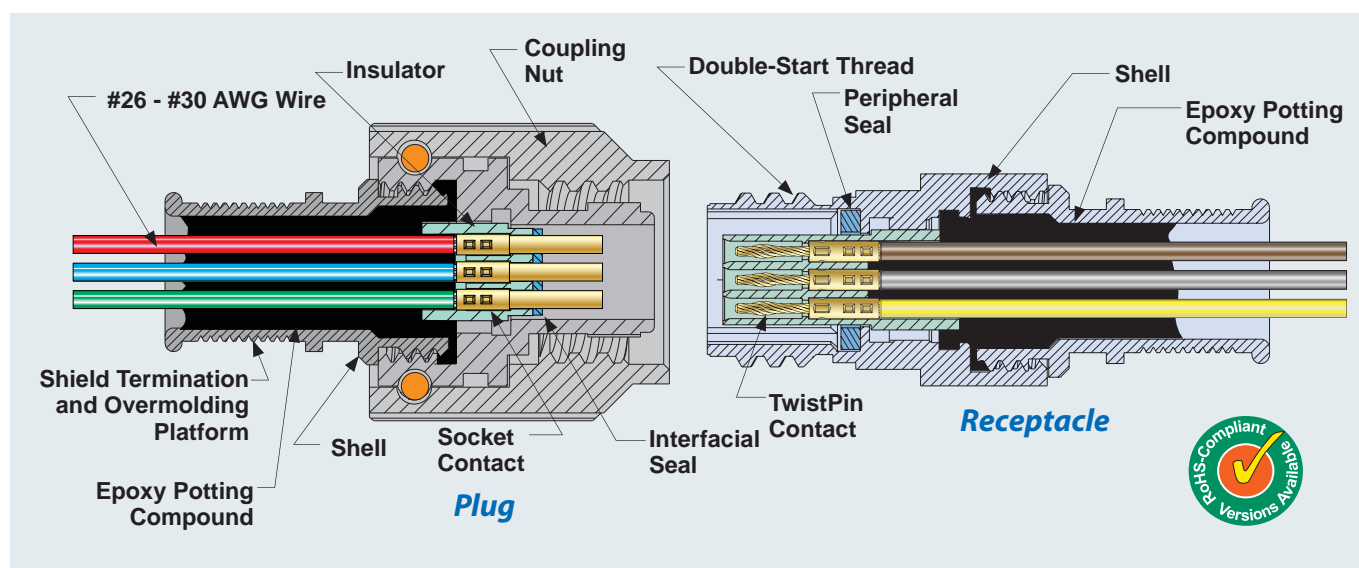

## Series 811 Mighty Mouse High Density (HD) Connectors and Cables



### The 811 HD Difference: Micro TwistPin Contacts

Widely used for radars, missiles, avionics, and space vehicles, the Micro TwistPin is a spring pin composed of helically wound strands of copper alloy wire, welded into a bundle, then "bulged" and crimped to a copper alloy sleeve. These gold over nickel plated pins and sockets offer low, stable contact resistance even when subjected to temperature extremes and vibration. Designers of soldier systems and other military electronics, medical and high-end industrial equipment have all turned to the TwistPin contact in order to reduce the size and weight of high-performance systems.

### TwistPin Contact



TwistPin



Socket

### Available Protective Covers



Series 667-347  
and 667-218



Series 809-190  
and 809-191

Specifications	
Current Rating	3 AMPS
Dielectric Withstanding Voltage	600 VAC sea level, 150 VAC at 70,000 ft.
Insulation Resistance	5000 megohms minimum
Operating Temperature	-65° C. to +150° C.
Contact Resistance	8 milliohms maximum
Water Immersion, Mated	MIL-STD-810G, Method 512.5 1 meter for 1 hour
Water Ingress, Mated	Ingress protection 67
Shock	300 g's (MIL-DTL-38999 para. 4.5.21.1)
Vibration, Sine	60 g's (MIL-DTL-38999 para. 4.5.23.2.1)
Vibration, Random	23 g's (MIL-DTL-38999 para. 4.4.23.1)
Altitude-Low Temperature	EIA-364-105
Durability	2000 cycles of mating
Magnetic Permeability	2 μ maximum
Shielding Effectiveness	55 dB minimum from 100MHz to 1000MHz.

### Series 811 Mighty Mouse HD Connector Selector





USB, RJ-45 and other  
SuperSeal™ Ethernet Connectors



**Crimp contact micro-USB connectors with outstanding environmental performance and EMI/RFI grounding**

Mighty Mouse USB Electrical Specs - Plug and Receptacle	
IEC Compatibility (EN61000-4)	
61000-4-2 (ESD): Air Gap And HBM - 15kV, Contact - 8kV	
Bi-Directional Configuration	
Ultra Low Leakage Current	

- Significant size and weight reduction compared to MIL-DTL-38999 type USB/RJ-45 solutions
- Rear-release crimp contact termination as well as USB/RJ-45 jumper accommodation
- Superior sealing, IP67, in unmated condition compared to other available environmental circulars
- Superior grounding for electrostatic discharge and EMC
- Superior cable shield termination with integrated banding platform
- Optional spring-loaded protective covers for environmental protection of junction boxes and switches
- Wide range of high speed Ethernet/network protocols supported, including USB 2.0, USB 3.0, and RJ-45
- High-capacity, high-speed memory sticks

Test Description	Mighty Mouse USB Performance Requirements/Specifications	Procedure Per MIL-DTL-38999 or Other Standard
Dielectric withstanding voltage	Maximum leakage current = 2 milliamperes No evidence of electric breakdown or flashover	4.5.11.1 or 4.5.11.2 IAW EIA-364-20, Method A
Insulation resistance	At ambient temperature: >5000 megohms between any pair of contacts and between any contact and the shell. after altitude immersion = 1000 megohms min. after humidity = 100 megohms min. At elevated temperature: >1000 megohms	4.5.10.1 and 4.5.10.2 IAW EIA-364-21
Contact resistance	Terminal-to-terminal resistance of mated connector contacts shall not exceed 0.050 ohms.	4.5.14
Mating durability	500-1000 cycles depending on plating, with no mechanical damage. Dielectric, contact resistance and air pressure requirements as described above shall be met after 500-1000 mating cycles.	4.5.8
Contact retention	Individual contacts capable of withstanding at least 10 pounds axial load applied uniformly at one pound per second.	IAW EIA-364-29
Vibration and Shock	37 g's random vibration, 300 g's shock. No electrical discontinuity, no disengagement of mated connectors, backing off of the coupling mechanism, or evidence of cracking, breaking, or loosening.	4.5.23
Temperature cycling	-65°C to 175°C or 200°, depending on finish. No blistering, peeling or separation of plating or other damage detrimental to the operation of the connector.	4.5.4 EIA364-32, Test cond. A
Salt spray	5% solution, 34°-36°C. 48-1000 hours, depending on finish. Unmated connectors show no lifting of plated coating or exposure of basis material under 3X magnification which adversely affects performance.	4.5.13 EIA-364-26
Humidity	Cycle wired, mated connectors between 25 °C at 80 % and 65 °C at 50 %. Ramp time = 0.5 hour, dwell = 1.0 hour. 24 cycles.	4.5.26 EIA364-31, Method IV
Water immersion	1 Meter for 1 Hour, mated.	MIL-STD-810 Method 512
EMI Shielding	Series 801: Good • Series 804: Very Good • Series 805: Excellent	4.5.28 EIA-364-66



USB, RJ-45 and other  
SuperSeal™ Ethernet Connectors

SuperSeal™ Mighty Mouse Micro-B USB Connector Selector



Other SuperSeal™ Ethernet/network connector series available from Glenair, include MIL-DTL-38999 type solutions as well as ruggedized, reverse-bayonet MIL-DTL-5015s





Series 88 SuperFly™ Ultraminiature Cordsets



Threaded Plug



Threaded Receptacle



B

The ultimate high-performance cordset: ready for the toughest (and smallest!) applications you've got

Glennair Series 88 SuperFly™ Cordsets represent a perfect storm of high-performance contacts, shells, wires, termination and mating technologies. SuperFly™ is the only connector series in existence that combines the weight-saving and performance advantages of nanominiature, microminiature and AS39029 type (size #23) contacts in a precision package made to order for battlefield and other high-performance applications. Available only in cordsets and single-ended pigtails, each SuperFly assembly ships with ultra-flexible, high-speed GhostWire™ cabling, your choice of threaded or quick disconnect coupling and a wide-range of contact arrangements from 3–44 contacts.



SuperFly™ is supplied from the factory only as pre-terminated pigtails or cordsets

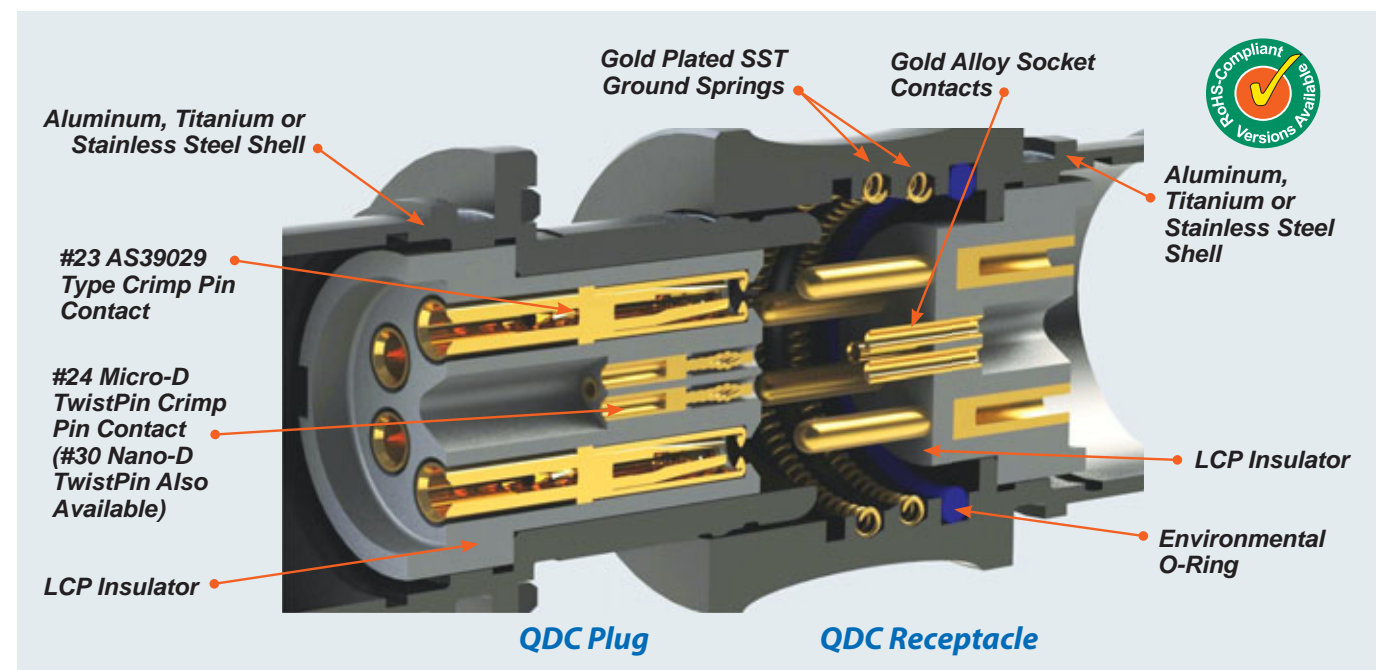

Series 88 SuperFly™ Ultraminiature Cordsets

Push-pull version with high/low force release option



Threaded version for secure mating

B

SuperFly™ Ultraminiature Cordset Key Features

- 1–5 AMP Current Rating
- Performance-Optimized Contact Spacing
- Accepts #22 to #32 AWG Wire
- Panel-Mount and PCB Versions
- First Mate/Last Break Power Contacts
- Hybrid Contact System
- Push-Pull or Threaded Coupling
- Overmolded and Fabric Braided Cordsets
- Available Fiber Optic Termini
- Robust EMI Shielding

Supported Contacts



#23 AS39029 Type 5 Amp Crimp Contact



#24 Micro-D 3 Amp TwistPin Contact



#30 Nano-D 1 Amp TwistPin Contact

Contact Arrangements

SuperFly™ Contact Configurations				
Size #23 Contacts	E-3W	G-7W	H-10W	
Micro Twist Pin	D-3M	G-10M	K-19M	L-22M
Nano Twist Pin	B-7N	C-10N	E-19N	F-22N
	H-37N	J-44N		
Micro Hybrid Configurations	C-2M2N	E-4M4N	K-13M19N	
Size #23 Hybrid Configurations	D-2W2N	F-4W4N	H-6W14N	J-7W19N

SuperFly™ Layouts and Protocols	
Layout	Protocol(s)
B-7N	eSATA/SATA
C-10N	USB 3.0 (low power) Ethernet
C-2M2N	USB
D-3M	
D-2W2N	USB
E-3W	
E-19N	HDMI
E-4M4N	Ethernet PoE
F-22N	HDMI (3 extra) DisplayPort (2 extra)
F-4W4N	Ethernet PoE
G-7W	eSATA/SATA
G-10M	USB 3.0 Ethernet (2 extra)
H-10W	USB 3.0 Ethernet (2 extra)
H-37N	
H-6W14N	HDMI (3 extra)
J-44N	
J-7W19N	HDMI (7 extra) Camera Link
K-19M	HDMI
K-13M19N	HDMI (13 extra)
L-22M	HDMI (3 extra) DisplayPort (2 extra)



Series 15 Audio Connectors  
Series CB Pogo Pin



Series CB Cable Plug      Series CB Jam Nut Receptacle

- Qualified to VG95351 (seven pole) and VG96934 (ten pole)
- Ultraminiature version of U.S. standard 55116 audio frequency connectors
- Robust environmental, mechanical and EMI performance
- High durability—5000 mating cycles



CB 10 Pin (left) Compared to MIL-DTL-55116 6 Pin Connector

**The compact audio frequency bayonet connector with spring-loaded contacts—VG qualified!**

CB Series Specifications	
Current rating	2.5 Amps per contact maximum
Voltage rating (DWV)	500 VAC
Insulation resistance	5000 MΩ
Durability	5000 cycles of mating, minimum
Contact resistance	5 mΩ
Water ingress protection	IP68
Water immersion	2 meters, 48 hours
Air pressure	0.4 bar
Operating temperature	-55° C to +85° C
Shielding effectiveness	50 dB attenuation up to 100 MHz
Corrosion resistance (salt spray)	48 hours
Maximum wire size	1mm maximum diameter



Turnkey Cordsets

Self-Cleaning "Wiping" Contacts

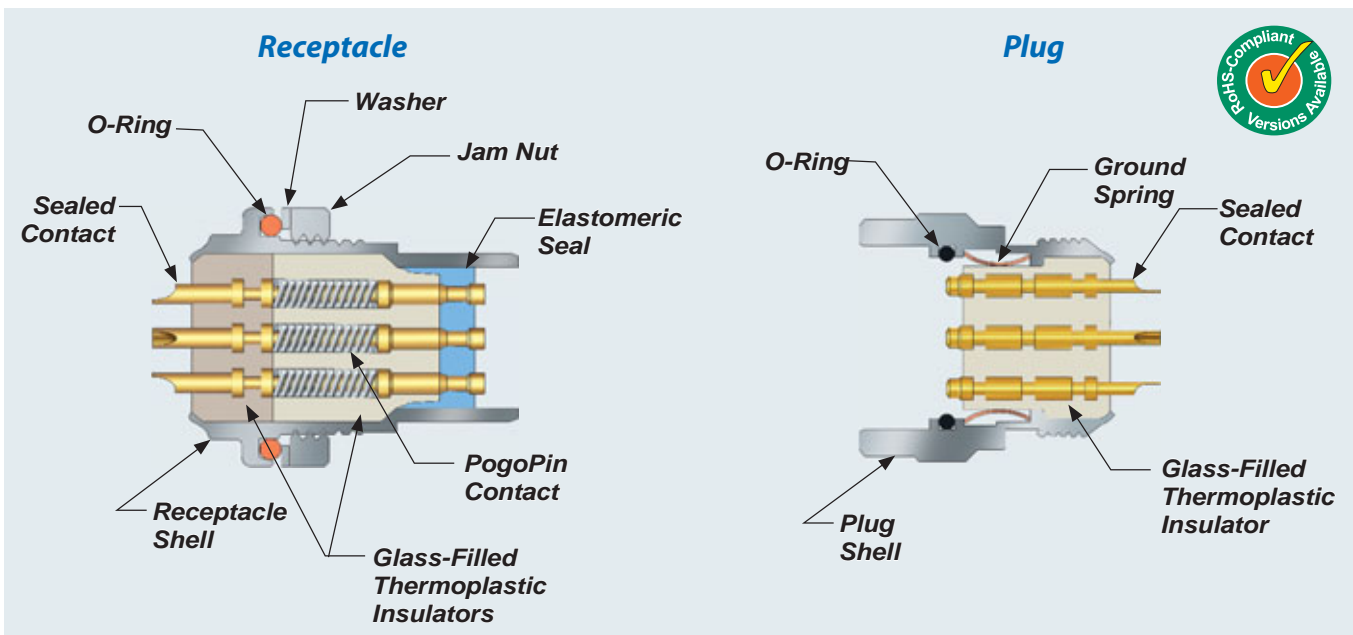
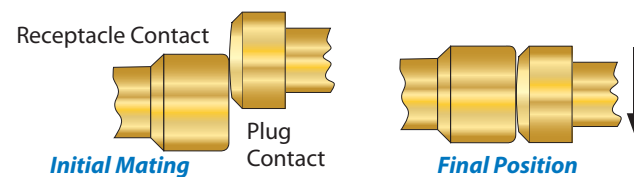

Series 15 Audio Connectors  
MIL-DTL-55116 Type



MIL-DTL-55116 Type Audio Plug, Field Serviceable with Wire Strain Relief      MIL-DTL-55116 Type Molded Audio Plug      MIL-DTL-55116 Type Audio Receptacle, Jam Nut Panel Mount      MIL-DTL-55116 Type In-Line Audio Receptacle with Wire Strain Relief

- IAW MIL-DTL-55116
- Advanced performance versions include improved sealing, package size reduction, and lightweight material options
- Overmolded cordsets
- Fully intermateable and intermountable with all industry-standard MIL-DTL-55116 connectors

**MIL-DTL-55116 type audio plugs for high-reliability, mission-critical communication systems—now available with advanced performance features including size/weight reduction and improved sealing**

MIL-DTL-55116 Specifications	
Current Rating	5 AMPS
DWV	500 VAC sea level, high altitude 300 VAC
Insulation Resistance	1000 megohms minimum
Operating Temperature	-55° C. to +85° C.
Contact Resistance	0.050 ohms maximum
Water Immersion, Mated	6 ft, 48 hrs, mated condition, no leakage
Water Ingress, Mated	Ingress protection 67
Durability	3000 cycles of mating

Series 151 (standard) and 152 (advanced performance) MIL-DTL-55116 Type audio connectors are designed for high-reliability, severe environment radio communications equipment. They are available in both 5 pin and 6 pin configurations, with either crimp sleeve or solder cup pogo pin terminals. All feature versatile wire strain relief to protect cable conductors from damage. Shells are made of passivated stainless steel, contacts are gold plated copper alloy. Plug connector contacts are sealed in the unmated condition.

Connector Type	Contact Type	Contact Layout	MIL SPEC Slash Sheet	IAW MIL-DTL-55116	Glenair High Performance	Mates with
Cable Plug, with Strain Relief U-229	Crimp	5	M55116/1	151-001-1	152-001-1	151-003-1, 151-004-1, 151-004-3
		6	M55116/2	151-001-2	152-001-2	151-003-2, 151-004-2, 151-004-4
	Solder	5	M55116/3	151-001-3	152-001-3	151-003-1, 151-004-1, 151-004-3
		6	M55116/4	151-001-4	152-001-4	151-003-2, 151-004-2, 151-004-4
Cable Plug, Molded U-182	Crimp	5	M55116/5	151-002-1	152-002-1	151-003-1, 151-004-1, 151-004-3
		6	M55116/6	151-002-2	152-002-2	151-003-2, 151-004-2, 151-004-4
	Solder	5	M55116/7	151-002-3	152-002-3	151-003-1, 151-004-1, 151-004-3
		6	M55116/8	151-002-4	152-002-4	151-003-2, 151-004-2, 151-004-4
Receptacle, Jam Nut U-183	Solder	5	M55116/9	151-003-1	152-003-1	151-001-1, 151-001-3, 151-002-1, 151-002-3
		6	M55116/10	151-003-2	152-003-2	151-001-2, 151-001-4, 151-002-2, 151-002-4
In-Line Receptacle U-228	Crimp	5	M55116/11	151-004-1	152-004-1	151-001-1, 151-001-3, 151-002-1, 151-002-3
		6	M55116/12	151-004-2	152-004-2	151-001-2, 151-001-4, 151-002-2, 151-002-4
	Solder	5	M55116/13	151-004-3	152-004-3	151-001-1, 151-001-3, 151-002-1, 151-002-3
		6	M55116/14	151-004-4	152-004-4	151-001-2, 151-001-4, 151-002-2, 151-002-4

QPL AND COMMERCIAL

# MIL-AERO

## CIRCULAR CONNECTORS

### ENVIRONMENTAL, HERMETIC, AND FILTER CLASS CYLINDRICAL CONNECTORS

MIL-DTL-38999 and other Environmental Connectors



Series 970 PowerTrip™ Connectors



MIL-DTL-38999 and other Hermetic Connectors



Series 22 Geo-Marine® Connectors



Sav-Con® Connector Savers and Adapters

MIL-DTL-5015, 26482 and other Industrial Connectors



MIL-DTL-28840 Connectors



EMI/EMP Filter Connectors

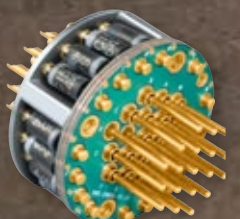

From satellites to ruggedized shipboard and industrial applications, Glenair supplies literally every power, signal, or high-speed cylindrical connector configuration. From our QPL'd MIL-DTL-38999 hermetic connectors to our revolutionary Series 970 PowerTrip™ solution, Glenair now leads the industry in the design and development of high-performance, mission critical military/aerospace connectors.





MIL-DTL-38999 and Other Environmental Connectors

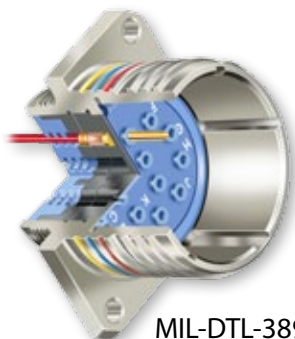

MIL-DTL-38999 Series III type Cutaway View

- Engineered solutions from standard MIL-DTL-38999 to exotic derivatives: High density, push-pull, lanyard release, high temperature, ground plane, compliant pin, zero extraction force, thru-bulkhead, quadrax, space-grade, and every other imaginable derivative
- Liberal policies on NRE costs, minimum order quantities and delivery schedules. Huge same-day shipment inventory



New! SuperSeal™ USB and RJ45 connectors with poke-and-crimp contact termination, IP67 sealing and robust EMI shielding



**QPL, catalog, and made-to-order mil-aero cylindrical connectors from the most accommodating engineering/manufacturing team in the business**

Environmental MIL-DTL-38999 Specifications	
Current Rating	#22D, 5 AMPS; #20, 7.5 AMPS; #16, 13 AMPS; #12, 23 AMPS; #10 33 AMPS
Dielectric Withstanding Voltage	500 VAC RMS at 50,000 feet; 350 VAC RMS at 70,000 feet; 200 VAC RMS at 100,000 feet;
Insulation Resistance	5000 megohms at 25°C
Thermal Shock	-65° C to +175° C
Shock and Vibration	300 G's; 37 G's random vibration
Shell-to-Shell Resistance	2 Millivolt drop maximum
Shielding Effectiveness	50 dB at 10 GHz
Durability	500 mating cycles IAW MIL-DTL-38999 paragraph 3.11

AS39029 QPL and Other Supported Contacts



Standard Catalog Connector Designs Available For Every Mil/Aero Connector Series

Standard	Miniature	Subminiature	Derivatives
MIL-DTL-5015 • MIL-DTL-22992 VG95234 (ITS) • MIL-DTL-28840	MIL-DTL-26482 MIL-DTL-26500 MIL-DTL-83723	MIL-DTL-38999	Thru-Bulkheads Connector Savers Exotic Contacts

MIL-DTL-38999 and Other Environmental Connectors



Crimp Quadrax Pin and Socket Contacts				
Contact Size	Type	Glenair Part Number	Cable Type Dash No.	Wire Size
#8	Quadrax	854-001	-01 - Tensolite NF26Q100	26AWG
			-02 - Tensolite NF24Q100	24AWG
		854-002	-03 - Draka Fileca F 4704-6	26AWG
			-04 - Draka Fileca F 4704-4	24AWG

Standard Signal Contact Current Rating and Supported Wire Sizes			
Contact Size	Test Current (Amps)	Max Millivolt Drop	Wire Gauge
22D	5	73	#22 - #28
20	7.5	55	#20 - #24
16	13	49	#16 - #20
12	23	42	#12 - #14
10	33	33	#10 - #12

Innovative Termination Technologies

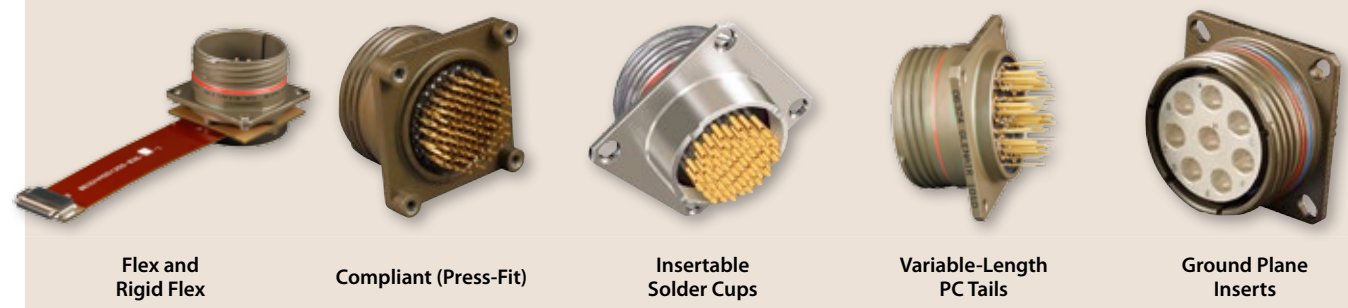

Innovative Shell Package Modifications

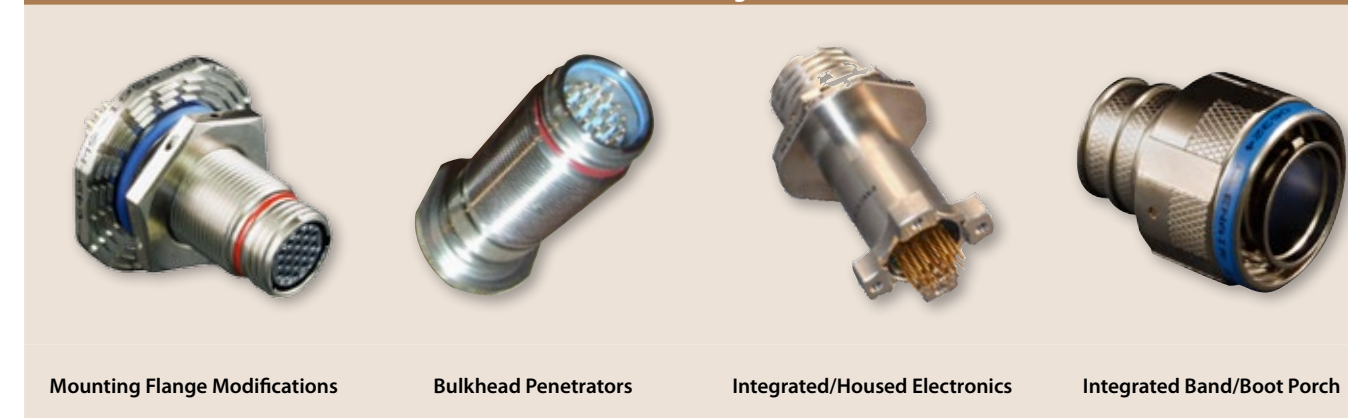

Innovative Mating Technologies







## MIL-DTL-38999 and Other Glass-Sealed Hermetic Connectors



Concentric twinax  
hermetic



MT ribbon  
fiber optic hermetic

- Enhanced Reliability
- Superior Pressure Resistance to 32,000+ PSI
- Higher Resistance to Extreme Operating Temperatures to 260°+ C
- Superior Mechanical Strength
- No Material Breakdown or Aging Over Time
- Helium Leak rate <math> < 1 \times 10^{-7} \text{ cc/sec} < /math> to <math> 1 \times 10^{-10} < /math>

**Resolve gas, moisture and particle ingress problems with advanced-performance glass-sealed hermetic connectors**

Glass-sealed MIL-DTL-24308, MIL-DTL-83513 and Series 79 Micro-Crimp hermetic connectors

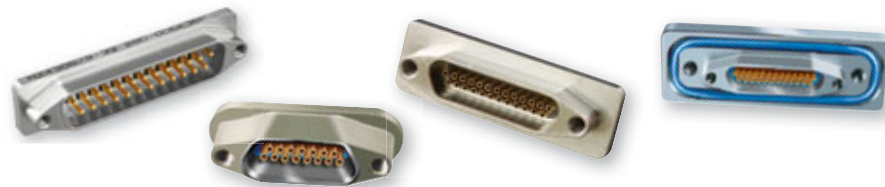

### Range of Standard Catalog Glass-Sealed Hermetic Connector Series Available with Accelerated Lead Times



MIL-DTL-26482



MIL-DTL-83723



MIL-DTL-38999 (QPL)



MIL-DTL-5015



Series 80 Mighty Mouse

### Matched vs. Compression Seal Technologies

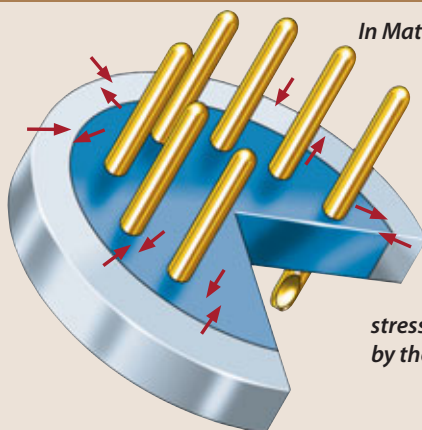

*In Matched Seal hermetics, thermal expansion of the glass and metal materials is relatively small—an important factor in the design of Micro-D hermetic connectors, due to varying degrees of stress on the glass caused by the rectangular shape.*

*In Mismatched (Compression) Seals, the thermal expansion/contraction of the metal exceeds that of the glass. During cooling, the metal contracts into the already solidifying glass to form an extremely robust compression bond.*

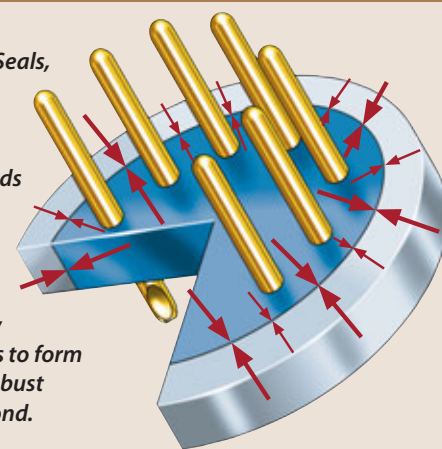

## MIL-DTL-38999 and Other Glass-Sealed Hermetic Connectors

Industry-Wide Sealing Rating System			
Connector Type	Ingress Protection	Helium Leak Rates Over Time	Sealing Method
Dust Tight	IP 65 (water jets)		Elastomer and/or epoxy
Environmental	IP 66 (powerful water jets)		Elastomer and/or epoxy
Environmental	IP 67 (immersion up to 1m)		Elastomer and/or epoxy
Environmental	IP 68 (immersion beyond 1m)		Elastomer and/or epoxy
Semi Hermetic		1 X 10 <sup>-4</sup> (1 cc/3 hours)	Epoxy Special
Hermetic		1 X 10 <sup>-4</sup> (1 cc/3 hours)	Glass (soft) to Metal
Hermetic		1 x 10 <sup>-5</sup> (1 cc/24 hours)	Glass to Metal
Hermetic		1 X 10 <sup>-6</sup> (1 cc/2 weeks)	Glass to Metal
Hermetic		1 x 10 <sup>-7</sup> (3 cc/year)	Glass to Metal
Hermetic		1 X 10 <sup>-8</sup> (1 cc/3 years)	Glass to Metal
Hermetic		1 X 10 <sup>-10</sup> (1 cc/300 years)	Glass to Metal

Kovar shell and contact are optimum for rectangular hermetic connectors • Hermetic leak rate = CC He/Sec

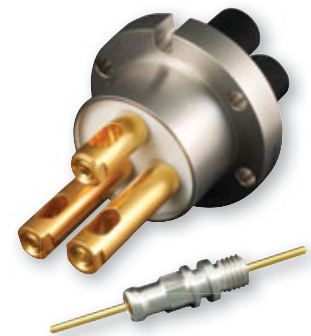

Hermetics for geophysical and offshore applications

### MIL-DTL-38999 Hermetic Specifications

Shock and Vibration	300 G's Shock; 37 G's Random Vibration
Thermal Shock	-40° C to + 90° C
Operating Temperature	D (FT) -65° C to +150° C; E and Y (Z1), and N (ZL) -65° C to +200° C
Mating Cycles	500 Mating Cycles
Corrosion Resistance	1000 Hours on Stainless Steel Shells
Shielding Effectiveness	Effective over a range of 100MHz to 10GHz with a minimum 50dB effectiveness at 10GHz, IAW test method EIA-364-10
Shell-to-Shell Resistance Series I & II (with spring fingers)	E (Z1) 2.5 Millivolt drop maximum N (ZL) 1 Millivolt drop maximum D (FT) N/A
Shell-to-Shell Resistance Series I & II	ALL - 200 Millivolt
Shell-to-Shell Resistance Series III & IV	N (ZL) 1 Millivolt H & Y (Z1S, Z1) 10 Millivolt

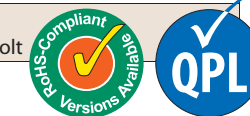

### MS and Commercial Part Number Cross Reference

MS Part Number	Glenair Part Number	Description
MS27469	231-100-H0	Series I Wall Mount
MS27470	231-100-H7	Series I Jam Nut
MS27471	231-100-H5	Series I Solder Mount
MS27475	232-100-H0	Series II Wall Mount
MS27476	232-100-H2	Series II Box Mount
MS27477	232-100-H7	Series II Jam Nut
MS27478	232-100-H5	Series II Solder Mount
D38999/21	233-100-H2	Series III Box Mount
D38999/23	233-100-H7	Series III Jam Nut
D38999/25	233-100-H5	Series III Solder Mount
D38999/27	233-100-H8	Series III Weld Mount
D38999/41	234-100-H2	Series IV Box Mount
D38999/43	234-100-H7	Series IV Jam Nut
D38999/45	234-100-H5	Series IV Solder Mount
D38999/48	234-100-H8	Series IV Weld Mount

### MIL-DTL-38999 QPL Pin and Socket Hermetics



Series I  
Scoop-Proof, 3 Point  
Bayonet Coupling  
Four Alternate Key Positions:  
A, B, C, D

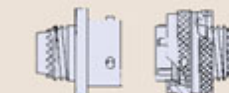

Series II  
Low Profile, 3 Point  
Bayonet Coupling  
Four Alternate Key Positions:  
A, B, C, D

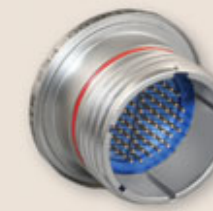

Series III  
Scoop-Proof, Triple Start,  
Self-Locking  
Five Alternate Key Positions:  
A, B, C, D, E



Series IV  
Scoop-Proof, Breech Lock  
Nine Alternate Key Positions:  
A, B, C, D, K, L, M, R, U



## Series 970 PowerTrip™ Connectors



Lightweight plug with ratcheting coupling nut and LouverBand contacts

Keyed receptacle with superior sealing and EMI shielding

- Fast, easy mating with triple-start ACME thread: 360° turn for full mating
- Reduced size and weight compared to MIL-DTL-5015
- LouverBand sockets for improved current ratings and longer life
- Splined backshell interface for improved backshell attachment and EMI shielding
- Ratcheting coupling nut for secure mating
- Operating temperature -65° C to +200° C

### PowerTrip™ The power connector for extreme environments



MIL-DTL-5015 contact arrangements



MIL-DTL-38999 triple-start coupling



MIL-DTL-28840 splined backshell interface



Series 970 PowerTrip™

#### Series 970 PowerTrip™ Connector Styles



Plug 970-001



Square Flange Receptacles 970-003



Jam Nut Receptacles 970-004



Cable Receptacles 970-005



Feed-Thru Bulkhead 970-006



Hermetic Feed-Thru Bulkhead 970-007

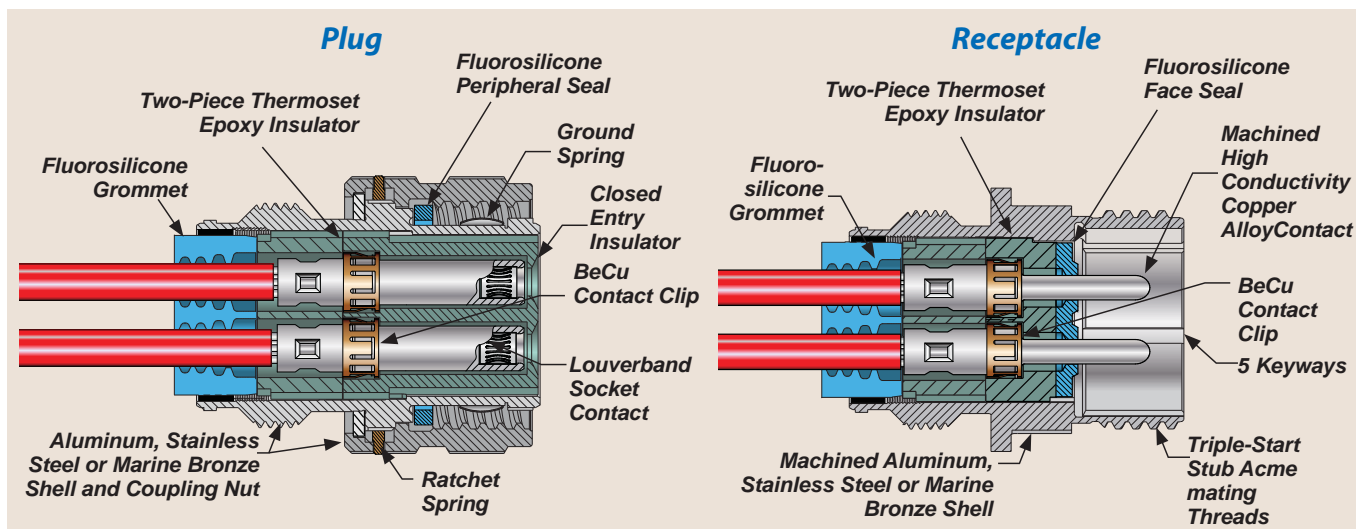

## Series 970 PowerTrip™ Connectors

### Superior current ratings of LouverBand vs. conventional split-tine contacts

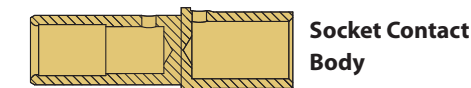
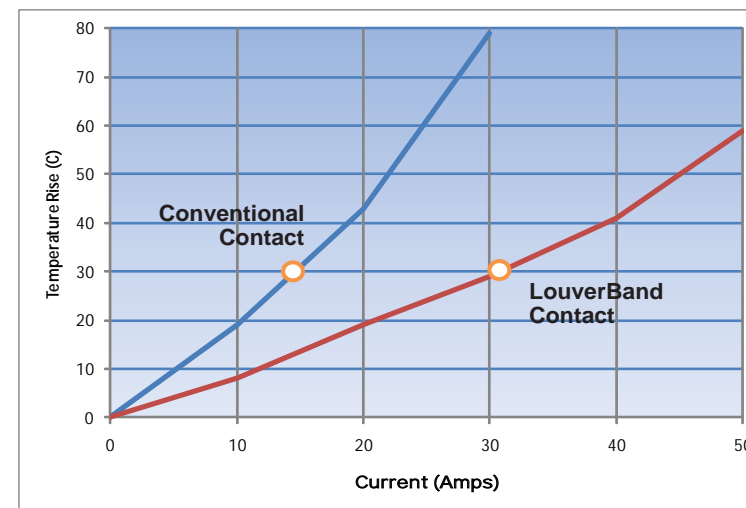

Split-tine contact on the left, LouverBand contact on the right

PowerTrip™ Materials	
Shells, Jam Nuts	Aluminum alloy, stainless steel or marine bronze
Contacts	High conductivity copper alloy, gold or silver-plated
Insulators	Glass-reinforced epoxy
Contact Retention Clip	Beryllium copper alloy
Seal, O-rings, Grommet	Fluorosilicone rubber
Spring	Nickel-plated beryllium copper



Heavy-duty PowerTrip™ backshells may be ordered by using the "P" connector designator in any standard backshell series part number

Series 970 PowerTrip™ Specifications	
Current Rating	Up to 225 A.
Dielectric Withstanding Voltage	2000 VAC
Insulation Resistance	5000 megohms minimum
Operating Temperature	-65° C. to +200° C.
Shock	300 g.
Vibration	37 g.
Shielding Effectiveness	65 dB minimum from 1GHz to 10GHz.
Durability	2000 mating cycles

Series 970 Contact Arrangements						
Principal Contact Size	Contact Arrangement	Contact Size and Qty				
		#16	#12	#8	#4	#1/0
Size #8	18-2			2		
	18-4		2	2		
	20-3			3		
	20-5		2	3		
	20-7	4		3		
	20-4			4		
Size #4	24-5			5		
	24-2				2	
	24-6		4		2	
	24-3				3	
	24-A6		3		3	
	28-4				4	
Size #1/0	28-9	5			4	
	32-5				5	
	32-2					2
	32-4				2	2
	32-3					3
	32-6		3			3
	36-4					4
	40-5					5



MIL-DTL-5015, 26482 and other  
Industrial Power and Signal Connectors

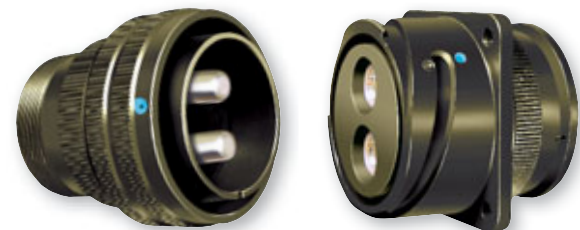

VG95234 qualified (MIL-DTL-5015 type)  
bayonet-lock connectors

- Over 200 power and signal contact arrangements (crimp and solder); over a dozen connector styles
- Coupling technologies include threaded, reverse bayonet, triple-start stub ACME and more
- Flame-resistant, caustic substance-free material choices for RoHS and other compliance standards
- Engineered and priced for industrial applications



Industrial power and signal connectors for rugged applications—from military vehicles to rail cars

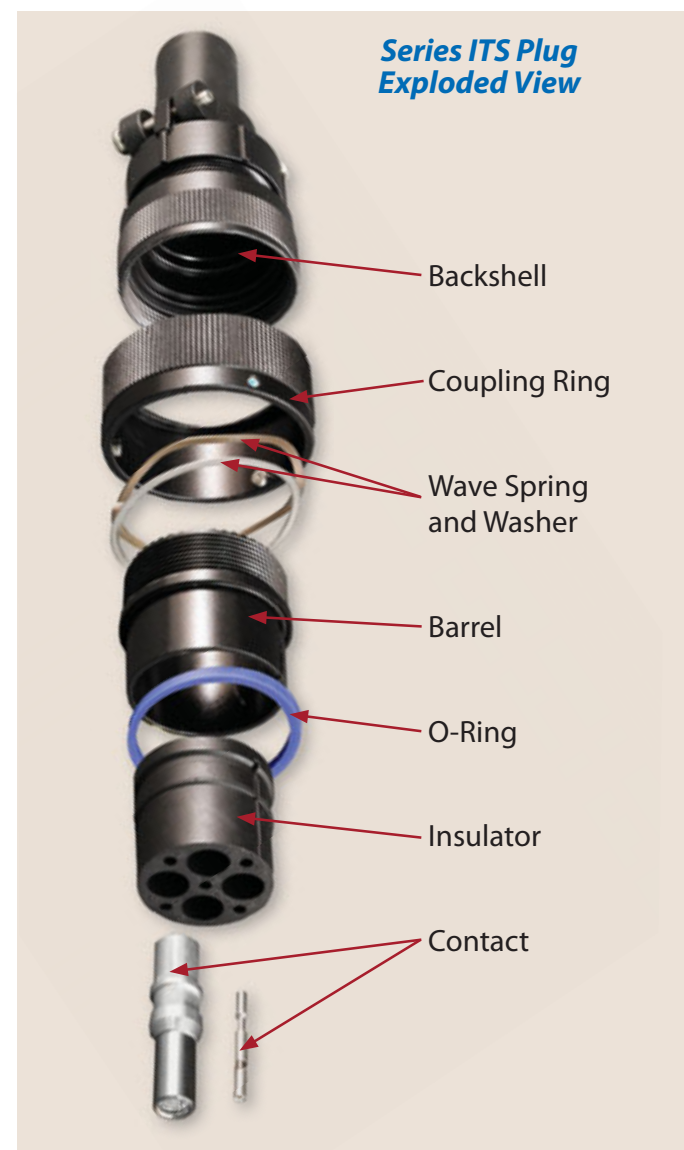

Series ITS Plug Exploded View

Series Variants

- Series ITS - Reverse-Bayonet MIL-DTL-5015 Type
- Series IT - Threaded Coupling MIL-DTL-5015 Type
- Series ITH - High Performance Rigid Insert 5015 Type
- Series IPT - MIL-C-26482 Type Bayonet
- Series IPT-SE - MIL-C-26482 Series II Type Bayonet
- VG95234 - Qualified Reverse-Bayonet 5015 Type
- VG95328 - Qualified MIL-C-26482 Type Bayonet
- VG96929 - Qualified Reverse-Bayonet Single-Pole
- Series ITZ - MIL-DTL-38999 Series III Type Power
- Series IRT - Rectangular Multi-Pole High Voltage Rail
- Series 901 - Reverse-Bayonet Medium Voltage Rail
- Series 500 - Reverse-Bayonet Single-Pole High Voltage
- Series UJ - Power Joint Connection System

Series ITS Standard Configurations

Shell Style	Description
ITS 00	Front panel mount square flange receptacle with accessory threads
ITS 01	In line cylindrical receptacle with accessory threads
ITS 030	Rear panel mount square flange receptacle with accessory threads
ITS 06	Straight cylindrical plug connector with accessory threads
ITS 02	Front panel mount square flange receptacle; No accessory threads
ITS 03	Rear panel mount square flange receptacle; No accessory threads
ITS 07	Rear panel mount jam nut receptacle; No accessory threads
ITS 08	90° cylindrical plug connector with accessory threads



MIL-DTL-5015, 26482 and other  
Industrial Power and Signal Connectors

Industrial Connector Product Families



High-Reliability Power Connectors for Rail Applications: Product Families



Industrial Power Contact Specifications

Copper alloy with silver plating (Std) or gold plating (available on request)

Contact Size	Rated Current at 20°C	Rated Current at 80°C	Max Contact Resistance	Wire Size
20	7.5 A	7.5 A	12.0 mΩ	20-26 AWG
18	10 A	7.5 A	12.0 mΩ	18-26 AWG
16	22 A	13 A	6.0 mΩ	16-22 AWG
12	41 A	23 A	3.0 mΩ	12-14 AWG
8	73 A	46 A	1.0 mΩ	8-10 AWG
4	135 A	80 A	0.5 mΩ	4-6 AWG
0	245 A	150 A	0.3 mΩ	0-2 AWG
4/0	350 A	225 A	0.2 mΩ	4/0 AWG



Series IFO Harsh-Environment Fiber Optic Connection System for Rail Applications



Series 22  
Geo-Marine® Connectors



Stainless steel plug with marine-bronze coupling nut  
Hermeticity rated receptacle: 1 X 10<sup>-6</sup> cc Helium per second

**The 5000 psi connector with extreme temperature and corrosion resistance**

Depth/Pressure Conversion			
Feet	Meters	P.S.I.	Bar
1	.3	.4	.0296
10	3.1	4.3	.2965
50	15.2	21.7	1.4962
100	30.5	43.3	2.9854
250	76.2	108.3	7.4670
500	152.4	216.5	14.9271
1,000	304.8	433.0	29.8543
1,500	457.2	649.5	44.7814
2,500	762.0	1082.5	74.6357
5,000	1524.0	2165.0	149.2715
10,000	3048.0	4330.0	298.5430
11,547	3519.35	5000.0	344.7379

Cable/Wire D.C. Resistance	
Copper Conductors at Room Temperature	
AWG	Ohms per 1000 feet
28	66.2 Max
26	41.6 Max
24	26.2 Max
22	16.5 Max
20	10.4 Max
18	6.5 Max
16	4.1 Max
14	2.6 Max
12	1.6 Max

- Environmentally and hermetically sealed connectors for rugged geophysical and marine applications
- Contact layouts from two to 128 contacts
- Anti-vibration, anti-decoupling device on all plugs
- Locksmith-keyed polarization
- Full line of accessories, covers and molding solutions

Performance Characteristics			
Hydrostatic Pressure Rating	5000 psi (fully mated)		
Operating Temperature Range	-65°C to +150°C		
Durability	500 Cycles of mate/demate		
Class H Hermetic Receptacles			
Open-Face Pressure Rating	1000 to 5000 psi		
Hermeticity	Less than 1 X 10 <sup>-6</sup> cc Helium per second		
Current Rating	Environmental	Hermetic	
Contact Size 22	5 amps	3 amps	
Contact Size 20	7.5 amps	5 amps	
Contact Size 16	13 amps	10 amps	
Contact Size 12	23 amps	17 amps	
Service Rating	Suggested Operational Voltage (Sea Level)		Test Voltage (Sea Level)
	AC(RMS)	DC	
M	400	550	1300 VMRS
N	300	450	1000 VMRS
I	600	850	1800 VMRS
II	900	1250	2300 VMRS
Insulation Resistance	1000 Megohms minimum at 500 VDC		

Overmolded cable assemblies featuring Viton® chemical resistant materials deliver advanced levels of sealing and durability.

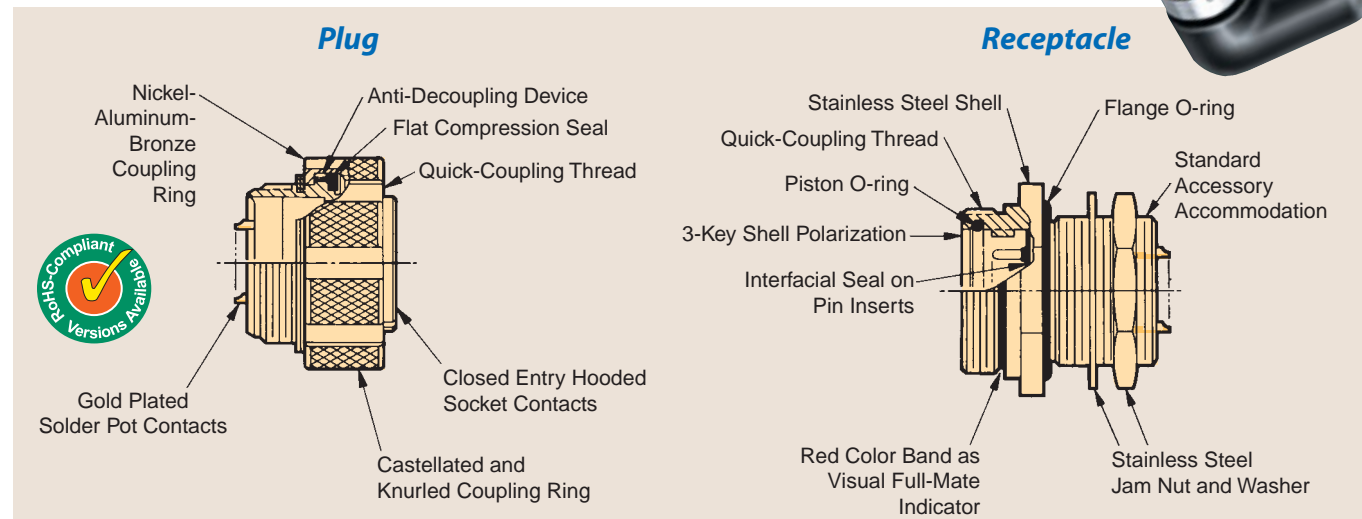
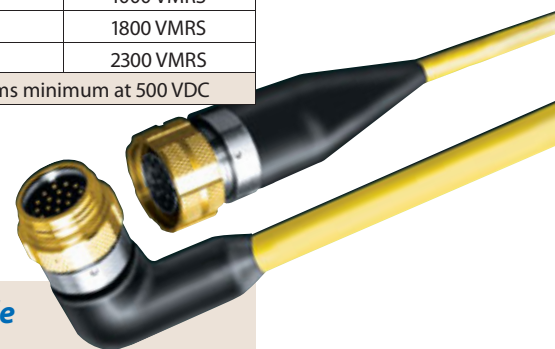

Series 22  
Geo-Marine® Connectors



Geo-Marine® Contact Arrangements

Front Face of Pin Inserts Illustrated. Service Ratings Indicated in Parentheses.

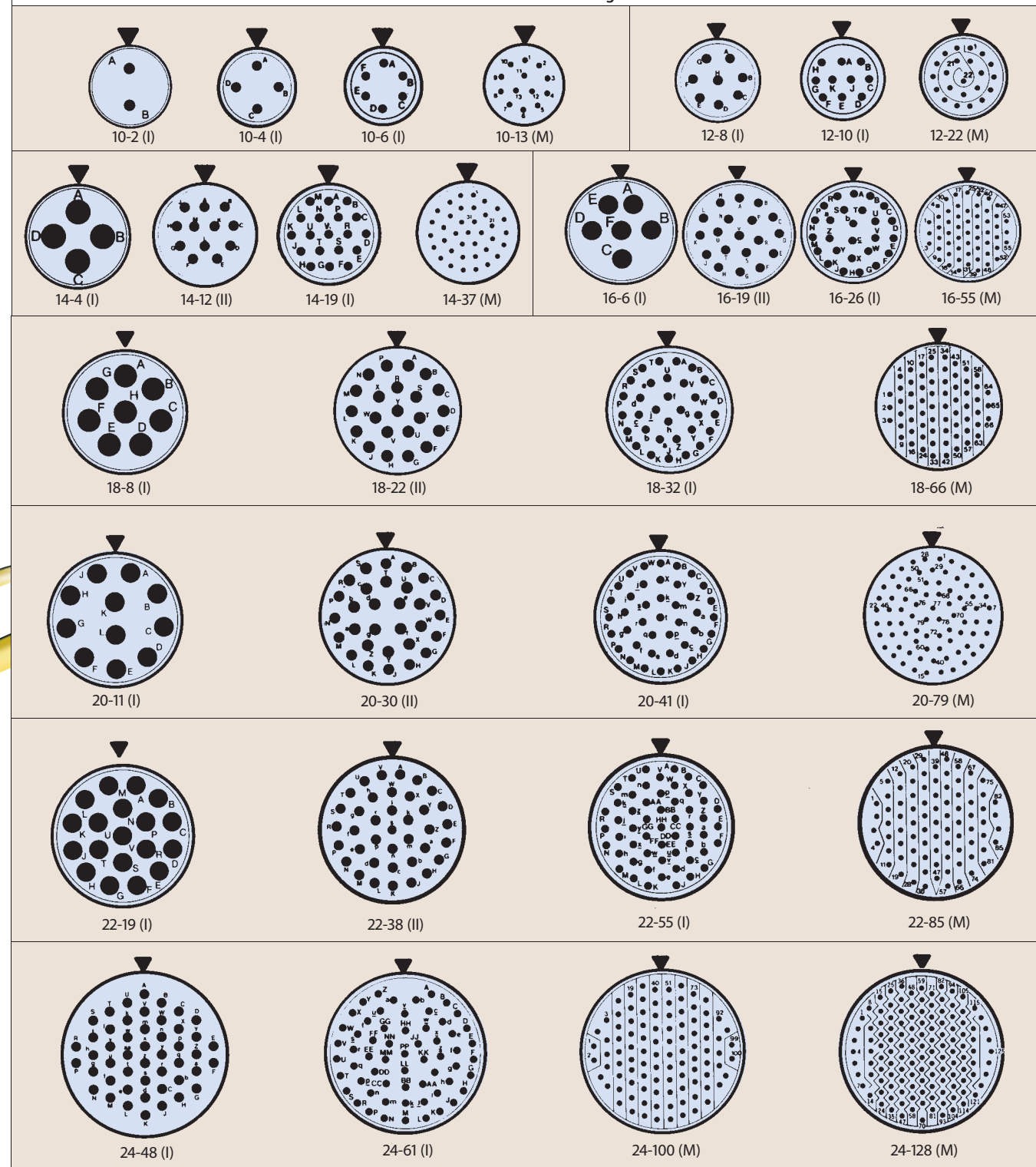



## EMI/EMP Filter Connectors



Planar filter arrays and TVS diodes may be integrated into virtually any connector packaging

- Planar, multilayer ceramic capacitive filters, with and without transient voltage suppression diodes
- C, L-C, C-L and Pi filter electrical configurations
- PC tail, solder cup or crimp-contact termination
- 10 to 1,000,000 pF capacitance
- -55° to +125°C standard operating temperature range with selected designs available for higher operating temperatures
- Fast and reliable diode burn-in and test services

**High reliability EMI/EMP filter connectors resolve even the most difficult EMC challenges**



Performance Ratings	
Shock and Vibration	IAW MIL-DTL-38999
Thermal Shock	-55° C to +125° C per EIA-364-32; 380 cycles
Operating Temperature	-55° C to +125° C
Mating Cycles	500 Mating Cycles
Corrosion Resistance	1000 Hours on Stainless Steel Shells
Shielding Effectiveness	Effective over a range of 100MHz to 10GHz with a minimum 50dB effectiveness at 10GHz
Immersion Rating	MIL-STD-810 Method 512; 1 Meter for 1 Hr. (selected series)
Shell-to-Shell Resistance	2.5 Millivolt drop maximum, per EIA-364-83

Electrical Performance	
Current Rating	up to 220 Amps
Capacitance	10pF to 1,000,000pF
Insulation Resistance	5GΩ
Dielectric Withstanding Voltage	100 to 2500 VDC
Dissipation Factor	2.5% Max
Diode Clamping Voltage Range	3.3V to 260V
Diode Peak/Pulse Power	up to 30KW

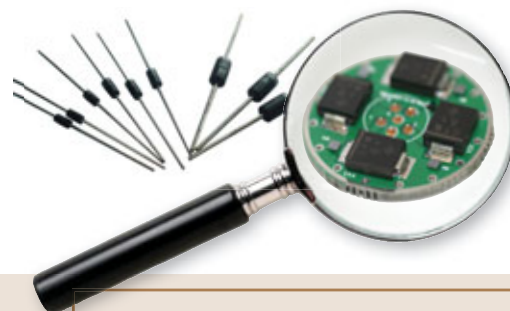

Glenair's state-of-the-art diode burn in process tests led and surface mount diodes with leakage current monitored throughout the entire test procedure, ensuring field reliability.

### Filter Module Elements

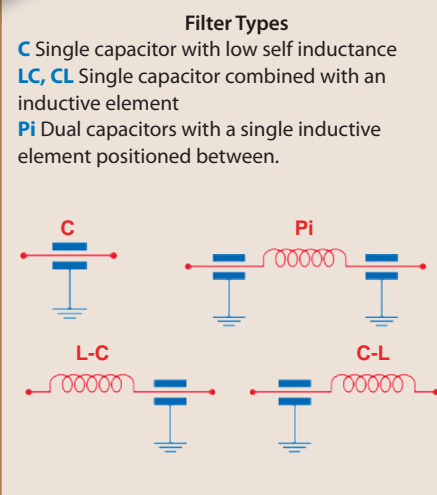
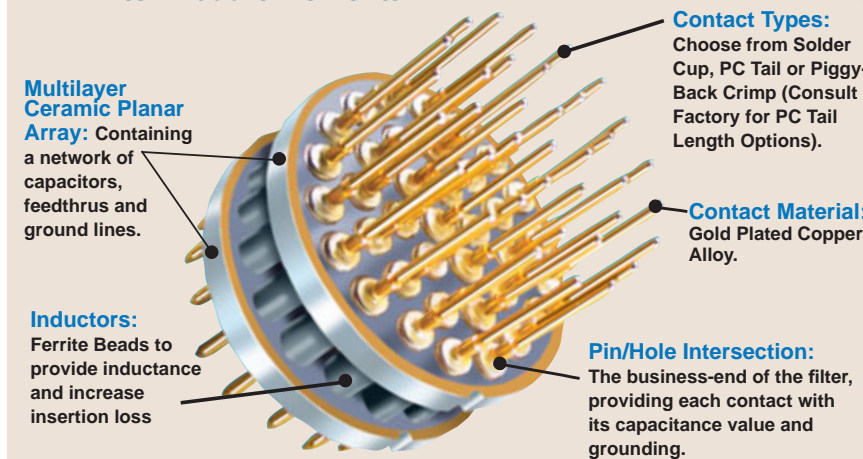

## EMI/EMP Filter Connectors

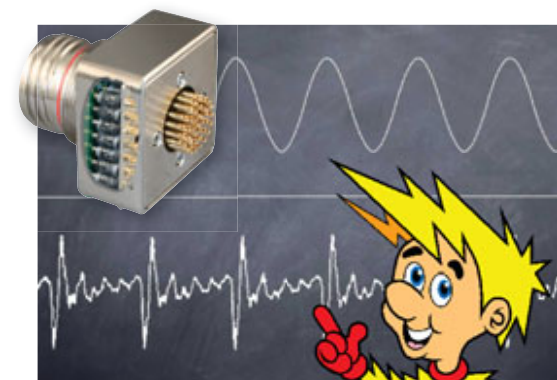

When specifying transient voltage suppression for a given lightning strike waveform (or "shape") and level (or magnitude), diodes must be compatible with EMI filter dielectric withstanding voltage (DWW) rating.

### The Industry's Most Comprehensive and Compliant Filter Service

Connector Series:		Line Types:	
38999	83513	CAN BUS	TTL
26482	5015	ARINC 429	Analog Sensors
83723	Series 80	RS 232	Thermocouple Wires
28840	Series 79	RS 422	USB
24308	Series ITS	RS 485	Ethernet
ARINC 600			

Requirement Compliance:	
MIL-STD-449D	RF Spectrum
MIL-STD-461E	EMI Susceptibility
MIL-STD-1310G	Shipboard EMC
MIL-STD-1512	Electroexplosive Subsystems
MIL-STD-1541A	EMC for Space Systems
MIL-STD-1795A	Aerospace Lightning Protection
MIL-STD-1857	Grounding, Bonding and Shielding
MIL-STD-1542B	EMC and Grounding for Space Systems
EN 61000-4-2...4-3, 4-4, 4-5, 4-6, 4-8	Electromagnetic, RF and Power
RTCA/DO-160 Section 22	Pin and Cable Level and Waveform

### Unique and Special Purpose EMI/EMP Filter Connectors

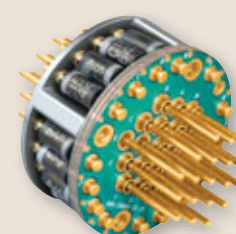

EMI Filter Package with TVS EMP Diodes



Unique Filter Package with Sidecar Filter Elements



ARINC Rack and Panel Filter Connector

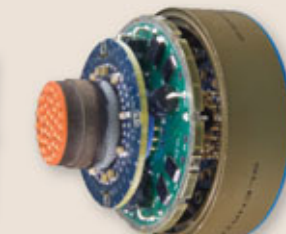

EMP Diode-Equipped Connector with Oversized Shell

### EMI Filter Rating in Dielectric Withstanding Voltage (DWW) For Compatibility with Transient Suppressing Diodes

DO 160 Waveform	Level	Waveform (Voc)	Capacitance pF Minimum							
			19000	16000	9000	4000	1650	400	200	
1 MHz Damped Ringing Sine	1	100	500	500	500	500	500	500	500	500
	2	250	500	500	500	500	500	500	500	500
	3	600	500	500	500	670	720	720	720	720
	4	1500	740	840	1210	1660	1800	1800	1800	1800
	5	3200	1580	1790	2580	3530	3840	3840	3840	3840
Double Exponential 6.4 x 70 μsec	1	50	500	500	500	500	500	500	500	500
	2	125	500	500	500	500	500	500	500	500
	3	300	500	500	500	500	500	500	500	500
	4	750	820	850	900	900	900	900	900	900
	5	1600	1920	1920	1920	1920	1920	1920	1920	1920
Double Exponential 40 x 120 μsec	1	50	500	500	500	500	500	500	500	500
	2	125	500	500	500	500	500	500	500	500
	3	300	500	500	500	500	500	500	500	500
	4	750	900	900	900	900	900	900	900	900
	5	1600	1920	1920	1920	1920	1920	1920	1920	1920



Qualified MIL-DTL-28840  
Connectors and Accessories



MIL-DTL-28840 qualified connectors  
in-stock and ready for immediate,  
same-day shipment

- High Density, Scoop Proof Contact Arrangements
- Flange Mount, Box Mount, Jam-Nut and In-Line Receptacles
- Straight, 45° and 90° Strain Reliefs and Backshell Assemblies
- Sav-Con® Connector Savers
- MIL-DTL-28840 Qualified
- Additional Glenair Commercial Part Numbers with Features Not Available in the Mil-Spec

Qualified military standard electrical connectors  
and accessories for shipboard—and all rugged  
environmental applications



Splined  
MIL-DTL-28840  
connector-to-backshell  
interface is ideally suited for  
heavy backshells and cables

Performance Specifications	
Current Rating (Maximum)	Size #20 Contact; 20AWG 7.5A, 22AWG 5.0A, 28AWG 1.5A, 30AWG 1.0A
Test Voltage (DWV)	1000 VAC RMS at sea level. Test per EIA-364-20
Insulation Resistance	5000 megohms minimum (at ambient temperature) per EIA-364-21
Contact Resistance	Per SAE-AS39029
Operating Temperature	-55° C. to +200° C.
Immersion	per test method EIA-364-09
Shock	in accordance with MIL-S-901 grade A
Vibration	per EIA-364-28 test procedure
Magnetic Permeability	2.0 μ (Aluminum), 5.0 μ (Stainless Steel) maximum; ASTM-A342/A342M

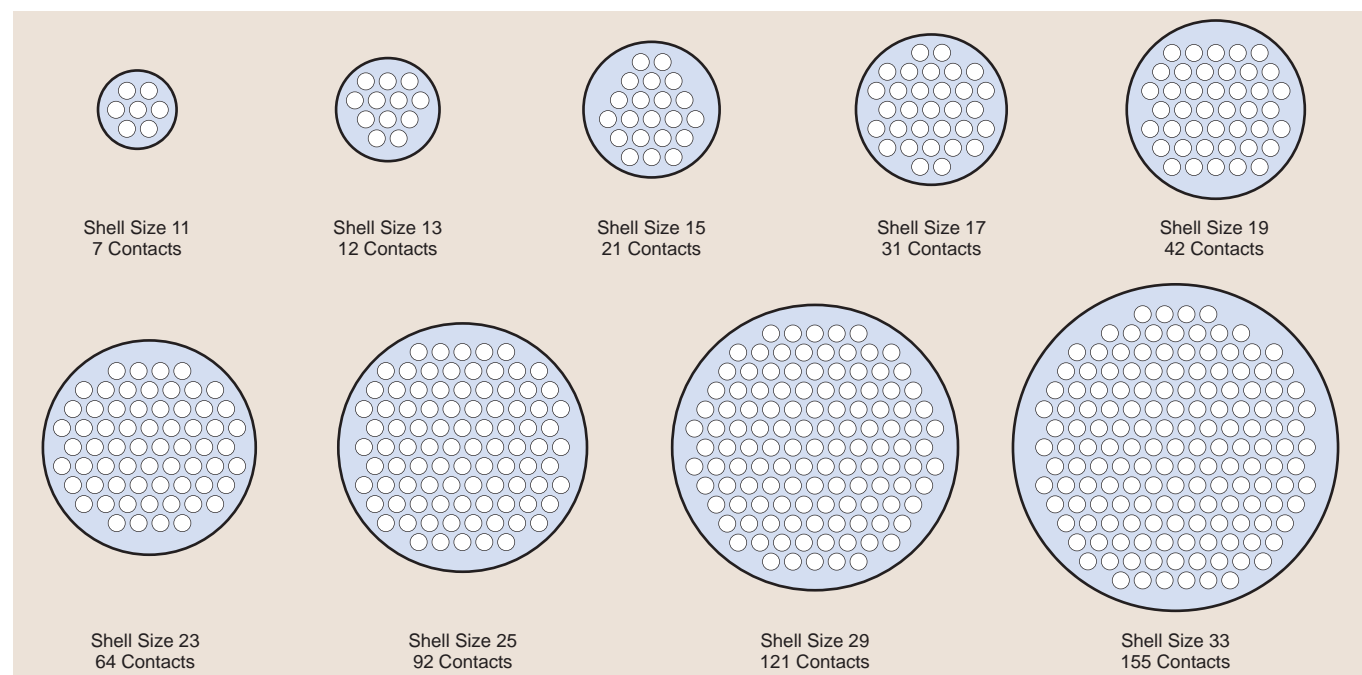

Qualified MIL-DTL-28840  
Connectors and Accessories

Standard Pin Crimp Contact for MIL-DTL-28840 Connectors

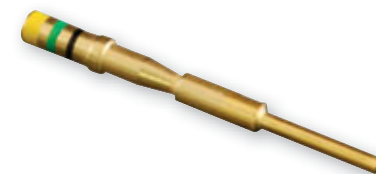

Mating End Size	Wire Accomodation	Military Part Number	Glenair Part Number
20	28-32 AWG	M39029/83-451	850-004-20-451
20	22-26 AWG	M39029/83-450	850-004-20-450
20	20-24 AWG	M39029/83-508	850-004-20-508

Standard Socket Crimp Contact for MIL-DTL-28840 Connectors



Mating End Size	Wire Accomodation	Military Part Number	Glenair Part Number
20	28-32 AWG	M39029/84-453	850-005-20-453
20	22-26 AWG	M39029/84-452	850-005-20-452
20	20-24 AWG	M39029/84-509	850-005-20-509

 Crimping Tools	 Insertion & Removal Tools	 Pin Contact	 Socket Contact
M22520/34-01 Basic Crimp Tool M22520/34-02 Positioner M22520/35 Gage	M81969/33-01 Straight Insertion Tool M81969/33-02 Offset Insertion Tool M81969/34-01 Removal Tool	M39029/83 Standard Duty Electrical Pin Contact	M39029/84 Standard Duty Electrical Socket Contact
 Environmental Backshells	 EMI/RFI Environmental Backshells	 Connector Sockets	 "E" Nuts Strain Reliefs
M28840/6 B Straight M28840/9 B 45° M28840/8 B 90°	M28840/6 A Straight M28840/8 A 90° M28840/9 A 45°	600G005	M28840/23 Non-Self-Locking Non-Self-Locking
M28840/1 Straight M28840/3 45° M28840/2 90°			
 Dummy Stowage Receptacles	 Protective Plug Covers	 Protective Receptacle Covers	 Jam Nuts Mounting Flanges and Gaskets
M28840/7	M28840/15	M28840/13	MS3186 M28840/24 Gasket
			MIL-PRF-24758A Conduit Fittings M24758-14 Straight (M24758/14 Straight.) M28840/5 Straight • M28840/25 90° • M28840/27 45° • M28840/30 Coupling



Sav-Con® Connector Savers



- For every Military Standard connector
- All standard materials and finish platings
- Fully repairable general duty, environmental, filter, hermetic and high-reliability performance classes
- Pin/pin, pin/socket, socket/socket versions, as well as gender changers
- Optional locking mechanism
- Keyed polarization



**Sav-Con® Connector Savers are the smart solution for preventing contact damage and extending the service life of cable assemblies**

**Glenair Makes a Sav-Con® Connector Saver for Every Military Standard Connector Currently in Use**

- MIL-DTL-26482 Series I and II
- MIL-DTL-28840
- MIL-DTL-38999 Series I, II and III
- MIL-DTL-83733
- LN 29729 (SJT)
- PATT 105 and PATT 602
- MIL-DTL-5015
- Series 801 and 805 Mighty Mouse
- M24308 Subminiature
- Micro-D Subminiature UniSaver
- Filtered Micro-D Subminiature
- Hermetic Solutions
- Series 28 HiPer-D
- Series 79 Micro-Crimp
- EMI/EMP Filter Specials



Sav-Con® Connector Savers

**Each Glenair Sav-Con® Connector Saver Meets the Military Specification Performance Requirements of its Mating Connector**

Military Specification Compliance			
Characteristic	Class 0	Class 1	Class 2
<b>Mechanical</b>			
Mating/Unmating Forces	Yes	Yes	Yes
Durability	Yes	Yes	Yes
Insert retention	Yes	Yes	Yes
Contact Retention	Yes	Yes	Yes
Coupling Pin strength	Yes	Yes	Yes
Contact Engagement & Disengagement Forces	Yes	Yes	Yes
Resistance to Probe Damage	Yes	Yes	Yes
EMI Ground Spring Forces	Yes	Yes	Yes
<b>Electrical</b>			
Contact Resistance	Yes	Yes	Yes
Electrical Engagement	Yes	Yes	Yes
Insulation Resistance	Yes	Yes	Yes
Dielectric	Yes	Yes	Yes
Withstanding Voltage	Yes	Yes	Yes
Magnetic Permeability	Yes	Yes	Yes
Electrical Conductivity	Yes	Yes	Yes

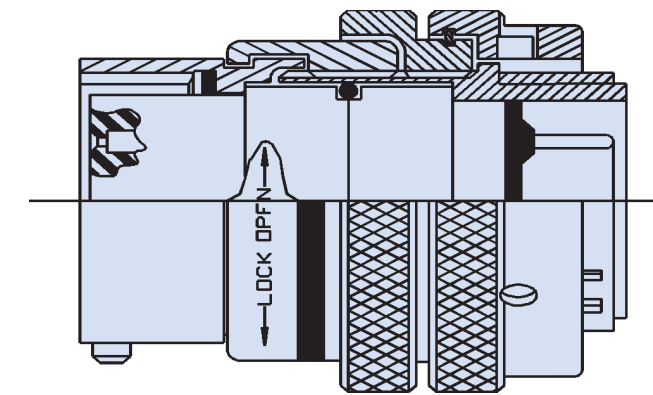

**Sav-Con® Lock Ring Prevents Accidental Disengagement of Bayonet Coupled Connectors**

Locking a Sav-Con® Connector Saver to a receptacle can prevent accidental or unauthorized unmating. This can insure that the equipment receptacle remains in its unused condition prior to delivery.

Table I: Materials and Finishes	
Shell, Barrel, and Coupling Nut (Environmental)	Aluminum alloy 6061-T6 per ASTM-B 211, 221, see catalog or consult factory for shell finishes
Front and Rear Insulators	Glass-filled liquid crystal polymer (LCP) in accordance with MIL-M-24519, Type GLP-30F
Contact Retention Clip	Beryllium copper, heat-treated, unplated
Grommet, Peripheral Seal and Interfacial Seal	Blended elastomer, 30% silicone per ZZ-R-765, 70% fluorosilicone per MIL-R-25988
Pin / Socket Contacts (Environmental)	Copper Alloy / Gold Plate
Socket Contact Hoods	Corrosion Resistant Steel IAW AISI303 Passivate QQ-P-35
Wave Spring (Bayonet Versions)	Stainless Steel 17-7PH, Condition C Passivate QQ-P-35
EMI Ground Springs	Beryllium Copper, Gold Plate MIL-G-45204
Adhesives	Silicone and epoxy
Potting Compound, PCB and Solder Cup Versions	Environmental and Hermetic Connectors: High-strength epoxy, Hysol EE4215. Filter Connectors: Stycast 2850FT/Catalyst 11 thermally conductive epoxy encapsulant.

HIGH-PERFORMANCE

# RECTANGULAR CONNECTORS

FROM NANOMINIATURE & MICRO TO D-SUB:  
THE INDUSTRY'S BEST PERFORMANCE AND AVAILABILITY

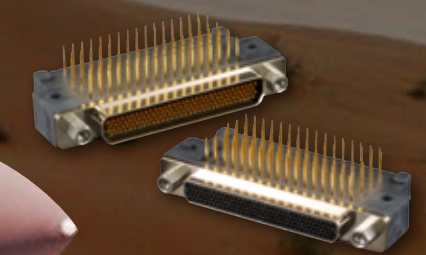

MIL-DTL-83513  
Micro-D  
Connectors



Series 28 HiPer-D 24308  
Compatible Connectors



Turnkey Harness  
Assemblies,  
Including Flex



Series 79  
Micro-Crimp  
Connectors

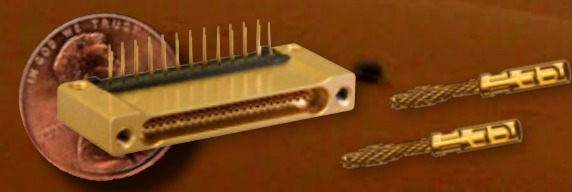

Series 89  
MIL-DTL-32139  
Nanominiature  
Connectors

Glenair manufactures all of the popular industry-standard rectangular connectors used in military and aerospace applications, including special high-performance versions of the M24308 D-Sub and our revolutionary Series 79 Micro-Crimp connector. We offer a small form factor rectangular connector for virtually every I/O and wire-to-board requirement. All of our rectangular connector products are available with flex circuit terminations, as well as turnkey point-to-point cordsets.







Series 89 MIL-DTL-32139  
Nanominiature Connectors

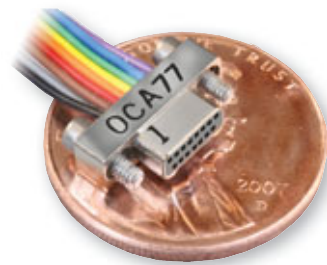

- 1 AMP Current rating
- .025 Inch (0.64 mm) Contact Spacing
- #30 and #32 Gage Wire Accommodation
- Single and Double Row
- Metal Shell, Aluminum, Titanium or Stainless Steel
- TwistPin Contact System
- Gold Alloy Contact, Unplated
- Thru-Hole and Surface Mount PCB Versions



**MIL-DTL-32139 Qualified Connectors for Mission-Critical Board-to-Wire Applications—Simply the Smallest and Lightest Mil-Spec Connector in the Business**

Now available from Glennair—Nanominiature circular connectors. Same nanominiature contact and wire spacing as our rectangular solutions, with superior mating and unmating performance and environmental resistance. Ideally suited for tactical applications.

**The Nano TwistPin Advantage**

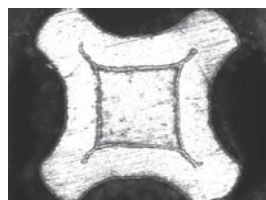

Transverse Cross-Section of a TwistPin Contact Crimped to Solid Wire

- Gas-Tight Crimp Joint
- Better Shock and Vibration Performance
- Corrosion Proof Contact Alloy

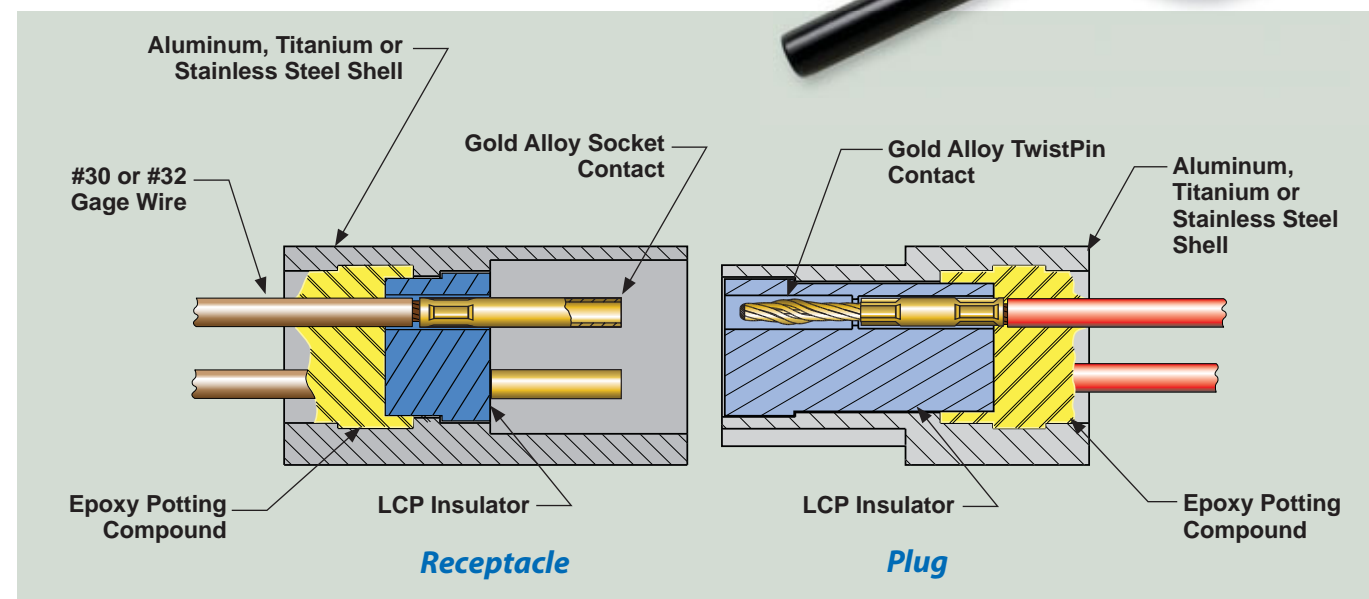

Series 89 MIL-DTL-32139  
Nanominiature Connectors

Series 89 Nanominiature Connector Performance Summary	
Contact Spacing	.025" (0.64mm) Contact Centers
Wire Accommodation	#30-#32 AWG
Current Rating	1 AMP Max
DWV	250 VAC RMS Sea Level
Insulation Resistance	5000 Megohms Minimum
Operating Temperature	-55° C. to +125° C.
Contact Resistance	71 Millivolt Drop Maximum
Shock, Vibration	100g's, 20 g's
Durability	200 Mating Cycles
Corrosion Resistance	48 Hours Salt Spray
Mating Force	5 Ounce Max, 0.4 Ounce Min

**Series 89 Nanominiature Product Selection Guide**

<b>Pre-Wired Single Row Connectors</b>					
<b>Pre-Wired PCB Connectors</b>					
<b>Pre-Wired Double Row Connectors</b>					
<b>Double Row PCB Connectors</b>					
<b>Pre-Wired MIL-DTL-32139 Connectors</b>					

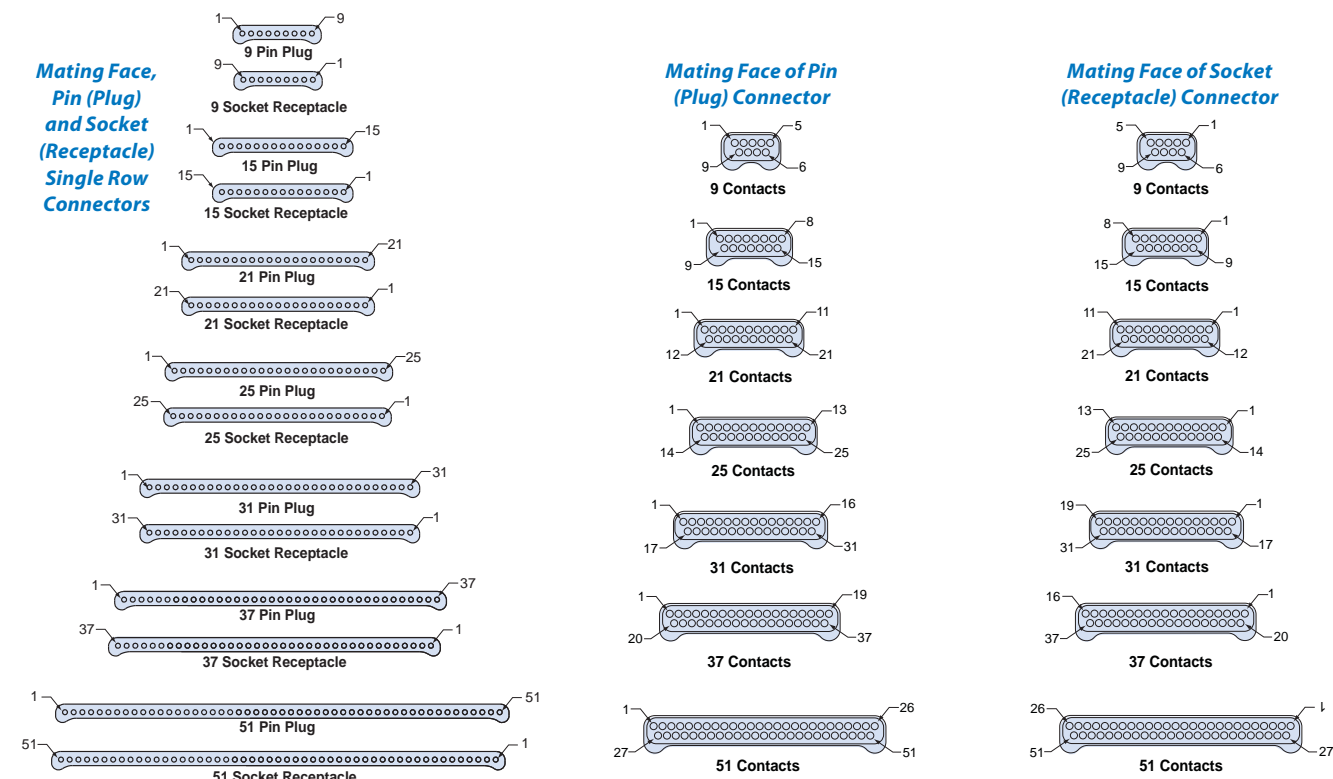



## MIL-DTL-83513 and Commercial Micro-D Connectors



- High density Micro TwistPin contacts set on .050 centers
- 9 to 130 contact contact arrangements
- Pigtail, PCB, solder cup, and flex terminations
- QPL and commercial versions
- Same-day availability on all part numbers

**TwistPin equipped MIL-DTL-83513 Micro-D connectors offer outstanding mating performance, durability and minimal contact resistance**



High-performance Micro TwistPin contacts

**PCB Termination**  
Versatile printed circuit board termination technologies include thru-hole PC tail, surface mount and FLEX circuit.



### Micro-D Backshells for Every Application Requirement

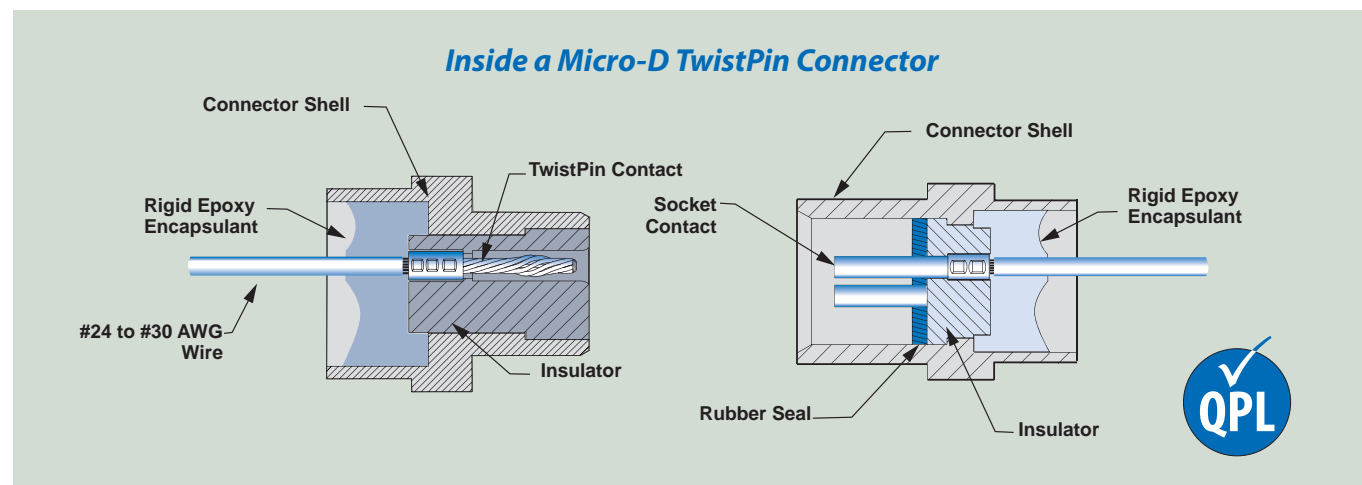

## MIL-DTL-83513 and Commercial Micro-D Connectors

Performance Specifications	
Current Rating	3 AMP
DWV	600 VAC Sea level
Insulation Resistance	5000 Megohms Minimum
Contact Resistance	8 Milliohms Maximum
Low Level Contact Resist.	32 Milliohms Maximum
Magnetic Permeability	2 μ Maximum
Operating Temperature	-55° C. to +150° C.
Shock, Vibration	50 g., 20g.
Mating Force	(10 Ounces) X (# of Contacts)

Materials and Finishes	
Connector Shell	Aluminum Alloy 6061 or Stainless Steel, 300 Series, passivated. See Ordering Info for Plating Options
Insulator	Liquid Crystal Polymer (LCP)
Interfacial Seal	Fluorosilicone Rubber, Blue
Pin Contact	Beryllium Copper Gold over Nickel Plating
Socket Contact	Copper Alloy Gold Over Nickel Plating
Hardware	300 Series Stainless Steel
Encapsulant	Epoxy Resin Hysol EE4215

Standard Insulated and Uninsulated Wire	
Pigtail Wire, Insulated Hookup	Wire Type E: Silver-Coated Copper Wire, Extruded PTFE Insulation, 600 Volts RMS, 200°C., IAW NEMA HP3 (Replaces MIL-W-16878/4) Wire Type K: Silver-Coated Copper Wire, Extruded PTFE Insulation, 600 Volts RMS, 200° C., IAW SAE AS 22759/11 Wire Type J: High-Strength Silver-Coated Copper Alloy Wire, Crosslinked Modified ETFE Insulation, 600 Volts RMS, 200° C., IAW SAE AS 22759/33
Pigtail Wire, Uninsulated	Wire Finish Code 3: Solid Copper Wire IAW A-A-59551, Gold-Plated, Solder Dipped in 63/37 tin-lead Wire Finish Code 4: Solid Copper Wire IAW A-A-59551, Gold-Plated

### Micro-D Product Selection Guide





## Series 28 HiPer-D M24308 Compatible Connectors



**Advanced Performance**  
M24308/D-Sub Intermateable

### The high-performance D-Subminiature for extreme land, air and space applications

- Improved environmental, EMI, mechanical performance and temperature tolerance (-65°C to +200°C) compared to standard commercial M24308 connectors
- Fits panel and PCB footprint of standard M24308/D Sub product
- Lightweight machined aluminum shells with integrated EMI ground springs and optional blind mate guide pins
- Available in all standard and high density contact arrangements



#20 Contacts

Contact Type	Fig.	Wire Size	Part Number	M39029 Part Number	Insertion and Removal Tool
Pin	1	#20-24	850-022-20-369	M39029/64-369	M81969/39-01
Socket	2	#20-24	850-021-20-368	M39029/63-368	859-017

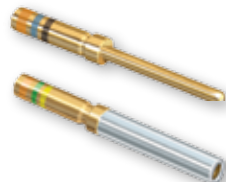

#22D Contacts

Contact Type	Fig.	Wire Size	Part Number	M39029 Part Number	Insertion and Removal Tool
Pin	1	#22-28	850-002-22-360	M39029/58-360	M81969/14-01
Socket	2	#22-28	850-003-22-354	M39029/57-354	859-020

#### Inside a Series 28 HiPer-D Connector

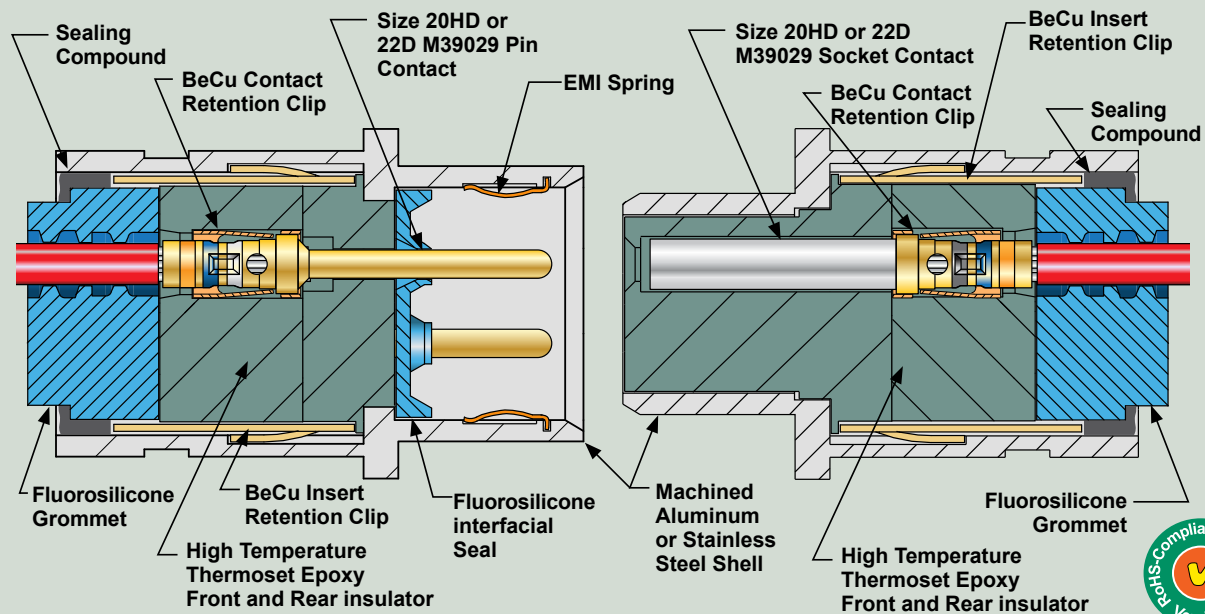

## Series 28 HiPer-D M24308 Compatible Connectors

### HiPer-D Contact Arrangements: Standard Density, #20 Contacts



**1S9**  
9 #20 Contacts

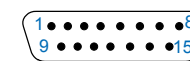

**2S15**  
15 #20 Contacts

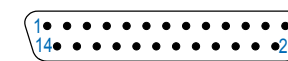

**3S25**  
25 #20 Contacts

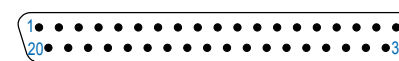

**4S37**  
37 #20 Contacts

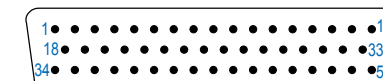

**5S50**  
50 #20 Contacts

Mating face of pin connector.

### HiPer-D Contact Arrangements: High Density, #22 Contacts

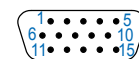

**1H15**  
15 #22D Contacts

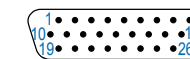

**2H26**  
26 #22D Contacts

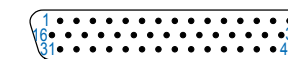

**3H44**  
44 #22D Contacts

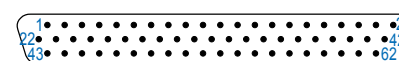

**4H62**  
62 #22D Contacts



**5H78**  
78 #22D Contacts



**6H104**  
104 #22D Contacts

#### Specifications

Current Rating	#22D 5 AMPS, #20 7.5 AMPS
Test Voltage	1000 VAC RMS
Insulation Resistance	5000 megohms minimum
Operating Temperature	-65° C. to +200° C.
Ingress Protection	IP 67
Shock	300 g.
Vibration, Random	43.92 g.

#### Materials and Finishes

Shell	Aluminum alloy
Contacts	Copper alloy, 50 microinches gold plated, stainless steel hood
Insulators	Thermoset epoxy
Retention Clips	Copper alloy
Grommet, interfacial Seal	Fluorosilicone rubber
Hardware	300 series stainless steel



289-003 Protective Cover for HiPer-D Pin Connectors



289-019 Protective Cover with Fluorosilicone Rubber Gasket



289-004 Protective Cover with EMI/RFI Spring and Gasket



SavCon® Connector Savers for HiPer-D Connectors

#### Series 28 HiPer-D Product Selection Guide

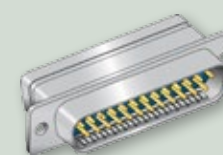

Cable Connectors



Panel Mount Connectors Crimp Termination

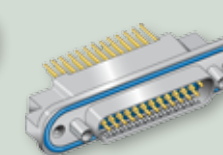

Straight PCB Connectors



Right Angle PCB Connectors



Connector Backshells and Accessories



## Series 79 Micro-Crimp Connectors



Cable Plug

Crimp Receptacle

**MICRO-CRIMP™**

- Crimp, PCB, fiber optic, coax, power, and pitot combo layouts
- Precision machined aluminum shells sealed to IP67
- High-density #23 contact contact arrangements set on .076 centers
- Blind mating for rack and panel applications
- Over 30 tooled contact arrangements
- Integrated ground spring for improved EMI shielding

Circular versions of the Micro-Crimp (Series 80 Mighty Mouse) are also available, see page B-2

### The high-performance rectangular with advanced EMC and environmental performance

#### Blind Mate Guide Pins and Sockets

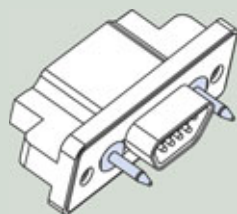

Guide Pins

Connector may be supplied with stainless steel non-removable guide pins.

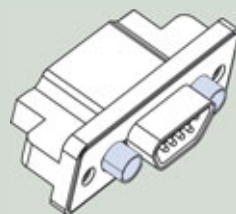

Guide Sockets

Connector may be supplied with stainless steel non-removable bushings.

#### Selected Contact Types



Standard Signal

Power

Coaxial

Differential Twinax

Fiber Optic

Pitot Tube

#### Inside a Series 79 Micro-Crimp Connector

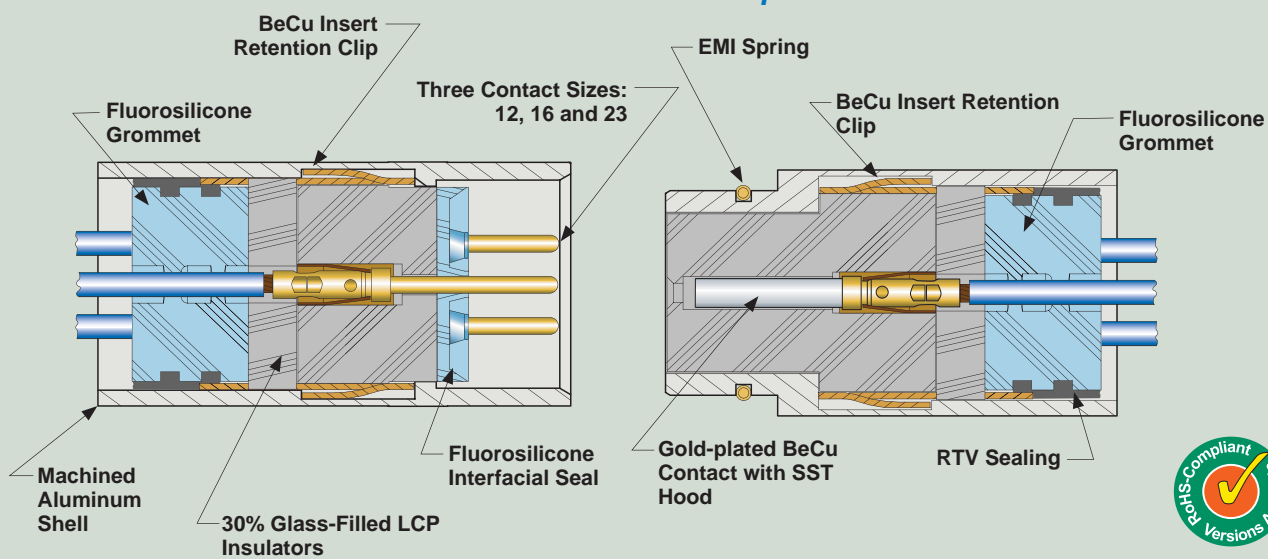

## Series 79 Micro-Crimp Connectors

Materials and Finishes	
Size #23 signal contacts	Copper alloy, plated gold over nickel
Size #16 and #12 signal/power contacts	Copper alloy, plated gold over nickel
Fiber optic contacts	Ferrule: Zirconia ceramic; Terminus assembly/spring: Stainless steel
Pitot tube contacts	Body and cap: Stainless steel; O-Ring: Fluorosilicone; Washers: PTFE
Insulators	Liquid crystal polymer, 30% glass-reinforced
Shell	Aluminum alloy
Interfacial seal and grommet	Fluorosilicone
Contact and insert retention clips	Beryllium copper, heat-treated, unplated
Jackposts and guide pins	Stainless steel, passivated
EMI Shroud for right angle PCB	Aluminum alloy
Trays for right angle PCB	Thermoplastic
Spring, EMI (plug)	Stainless steel or beryllium copper alloy, gold plated

Basic Specifications	
Current rating	Contact size #23 5 Amps, size #16 13 Amps, size #12 23 Amps maximum
Voltage rating (DWV)	Contact size #23 500 VAC rms. size #16 and #12 1800 VAC rms. Sea level.
Insulation resistance	5000 megohms minimum
Operating temperature	-65° C. to +150° C.
Contact resistance	5 milliohms maximum
Water ingress protection	IP67
Shielding effectiveness	>75 dB attenuation from 100 MHz to 1000MHz, >60dB 1GHz to 4GHz, >40dB 4GHz to 10GHz.

Shell Size	Contact Arrangement	Contact Quantity			Shell Size	Contact Arrangement	Contact Quantity			Shell Size	Contact Arrangement	Contact Quantity		
		#23	#16	#12			#23	#16	#12			#23	#16	#12
A	A-5	5	—	—	F	F-15P2	13	2	—	J	J-17P4	13	4	—
	B-2P2	—	2	—		F-23	23	—	—		J-25P2	23	2	—
B-9	9	—	—	F-5P5		—	5	—	J-33		33	—	—	
C	C-13	13	—	—	G	G-33	33	—	—	K	J-7P7	—	7	—
	D-15	15	—	—		H-10P4	6	—	4		K-27P4	23	4	—
	D-3P3	—	3	—		H-29P7	22	7	—		K-35P2	33	2	—
D	D-7P2	5	2	—	H	H-36P2	34	—	2	K-43	43	—	—	
	E-11P2	9	2	—		H-54P2	52	2	—	K-9P9	—	9	—	
E	E-19	19	—	—		H-5P5	—	—	5	L-6P6	—	—	6	
	E-7P3	4	3	—		H-66	66	—	—	L-78	78	—	—	
									M	M-102	102	—	—	

#### Series 79 Micro-Crimp Product Selection Guide



**QPL AND COMMERCIAL**

# HIGH-PERFORMANCE FIBER OPTICS

FOR LAND, SEA, AIR, SPACE, AND C4ISR APPLICATIONS

GHD High Density Fiber Optic Connection System



MIL-DTL-38999 Type Fiber Optic Connection System



GFOCA M83526 Compliant Fiber Optic Connection System



MIL-PRF-28876 Fiber Optic Connection System



Glenair fiber optic interconnect technologies deliver high data rate and bandwidth, reduced size and weight, EMI immunity, enhanced security, and spark/arc immunity. Our broad offering of fiber optic systems includes qualified MIL-PRF-28876 connectors and termini for shipboard applications, MIL-DTL-38999 type fiber optic connectors and termini for aerospace applications, as well as our revolutionary Eye-Beam™ Expanded Beam termini, and copper-to-fiber media converters.

Eye-Beam™ Expanded Beam Fiber Optics



Series 80 Mighty Mouse Fiber Optic Connection System



Copper-to-Fiber Media Converters/Active Components



Fiber Optic Termination, Test, and Cleaning Kits





## MIL-DTL-38999 Type Fiber Optic Connection System



MIL-DTL-38999  
Series III type plug  
and square flange wall-  
mount receptacle

- MIL-DTL-38999 type tight tolerance fiber optic connectors
- Composite thermoplastic and stainless steel shells available
- Qualified size #16 MIL-PRF-29504 precision ceramic termini
- Singlemode and multimode fiber, from 9/125 to 1000 microns
- Ultra-low insertion loss values, <.50dB typical
- From 2 to 37 Termini
- Plug and In-Line, Jam Nut and Square Flange Receptacles
- Patented MIL-DTL-38999 fiber optic test probes and adapters

**The high performance fiber optic interconnect system successfully deployed in hundreds of commercial and military aerospace applications—from F-16 upgrade systems to the revolutionary F-35 Joint Strike Fighter**

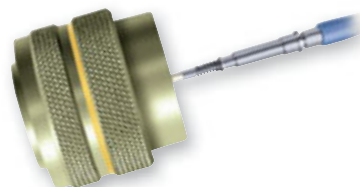

Glenair optical fiber test probes and connector adapters provide accurate and repeatable testing of MIL-DTL-38999 F/O assemblies

### Contact Arrangements

2 x 16 Ga Shell Size 11	4 x 16 Ga Shell Size 13	5 x 16 Ga Shell Size 15	8 x 16 Ga Shell Size 17	11 x 16 Ga Shell Size 19	16 x 16 Ga Shell Size 21	21 x 16 Ga Shell Size 23	29 x 16 Ga Shell Size 25	37 x 16 Ga Shell Size 25

Per MIL-STD-1560. Mating face of pin insert shown.



Terminated and tested point-to-point and multibranch  
D38999 type fiber optic cable assemblies

### MIL-PRF-29504/4 and /5 Fiber Optic Termini Performance Data

Test Type	Performance Requirement
Operating Temperature	-55°C to +165°C (dependent on epoxy and cable)
Temperature Cycling	-65°C to +175°C
Thermal Shock	-55°C to +150°C, 5 cycles
Temperature Life	+150°C for 1,000 hours
Random Vibration	20-2,000 Hz, 42.2 g's
Shock (Half-sine Pulse)	300 g Peak Load
Mechanical Shock	MIL-S-901, Grade A, Type B, Class 1
Mating Durability	500 cycles (cleaning after 100 matings)
Salt Spray	48 hours (Terminus only)
Cable Retention Force	22.0 lbs (dependent on cable construction)

## MIL-DTL-38999 Type Fiber Optic Connection System



MIL-DTL-38999 type fiber optic connection system termination, inspection, test, and cleaning tools are available now from Glenair. We also offer comprehensive F/O training services for assembly and maintenance technicians. Ask us about our fiber optic test probes.

### D38999 Type Fiber Optic Connector Part Numbers

Glenair Part Number*	Product Description
181-001	#16 Socket Terminus
181-002	#16 Pin Terminus
181-048	#16 Dummy Terminus
180-091 (05)	In-Line Receptacle Connector
180-091 (06)	Plug Connector
180-091 (08)	Jam Nut Mount Receptacle Connector
180-091 (H7)	Square Flange Wall Mount Receptacle with Standard Holes
180-091 (S7)	Square Flange Wall Mount Receptacle with Slotted Holes
180-091 (T7)	Square Flange Wall Mount Receptacle with Tapped Holes

\* See fiber optic catalog for complete part number information

### M29504/4 and /5 Type Fiber Optic Termini Part Numbers

Socket Termini		Pin Termini		Fiber Size Core/Cladding**	A Dia.** [microns]
Commercial	MIL-Spec	Commercial	MIL-Spec		
181-001-125	M29504/5-4237*	181-002-125	M29504/4-4208*	9/125 (Singlemode)	125.5
181-001-126S	M29504/5-4238*	181-002-126S	M29504/4-4209*	9/125 (Singlemode)	126.0
181-001-126	M29504/5-4239*	181-002-126	M29504/4-4210*	50/125, 62.5/125	126.0
181-001-127	M29504/5-4046	181-002-127	M29504/4-4040	50/125, 62.5/125	127.0
181-001-142	M29504/5-4049	181-002-142	M29504/4-4043	100/140	142.0
181-001-144	N/A	181-002-144	N/A	100/140	144.0
181-001-145	M29504/5-4050	181-002-145	M29504/4-4044	100/140	145.0
181-001-156	M29504/5-4240*	181-002-156	M29504/4-4211*	62.5/125/155 (Polyimide)	156.0
181-001-157	M29504/5-4241*	181-002-157	M29504/4-4212*	62.5/125/155 (Polyimide)	157.0
181-001-173S	M29504/5-4296*	181-002-173S	M29504/4-4293*	100/140/172 (Polyimide)	173.0
181-001-173	M29504/5-4088	181-002-173	M29504/4-4087	100/140/172 (Polyimide)	173.0
181-001-175	M29504/5-4242*	181-002-175	M29504/4-4213*	100/140/172 (Polyimide)	175.0
181-001-231	N/A	181-002-231	N/A	200/230	231.0
181-001-236	M29504/5-4243*	181-002-236	M29504/4-4214*	200/233	236.0
181-001-286	M29504/5-4244*	181-002-286	M29504/4-4215*	200/280	286.0
181-001-448	M29504/5-4245*	181-002-448	M29504/4-4216*	400/440	448.0
181-001-533	N/A	181-002-533	N/A	486/500	533.0

\* Consult factory for qualification status. • \*\* Consult factory for additional sizes.

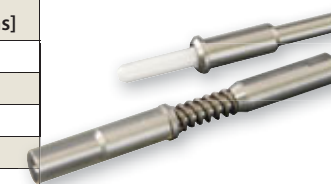

Glenair M29504/4 and /5 QPL termini are in stock and ready for immediate, same-day shipment



### Fiber Optic Termini Dimensional Data

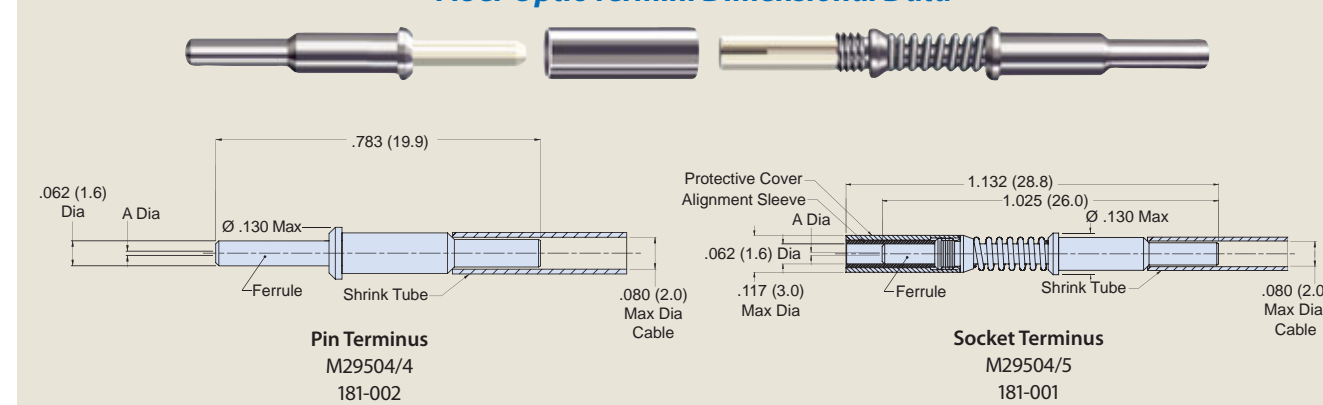



## Glenair High Density (GHD) Fiber Optic Connection System



GHD plug connector with alignment sleeve retainer, and square flange receptacle

- Innovative #18 (1.25mm ferrule) front-release genderless termini accommodate 900µ to 2.0mm jacketed fiber
- M85045/16 cable accommodation
- Single keying for APC polish available
- Better optical performance than D38999 with nearly double the density
- Precision alignment sleeve retainer with integrated guide pins
- Piston o-ring sealing—submersible design

**The system of choice for military and commercial air and space applications: Outstanding optical and environmental performance with nearly double the density of standard mil-spec designs**



Fiber Optic Pin Termini Specifications			
Assembly Dash Number		Fiber Size	A Dia.
Keyed	Non-Keyed	Core/Cladding	[microns]
181-047-1255	181-056-1255	9/125 (Singlemode)	125.5
181-047-1260	181-056-1260	9/125, 50/125, 62.5/125	126.0
181-047-1270	181-056-1270	50/125, 62.5/125	127.0
181-047-1420	181-056-1420	100/140	142.0
181-047-1450	181-056-1450	100/140	145.0
181-047-1560	181-056-1560	62.5/125/155 (Polyimide)	156.0
181-047-1570	181-056-1570	62.5/125/155 (Polyimide)	157.0
181-047-1730	181-056-1730	100/140/172 (Polyimide)	173.0
181-047-1750	181-056-1750	100/140/172 (Polyimide)	175.0
181-047-2360	181-056-2360	200/233	236.0
181-047-2860	181-056-2860	200/280	286.0

GHD Fiber Optic Part Number Reference	
Glenair Part Number	Product Description
181-047	#18 Pin Terminus, Keyed for APC Polish
181-056	#18 Pin Terminus (non-keyed)
181-058	#18 Dummy Terminus
180-122 (05)	In-Line Receptacle Connector
180-122 (06)	Plug Connector with Alignment Sleeve Retainer
180-122 (08)	Jam Nut Mount Receptacle Connector
180-122 (H7)	Square Flange Receptacle with Round Holes
180-122 (S7)	Square Flange Receptacle with Slotted Holes

\* See fiber optic catalog for complete part number information

Pin Density Cross-Reference: Glenair High Density Versus D38999 and M28876								
Connector Style / Size	11	13	15	17	19	21	23	25
D38999 Cavity Count	2	4	5	8	11	16	21	29/37
M28876 Cavity Count	2	4	6/8	N/A	N/A	N/A	18/31	N/A
GHD Cavity Count	4	6	16	20	30	40	52	70

### Glenair High Density (GHD) Features

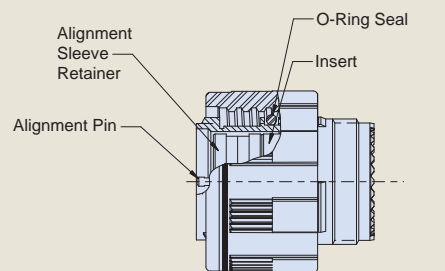

D38999 Series III Style Coupling  
Five Alternate Key Positions: A, B, C, D, E (N = Normal)

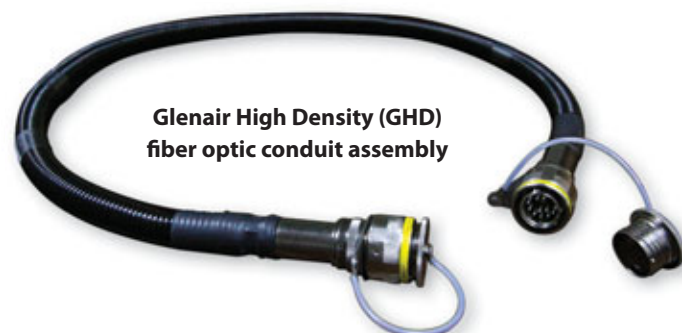

Glenair High Density (GHD)  
fiber optic conduit assembly



## Glenair High Density (GHD) Fiber Optic Connection System

### Contact Arrangements (Alignment Sleeve Retainer Face Shown)

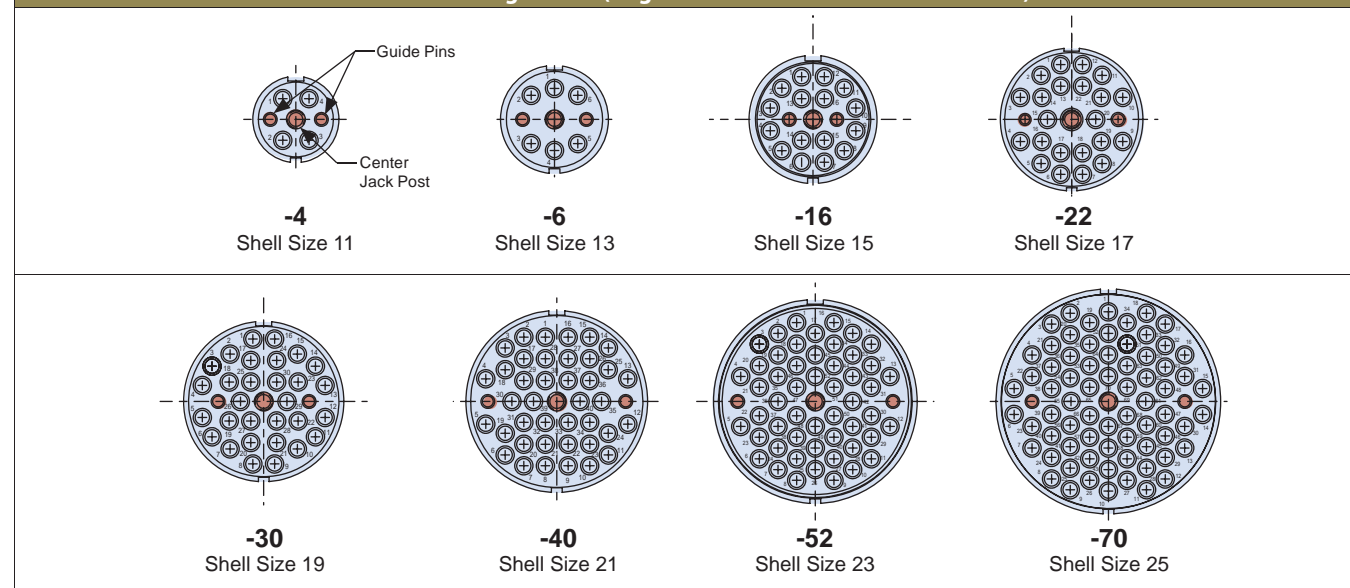

Termini available in keyed and non-keyed styles

### Glenair High Density (GHD) Fiber Optic Termini Dimensional Data

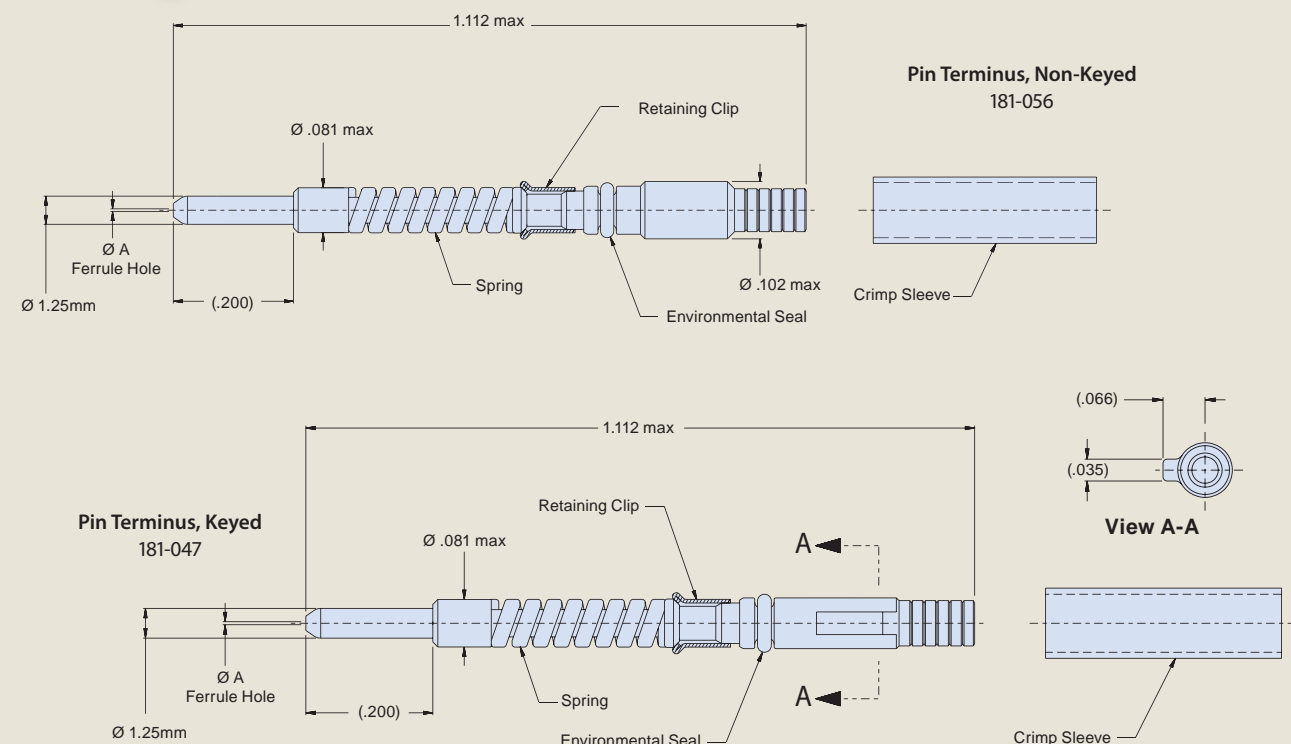



## Series 80 Mighty Mouse Fiber Optic Connection System



Series 801 Plug with 181-057 pin termini      Series 801 receptacle with 181-075 socket termini

- Three snap-in, rear release fiber optic termini sizes: #23, #20HD, and #16 for use in any Series 80 Mighty Mouse connector
- The smallest mil-aero caliber fiber optic connection system available
- Singlemode and multimode
- Precision ceramic ferrules
- 0.5 dB typical attenuation
- 1 to 130 channels



**The perfect marriage of high bandwidth fiber optics with ultra-miniature packaging—half the size of D38999**

### Series 80 Contact Arrangements For Use With #16 Fiber Optic Termini

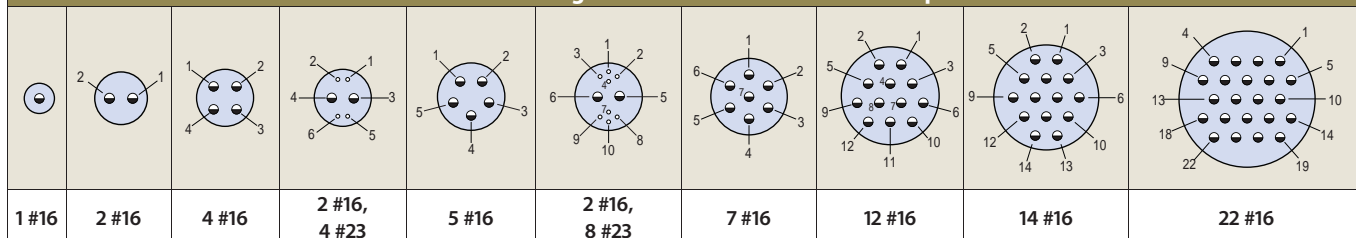

### Series 80 Contact Arrangements For Use With Size #20HD Fiber Optic Termini

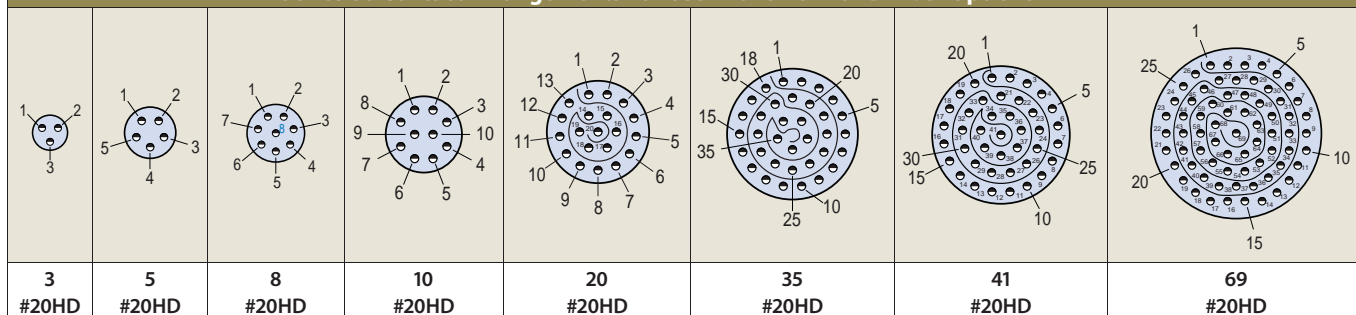

### Series 80 Contact Arrangements For Use With #23 Fiber Optic Termini

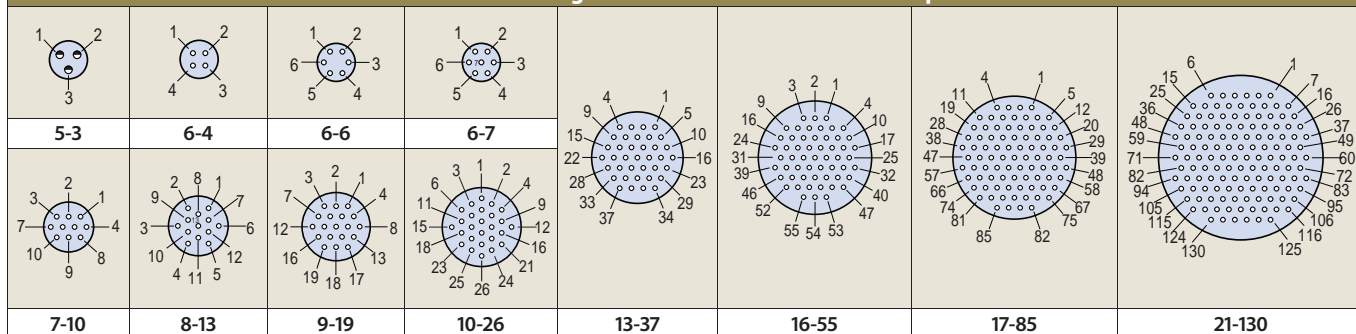

See Series 80 Mighty Mouse catalog for connector ordering information. Order connectors less contacts and order fiber optic termini separately. Cavity numbers are mating face view of pin connectors.



## Series 80 Mighty Mouse Fiber Optic Connection System

### Size #16 Fiber Optic Termini



181-057 Pin Terminus      181-075 Socket Terminus

Termini Type	Optical Fiber Type	Part Number	A Ferrule I.D.	Fiber Size Core/Cladding
Pin	Multi Mode	<a href="#">181-057-126</a>	126.0 microns	50/125, 62.5/125
	Single Mode	<a href="#">181-057-125</a>	125.5 microns	9/125
Socket	Multi Mode	<a href="#">181-075-126</a>	126.0 microns	50/125, 62.5/125
	Single Mode	<a href="#">181-075-125</a>	125.5 microns	9/125

\*Consult factory for additional sizes

Series 801 9-4 with size #16 fiber optic termini vs. equivalent functionality D38999



Series 801 Shell size 9, 4 channel 6 Grams (less contacts)      D38999 Series III Shell size 13, 4 channel 27 Grams (less contacts)

### Size #20HD Fiber Optic Termini



181-084 Pin Terminus      181-085 Socket Terminus

Termini Type	Optical Fiber Type	Part Number	A Ferrule I.D.*	Fiber Size Core/Cladding
Pin	Multi Mode	<a href="#">181-084-126</a>	126.0 microns	50/125, 62.5/125
	Single Mode	<a href="#">181-084-1255</a>	125.5 microns	9/125
Socket	Multi Mode	<a href="#">181-085-126</a>	126.0 microns	50/125, 62.5/125
	Single Mode	<a href="#">181-085-1255</a>	125.5 microns	9/125

\*Consult factory for additional sizes

Series 801 8-8 with size #20 HD fiber optic termini vs. equivalent functionality D38999



Series 801 Shell size 8, 8 channel 8 Grams (less contacts)      D38999 Series III Shell size 17, 8 channel 40 Grams (less contacts)

### Size #23 Fiber Optic Termini



181-063 Pin Terminus      181-064 Socket Terminus

Termini Type	Optical Fiber Type	Part Number	A Ferrule I.D.	Fiber Size Core/Cladding*
Pin	Multi Mode	<a href="#">181-063-126</a>	126.0 microns	50/125, 62.5/125
	Single Mode	<a href="#">181-063-1255</a>	125.5 microns	9/125
Socket	Multi Mode	<a href="#">181-064-126</a>	126.0 microns	50/125, 62.5/125
	Single Mode	<a href="#">181-064-1255</a>	125.5 microns	9/125

\*Consult factory for additional sizes

Series 801 6-4 with size #23 fiber optic termini vs. equivalent functionality D38999



Series 801 Shell size 6, 4 channel 5 Grams (less contacts)      D38999 Series III Shell size 13, 4 channel 21 Grams (less contacts)





MIL-PRF-28876  
Fiber Optic Connection System



M28876/2 receptacle with backshell

M28876/7 plug with backshell

- Connectors qualified to the complete requirements of MIL-PRF-28876 including plugs, wall-mount receptacles, jam-nut mount receptacles and in-line receptacles
- Multiple shell sizes and contact arrangements, including 2, 4, 6, 8, 18 and 31 channel layouts
- Backshells in straight, 45° and 90° configurations
- Corrosion-resistant and environmentally sealed
- Qualified MIL-PRF-29504/14 and /15 pin and socket termini and /3 dummy terminus
- Connectors, backshells and protective covers available for immediate, same-day shipment

**Qualified MIL-PRF-28876 fiber optic connectors and MIL-PRF-29504 termini—Navy approved, in stock, and ready for immediate shipment**

Contact Arrangements

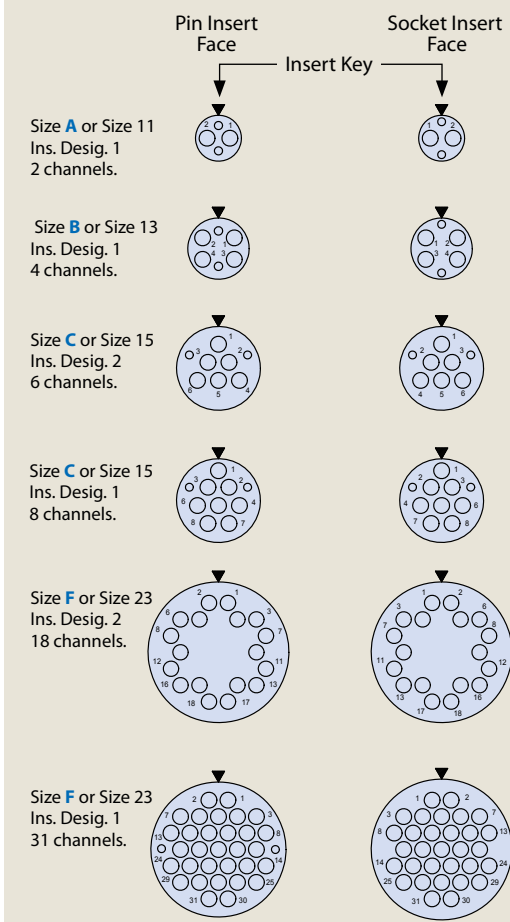

Test Description	Performance Requirements/ Specifications
Optical Insertion Loss, Multimode	-0.3 dB Typical (62.5/125)
Optical Insertion Loss, Singlemode	-0.3 dB Typical (9/125)
Optical Back Reflection, Singlemode	Better than -40 dB - PC Polish • Better than -50 dB - Enhanced PC Polish
Operating Temperature	-28°C to +65°C (MIL-Spec Epoxy and Cable) -55°C to +125°C (alternative Epoxy and Cable)
Temperature (Thermal) Shock	-40°C to +70°C, 5 Cycles
Temperature Cycling	-28°C to +65°C, 5 Cycles
Temperature/Humidity Cycling	-10°C to +65°C, 10 Cycles, 240 hours, 98% RH
Temperature Life Aging	+110°C, 240 hours, Dry Air
Mating Durability	500 cycles
Vibration - Sinusoidal	10 g Peak, 5-500 Hz sin./ 10.2 g RMS, 50-2000 Hz random
Impact	8 Drops from 8 feet
Crush Resistance	281 lbs, 7 Cycles
Cable Pull Out Force - Termini	Termini: 22 lbs min for 1 minute Connector: 162 lbs min for 10 minutes
Fluid Immersion	Turbine Fuel, Isopropyl Alcohol, Hydraulic Fluid, Lubricating Oil, Coolant, Tap- and seawater, 24 hrs
Water Pressure	32 feet for 48 hours at +10°C to +35°C
Mechanical Shock (High Impact)	MIL-S-901, Grade A, Type B, Class I
Corrosion Resistance (Salt Spray)	500 hours
Sand and Dust	12 hours
Flammability	0.75 inch flame for 10 sec. mated, 1.50 inch flame for 60 sec. unmated

\*Performance Specifications/Requirements based on the use of MIL-PRF-24792 Epoxy and MIL-PRF-85045 Simplex and Breakout Shipboard Optical Fiber.



MIL-PRF-28876  
Fiber Optic Connection System

Connector/Backshell Types			
Connector Type	Backshell Type	MIL-Spec	Commercial
Wall Mount Receptacle	None	M28876/1	03
	Straight	M28876/2	13
	45°	M28876/3	23
	90°	M28876/4	33
In-Line Receptacle	Straight	M28876/5	15
Plug	None	M28876/6	06
	Straight	M28876/7	16
	45°	M28876/8	26
	90°	M28876/9	36
Jam Nut Receptacle	None	M28876/11	04
	Straight	M28876/12	14
	45°	M28876/13	24
	90°	M28876/14	34

Qualified Fiber Optic Termini			
Type	Military Part Number	A Dia (Microns)	Typical Fiber Type
Pin Termini	M29504/14-4131	126.0	Multi Mode
	M29504/14-4132	127.0	Multi Mode
	M29504/14-4135	142.0	Multi Mode
Socket Termini	M29504/15-4171	126.0	Multi Mode
	M29504/15-4172	127.0	Multi Mode
	M29504/15-4175	142.0	Multi Mode
Crimp Sleeve	-C	Add "-C" at end of part number for Crimp Sleeve, omit for none.	
Dummy Terminus	M29504/3-4038		

Consult factory for additional sizes.



Qualified QPL-29504 pin and socket termini



M28876/11 jam nut receptacle

Terminated and tested MIL-PRF-28876 fiber optic cable assembly



How To Order: Military QPL\*

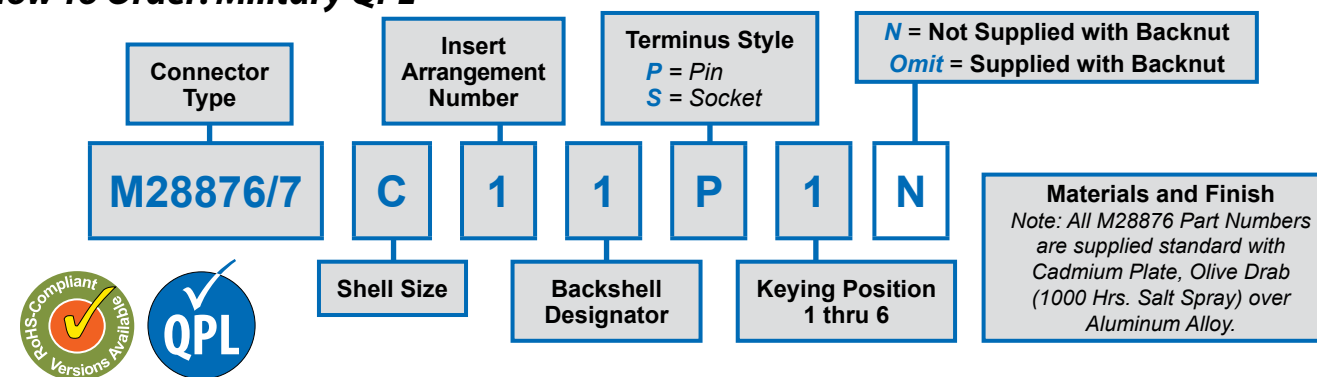

How To Order: Glennair Commercial\*

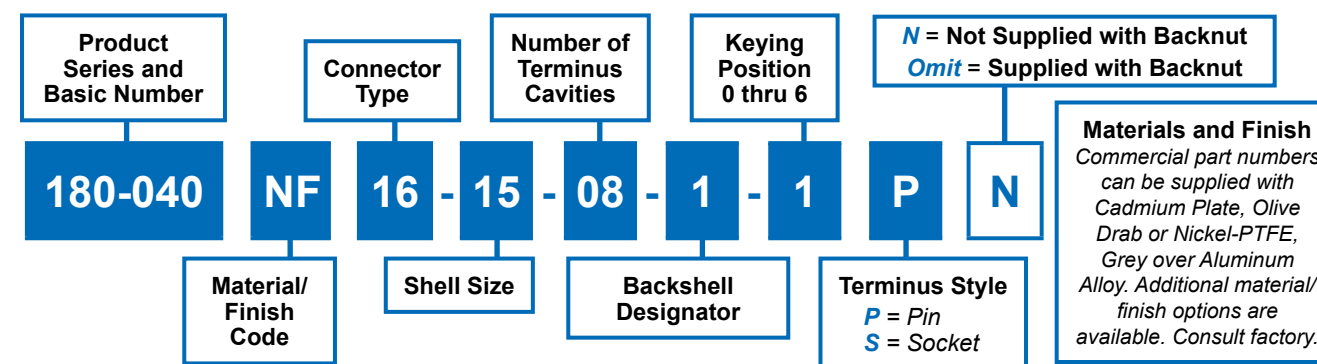

\*See "U.S. Navy Approved Connectors and Accessories" catalog for complete ordering information



## GFOCA M83526 Compliant Fiber Optic Connection System



GFOCA jam nut mount receptacle connector with lanyard-attached dust cover

- 4 channel singlemode and multimode configurations
- Designed IAW MIL-PRF-29504/16 and MIL-DTL-83526/16/ and 17
- Discrete components or complete cable-on-reel solutions available
- Rugged field deployable system
- Corrosion resistant and environmentally sealed
- Low insertion loss 2.5mm diameter genderless butt joint termini
- Ceramic alignment sleeve housed in connector body
- Designed for both low speed analog and high-speed digital data

**The genderless, ruggedized, environmentally-sealed solution for fiber optic battlefield communications—now TFOCA-II® intermateable!**



Turnkey point-to-point and pigtail GFOCA cable assembly

Available Insert Cap Key Configurations	
<p><b>Key 1</b></p>	<p><b>Key 2</b></p>
<p><b>Key 3</b></p>	<p><b>Key "U" (Universal)</b></p>

GFOCA Termini Insertion Loss	
Singlemode	Typical: 0.40dB Maximum: 0.75dB
Multimode	Typical: 0.30dB Maximum: 0.75dB

GFOCA Performance Specifications	
Cable Pull Resistance	400 pounds minimum, 1 hour; applies to plug and strain relief receptacles
Mating Durability	2000 Cycles
Operating Temperature	-46° C to +71° C
Storage Temperature	-55° C to +85° C
Cable Diameter Accommodation	.190" Minimum to .379" Maximum

GFOCA Cable Spool Options	
GFOCA connectors are offered in pre-terminated field-deployable metal spools with M85045 style cable. Customer defined lengths are available up to 2000 meters, with no minimum order quantity.	

TFOCA-II® is a registered trademark of Amphenol Fiber Systems International

## GFOCA M83526 Compliant Fiber Optic Connection System



GFOCA Part Number Reference	
Basic Part Number	Product Description
181-050	Pin Terminus
181-059	Dummy Terminus
180-116*	Plug Connector, Hermaphroditic, 4 Channel
180-117*	Jam Nut Receptacle, 4 Channel
180-125*	Square Flange Receptacle, 4 Channel
180-127*	Jam Nut Receptacle, 4 Ch, Internal Mount

\* Dust Covers supplied with Connectors when indicated in Part Number Development.  
\*\* See fiber optic catalog for complete part number information



Glenair GFOCA M83526 Compliant fiber optic connection system termination, inspection, test, and cleaning tools are available now from Glenair. We also offer comprehensive F/O training services for assembly and maintenance technicians.

Alignment Sleeves for GFOCA Cable Connectors	
Dash Sym	Configuration
M	Solid
S	Split
N	None

Dust Covers for GFOCA Cable Connectors	
Dash Sym	Configuration
H	Hermaphroditic
M	Male
N	None

Alignment Sleeves for GFOCA Jam Nut Mount Receptacles	
Dash Sym	Configuration
M	Solid
S	Split

Dust Covers for GFOCA Jam Nut Mount Receptacles	
Dash Sym	Configuration
F	Female
N	None

Panel Seal Types for GFOCA Jam Nut Mount Receptacles	
Dash No.	Configuration
1	Conductive (EMI)
Omit	Non-Conductive

GFOCA Genderless Termini Part Numbers		
Dash Number	Ø A (Microns)	Fiber Type (Typical)
181-050-1250C	125.5	SM
181-050-1255C	125.5	SM
181-050-1260C	126.0	SM and MM
181-050-1270C	127.0	MM
181-050-1420C	142.0	MM
181-050-2300C	230.0	MM

SM: Singlemode  
MM: Multimode  
Consult Factory for Additional Sizes



## Eye-Beam™ Expanded Beam Fiber Optic Connection System



Eye-Beam™ Expanded Beam fiber optic terminus integrated into ruggedized reverse-bayonet power connectors

**Innovative expanded beam terminus deliver optimal performance in harsh environments**

- All the benefits of an expanded beam connection system built into a versatile F/O terminus
- Factory-terminated F/O Eye-Beam™ terminus easily integrated into any connector package
- Innovative expanded beam lens terminus expands signal 27X from a standard 9.3 micron fiber core
- Revolutionary design delivers low dB loss (1.5 dB multimode, 2.0 dB singlemode untuned) performance while reducing maintenance, inspection and test costs
- Ultra-high precision ceramic sleeves and custom designed terminus bodies ensure perfect axial alignment



Eye-Beam™ Expanded Beam fiber optic terminus can be integrated into virtually any circular or rectangular connector package



### Butt-Joint Fiber Optic Terminus

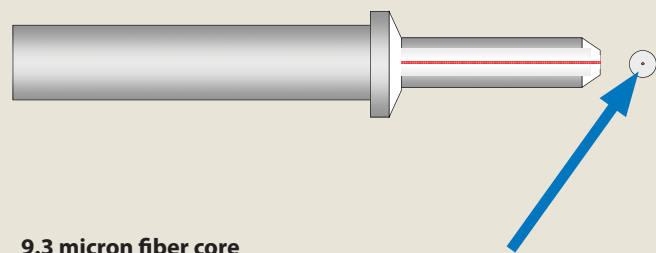

9.3 micron fiber core  
Fiber surfaces exposed and susceptible to damage  
Must be cleaned prior to mating

### Eye-Beam™ Expanded Fiber Optic Terminus

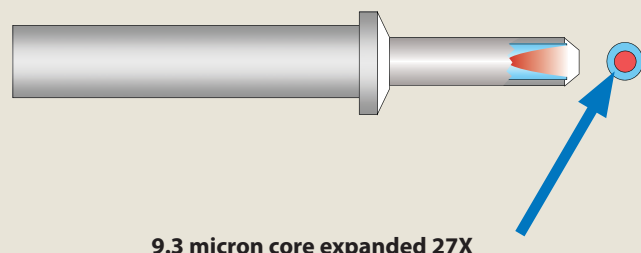

9.3 micron core expanded 27X  
Fiber surfaces protected from contamination  
Easy clean lens surface

## Eye-Beam™ Expanded Beam Fiber Optic Connection System



### How To Order factory terminated Eye-Beam™ pigtails and jumpers

1. Eye-Beam™ system part numbers begin with the FA1000 Basic Part Number
2. Select fiber size (Consult factory for additional options)
3. Select operating wavelength
4. Select pigtail or jumper cable configuration. Pigtails and jumpers are supplied standard with 36 inches of fiber cable. Specific lengths available in part number breakdown as shown below.

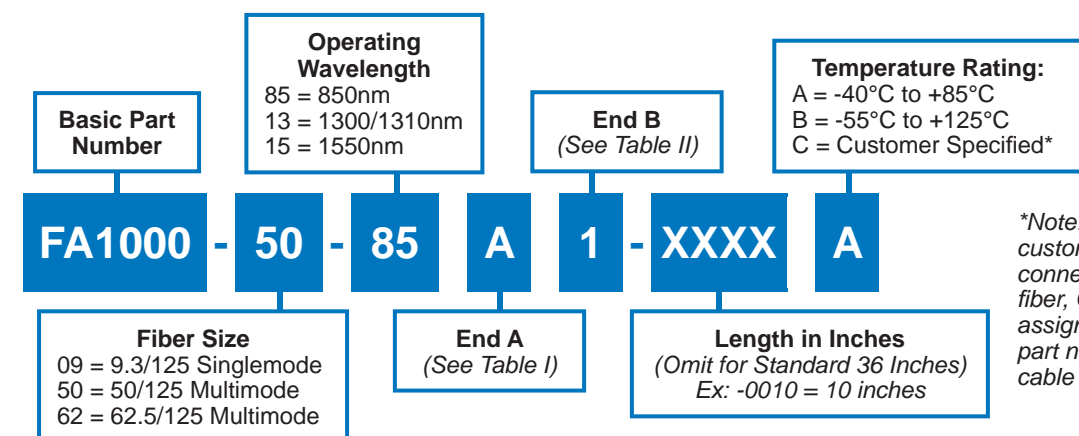

Designator	Description	Connector Series
A	M29504/4 Style Pin (181-070)	MIL-DTL-38999
B	M29504/5 Style Socket (181-071)	MIL-DTL-38999
C	M29504/14 Style Pin (181-XXX)	MIL-PRF-28876
D	M29504/15 Style Socket (181-XXX)	MIL-PRF-28876
E	Mighty Mouse Pin (181-XXX)	Series 80 Mighty Mouse
F	Mighty Mouse Socket (181-XXX)	Series 80 Mighty Mouse
G	GFR Pin (181-XXX)	Glenair GFR System
H	GFR Socket (181-XXX)	Glenair GFR System
J	GFOCA Termini (181-067)	GFOCA (hermaphroditic)

A	M29504/4 Style Pin (181-070)
B	M29504/5 Style Socket (181-071)
C	M29504/14 Style Pin (181-XXX)
D	M29504/15 Style Socket (181-XXX)
E	Mighty Mouse Pin (181-XXX)
F	Mighty Mouse Socket (181-XXX)
G	GFR Pin (181-XXX)
H	GFR Socket (181-XXX)
J	GFOCA Termini (181-067)
1	LC Connector
2	LC APC Connector
3	FC Connector
4	FC APC Connector
5	ST Connector
6	SC Connector
7	SMA 905 Connector
8	SMA 906 Connector
9	Customer Specified*



Factory terminated lens pin terminus and lens socket terminus on pigtail wires allow for easier fusion splicing in the field.

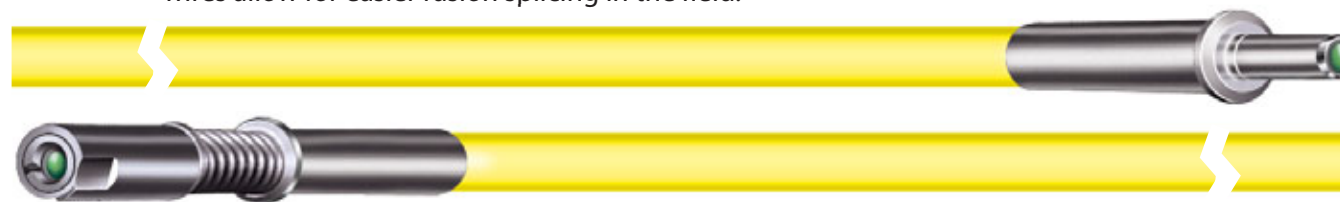



## Copper-to-Fiber Media Converters/ Active Components

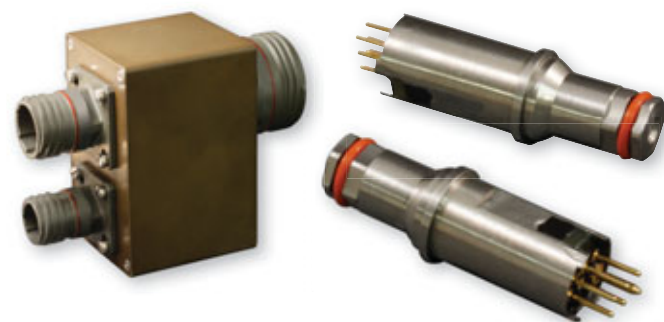

**Small form-factor copper to fiber media converters reduce weight and complexity in fiber optic interconnect systems**

### Size #8 Optoelectronic Insert Transmitter and Receiver



Product Series

050 - 301

#8 Optoelectronic  
Insert

- ARINC 664, 801, 803, 804, and 818 standard Compliant
- Data rates from 125Mbps to 3.8 Gbps for Transmitter, 125Mbps to 4.25Gbps for Receiver
- Supports Fast and Gigabit Ethernet, AFDX, 1x/2x Fibre Channel, DVI, HDMI, SFPDP, Serial Rapid I/O (sRIO).
- Designed for harsh environment applications.
- Operating temperature range of -40°C to +85°C
- Transmitter: 100 ohms differential CML inputs with TX Fault and TX Disable
- Receiver: 100 ohms differential CML Outputs with Loss Of Signal indicator (LOS)
- Works with Multimode 50/125uM or 62.5/125 uM fiber
- Link distance of up to 550 Meters with Multimode 50/125uM fiber
- Single 3.3v power supply
- ARINC 801 1.25mm/2.5mm ceramic fiber ferrule, or expanded beam

Absolute Maximum Rating					
Parameter	Symbol	Minimum	Typical	Maximum	Unit
Storage Temperature	T <sub>s</sub>	-55		+100	°C
Operating Voltage	V <sub>cc</sub>	-0.4		+4	V

Operating Conditions					
Parameter	Symbol	Minimum	Typical	Maximum	Unit
Operating Temperature	T <sub>op</sub>	-40		+85	°C
Supply Voltages	V <sub>cc</sub>	3.14	3.3	3.46	V
Power Supply Noise	V <sub>cc</sub> Ripple			0.15	V

Power Supply Current V <sub>cc</sub> = 3.14 to 3.46V					
Parameter	Symbol	Minimum	Typical	Maximum	Unit
Supply Current	I <sub>cc</sub>			70	mA



Optical Transmitter						
Parameter	Symbol	Minimum	Typical	Maximum	Unit	
Optical Sensitivity		-17			dBm	
125Mbps-1.25Gbps		-15			dBm	
2.12Gbps-3.2Gbps		-14			dBm	
3.2Gbps-4.25Gbps					dBm	
Optical Overload				0	dBm	
Optical Wavelength	λ <sub>out</sub>	830		860	nm	
Differential Output Swing (P-P)	V <sub>diff</sub>	600		1200	mV	
LOS Assert Level	LOS <sub>h</sub>	-22			dBm	
LOS Hysteresis	LOS <sub>HYS</sub>	1.5	2.3		dB	

## Copper-to-Fiber Media Converters/ Active Components



### Series 050-201 DVI Copper to Fiber Media Converter



- -40°C to +85°C operating temperature range
- Meets MIL-STD-810 shock and vibration, and MIL-STD-1344 immersion
- Fiber link distance of up to 320 meters with 50/125 um multimode fiber (500 MHz km fiber)
- Fiber connector interface compatible with MIL-T-29504
- D38999 circular connector with quadrx electrical interface for RGB and Clock
- TMD5 compatible electrical interface
- MIL-STD-1560 standard layouts for electrical and fiber optic connectors
- Available options for fiber receptacle compatible with: 1.25mm, 1.57mm, 2mm, and 2.5mm ferrules sizes.
- Made-to-order packaging and connector options available

Military Specification Compliance			
Feature	Standard	Condition	Notes
ESD	MIL-STD-883	Class II	2200V
Shock	MIL-STD-810	40g	6-9mS
Vibration	MIL-STD-810	40g RMS	

Power Supply 18V to 36 V			
Parameter	Symbol	Maximum	Unit
Power Supply Current	ICC	200	mA

Optical Transmitters					
Parameter	Symbol	Minimum	Typical	Maximum	Unit
Optical Output Power	P <sub>O</sub>	-6.0	-4	-1	dBm
Optical Output Wavelength	λ <sub>OUT</sub>	830	850	860	nM
Spectral Width(RMS)	Δλ			.85	nM
Extinction Ratio	ER	9.0			dB

Optical Receivers					
Parameter	Symbol	Minimum	Typical	Maximum	Unit
Optical Input Power	PI	-19.0		0	dBm
Optical Input Wavelength	λ <sub>IN</sub>	830	850	860	nM

### Series 050-101 1000BASE-T to 1000BASE-SX/LX Media Converter



- IEEE 802.3-2005 Gigabit Ethernet standard compliant
- -40°C to +85°C operating temperature range
- Ideal for military and other harsh environment applications.
- Meets MIL-STD-810 Mechanical Shock and Vibration
- Meets Mil-STD-1344 immersion resistance
- MIL-STD-1560 standard layouts for both electrical and fiber optic connectors
- Available options for fiber receptacle compatible with: 1.25mm, 1.57mm, 2mm, and 2.5mm ferrules sizes.
- Single power supply operation from 5V to 36V, with optional 3.3V version.
- Made-to-order packaging and connector options available

Optical Link Distances		
Protocol	Fiber Type	Distance
1000BASE-SX, 850nm VCSEL	62.5/125µm, 200MHZ*Km	275 Meters
	50/125µm, 500MHZ*Km	550 Meters
1000BASE-LX, 1310nm FP	9/125 µm	10 Kilometers

Military Specification Compliance			
Feature	Standard	Condition	Notes
Shock	MIL-STD-810	40g	6-9ms
Vibration	MIL-STD-810	30g RMS	18ms
ESD	MIL-STD-883	Class II	2200v
Durability	MIL-STD-38999/20	500 Cycles	<0.5 db change

**NEXT GENERATION**

# SHRINK BOOTS JACKETS AND SHIELDS

**FOR EXTREME ENVIRONMENTAL AND EMI/RFI PROTECTION**



Cable assemblies, exposed to harsh environmental, mechanical and electromagnetic stress are routinely equipped with boots, shields, and jackets designed to protect critical circuits from damage. Glenair offers a complete, turnkey solution to cable and conduit protection that includes innovative lightweight braided EMI/RFI shielding, revolutionary Duralectric™ jacketing, and our full spectrum Series 77 Full Nelson environmental shrink boot product family.



GLENAIR, INC. • 1211 Air Way • Glendale, CA 91201-2497 • Tel: 818-247-6000 • Email: sales@glenair.com • www.glenair.com



**Series 77 Full Nelson  
Environmental  
Shrink Boots**



**ArmorLite™ Micro  
Stainless Steel and  
AmberStrand®  
Composite  
EMI/RFI  
Braided Shielding**

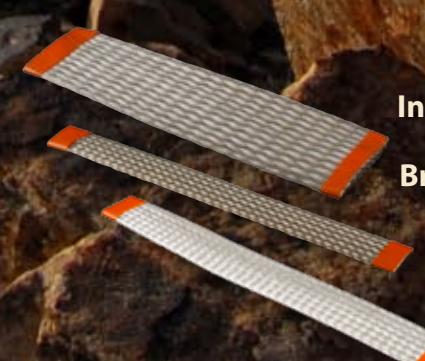

**Industry Standard  
EMI/RFI Metal  
Braided Shielding  
and Sleeving**



**Duralectric™, Viton®,  
and other  
Cable and Conduit  
Jacketing**



**Standard Lipped  
or Lipless Boots**
**Transitions**
**Convoluted  
Boots**

**Outstanding mechanical and environmental protection/strain relief for connector-to-cable transitions**

- Standard, short, long and 90° lipped and lipless boots
- Choice of six boot materials and a complete range of high-performance adhesive types
- A wide range of colors including desert tan
- The industry's largest selection of metal and composite shrink boot adapters
- All popular part numbers in stock and ready for same-day shipment

**Shrink Boot Adapters Selection Guide**

**Series 310  
Shrink Boot  
Adapters**
**Series 311  
EMI/RFI Lamp-Base  
Thread/Boot Adapters**
**Series 319  
Shield Sock/Boot  
Adapters**
**Series 440  
Band/Boot  
Adapters**
**SAE-AS85049 QPL  
Shrink Boot  
Adapters**
**Composite  
Thermoplastic  
Band/Boot Adapters**
**Material Color Options for Type 1 High Performance Elastomer Only  
Add Optional Color Mod Code to End of Any Type 1 Material Part Number**

Mod Code	Color	Similar to (Reference)	Mod Code	Color	Similar to (Reference)
632 B	Blue	PANTONE 3005U	632 R	Red	PANTONE 1797U
632 E	Grey	FED-STD-595; #36270	632 T	Tan	FED-STD-595; #33446
632 G	Green	PANTONE 355U	632 W	White	FED-STD-595; #37875
632 P	Purple	FED-STD-595; #37100	632 Y	Yellow	PANTONE YELLOW U
632 O	Orange	FED-STD-595; #32300	Standard	Black	FED-STD-595; #37038

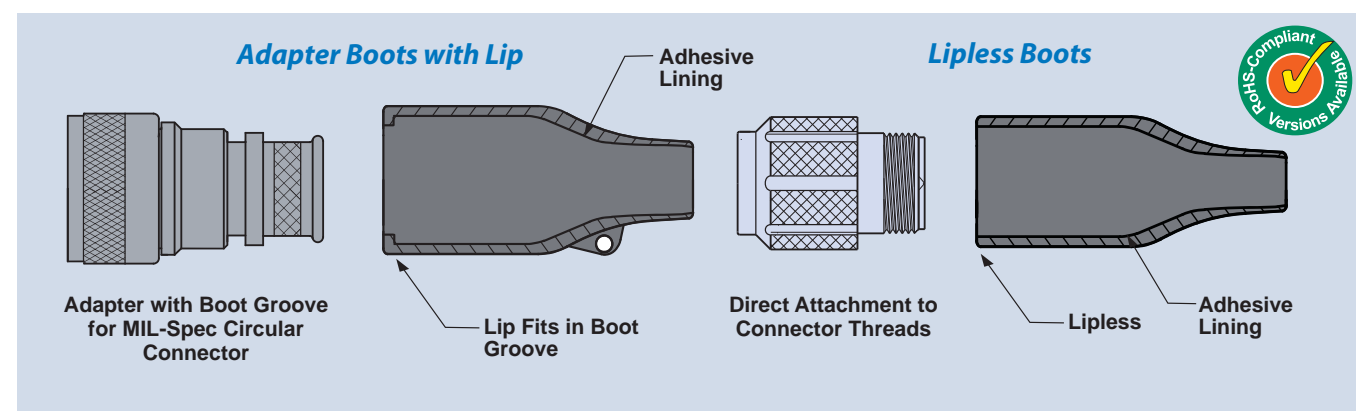
**Shrink Boot Typical Material Properties**

Property	Type 1 High Performance Elastomer	Type 2 Zero Halogen Polyolefin	Type 3 General Purpose Polyolefin	Type 5 Viton® Fluoroelastomer Blend	Type 6 High Performance Elastomer Alloy	Type 7 Flexible Polyolefin
Flexibility	Semi-rigid	Semi-flexible	Flexible	Flexible	Flexible	Highly Flexible
Operating Temperature Range	-75°C to +150°C	-30°C to +135°C	-55°C to +135°C	-55°C to +150°C	-55°C to +135°C	-55°C to +135°C
Shrink Temperature (min.)	135°C	135°C	120°C	135°C	135°C	135°C
Tensile Strength (psi)	1700	1100	1400	2200	1500	1400
Elongation (% min.)	400	250	400	400	300	250
Long Term Heat Aging	3000 hrs, 150°C	3000 hrs, 135°C				
Heat Shock	4 hrs, 215°C	4 hrs, 215°C	4 hrs, 225°C	4 hrs, 225°C	4 hrs, 220°C	4 hrs, 250°C
Heat Aging	168 hrs, 160°C	168 hrs, 160°C	168 hrs, 175°C	168 hrs, 150°C	168 hrs, 150°C	168 hrs, 175°C
Dielectric Strength (V/mil)	300	380	250	200	200	300
Volume Resistivity (ohm-cm)	10 <sup>13</sup>	10 <sup>12</sup>	10 <sup>12</sup>	10 <sup>10</sup>	10 <sup>10</sup>	10 <sup>12</sup>
Water Absorption (%)	0.5	0.5	0.5	0.5	0.5	0.5
Flammability	Burn Time <15 sec Burn Length <25mm	Burn Time <15 sec Burn Length <25mm	Burn Time <120 sec Burn Length <25mm	Burn Time <120 sec Burn Length <25mm	Burn Time <120 sec Burn Length <25mm	Burn Time <90 sec Burn Length <25mm
RoHS Compliant	Yes	Yes	Yes	Yes	Yes	Yes
Oxygen Index (% min.)		30				
Temperature Index (°C)		250				
Smoke Index (max.)		20				
Toxicity Index (max.)		3				

**Series 77 Shrink Boots Product Selection Guide**



## Duraelectric™, Viton® and other Cable and Conduit Jacketing



Rugged  
environmental  
jacketing in a  
broad range of  
material types  
and colors

- Extruded, blown-on and heat shrink jacketing for harsh application environments
- General purpose polyurethane
- Low-smoke, zero halogen Duraelectric™
- Chemically-resistant Viton®
- Industry standard neoprene
- Selected materials CBRN tested

**High-performance cable and conduit jacketing materials purpose-designed for every application requirement: Immersion, chemical or caustic fluid exposure, temperature extremes, UV radiation and more**



### Jacketing Options

Option	Material	Description
N	Neoprene	Tough, durable polychloroprene for mechanical and environmental protection
H	Hypalon®	Light weight with broad temperature range
E	EPDM	Better resistance to Ketones
V	Viton®	Heaviest material with best resistance to oil and gasoline
B	Duraelectric™, Black	Weatherproof, halogen free, flame resistant, functional to 260°C
G	Duraelectric™, Gray	Qualified to US Navy MIL-PRF-24758A, Fed Std 595B #26270 Haze Gray color
TN	Duraelectric™, Desert Tan	Duraelectric™ in Fed Std #3446 Desert Tan color
O	Duraelectric™, Orange	OSHA Safety Orange to mark energized electrical cables

### Jacketing Material Properties and Chemical Resistance

Material Property	EPDM (Ethylene Propylene Diene Monomer)	Hypalon (Chlorosulfonated Polyethylene)	Neoprene (Polychloroprene)	Viton® (Fluoroelastomer)	Duraelectric™
Temperature Range	-60°F to +300°F (-51°C to +149°C)	-60°F to +300°F (-51°C to +149°C)	-60°F to +250°F (-51°C to +121°C)	-40°F to +392°F (-40°C to +200°C)	-94°F to +392°F (-70°C to +200°C)
Specific Gravity	1.26	1.18	1.25	1.80	1.22
Weight: Lbs./Cubic Inch	.045	.043	.045	.055	.045
Abrasion Resistance	Excellent	Excellent	Excellent	Excellent	Good
Wear Resistance	Good	Good	Good	Good	Good
Flame Resistance	Good	Good	Good	Good	Excellent
Sunlight Resistance	Good	Excellent	Excellent	Excellent	Excellent
Chemical Resistance					
Aliphatic Hydrocarbons	Good	Good	Good	Excellent	Excellent
Aromatic Hydrocarbons	Good	Fair	Fair	Excellent	Excellent
Ketones, Etc.	Good	Poor	Poor	Poor	Excellent
Oil & Gasoline	Good	Good	Good	Excellent	Excellent

## Duraelectric™, Viton® and other Cable and Conduit Jacketing



Glenair *Duraelectric™* weatherproof jacketing is halogen free, flame resistant, and functional to 260°C. *Duraelectric™* far surpasses the accelerated solar weathering standards under IEC 60068-2-5, and is tested to 56 accelerated days, equivalent to 53 years of solar exposure. Glenair can supply the material in a variety of formats, including blown jacketing, as an extrusion over wire and cable, as an overmolding compound and as a self-vulcanizing repair tape.

### Glenair Duraelectric™ Material Specifications

Temperature rating: -70°C to +200°C (with excursions to 260°C)

Halogen free per IEC 60614-1. Less than 5mg of hcl per 1 gm of product tested.

Accelerated Weathering (Solar) per IEC 60068-2-5; 56 days exposure

Flame Resistant per IEC 60614-1; Material does not sustain combustion when the source of flame is removed.

Low Smoke Index per NES 711 (11.75); Minimum standard is 25. The Glenair tested level is 11.75. This makes the material acceptable for interior applications as well as topside.

Smoke Density Class F1 Per NF F 16-101 IAW DIN EN 60695-2-11:2001

Toxicity Index per NES 713 (1.9); Minimum standard is 5. The Glenair tested level is 1.9. This makes the material acceptable for interior applications as well as topside.

Colorable to Fed Std 595B

Markable IAW MIL-PRF-24758A

Oxygen Limiting Index = 45.1 Per EN ISO 4589-2:1999; Minimum is 28.

### 12 Sec Vertical Burn: (Pass) Per 14CFR Part 25.853(a) amdt 25-116 App F Part 1 (a)(1)(ii)

Fluids Per MIL STD 810F, Method 504	Cleaner (MIL-C-85570): CALLA-855
Fuel (MIL-T-83133): JPG	Solvent (Isopropyl Alcohol): TT-I-735
Fuel (MIL-T-83133): JPG	De Icer (AMS-1432): E36 Runway Deicer
Hydraulic Fluid (MIL H 5606): ROYCO 756	Coolant (MIL-C-87252): Coolanol 25R
Lube Oil (MIL-L-23699): ROYCO-500	Fire Extinguishant Foam: AMEREX AFFF

**MASTER SEAL** Self-Vulcanizing Sealing Tape

GLENAIR PART NO.  
**687-758**

*Duraelectric™ material sealing tape designed for temporary repair of cable and conduit. Glenair Master Seal effectively stops water incursion until a permanent repair can be made.*

# AmberStrand®

- Metal-clad EMI/RFI Shielding with a lightweight composite thermoplastic base material
- Highly conductive surface plating
- Reduce shielding weight up to 80% and more
- Reduce operation costs by permanently reducing launch and aircraft all-up weights
- Superior high frequency shielding compared to tinned and/or nickel plated copper
- Exceptional tensile strength: 590,000 psi (min)

AmberStrand® is ultra-lightweight microfilament metal clad EMI/RFI composite braiding

## AmberStrand®: The smart way to reduce launch and flight weights in aerospace systems

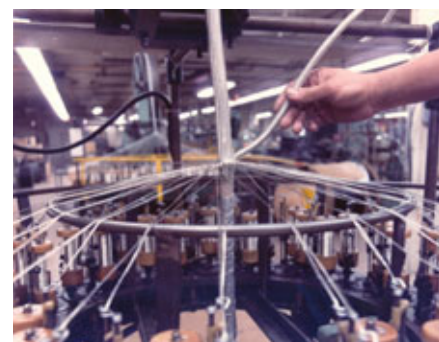

Composite strain-relief backshell with integrated AmberStrand® lightweight composite metal-clad braided shield sock.

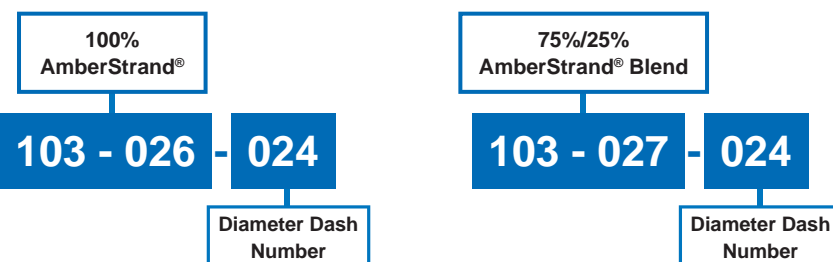

Glenair can also offer AmberStrand® users direct factory overbraiding services for both point-to-point as well as multi-branch interconnect assemblies.

### How does Amberstrand® compare, in terms of mechanical performance, to other materials?

Material Type	AmberStrand® Thermoplastic	PEEK (Monofil)	Teflon (Yarn)	Kevlar (Yarn)	Dacron (Yarn)	Halar (Monofil)	Teflon FEP (Monofil)	Nomex (Yarn)	Polyester Type FR (Monofil)	Ryton Type R-7 (Monofil)	PTFE-Glass (Yarn)
Glenair P/N	103-026 103-027	102-051	102-061	102-071	102-073	102-023	102-060	103-013	102-001 102-002	102-080	100-022
Temperature Range	-65°C to +200°C	-65°C to +260°C	-55°C to +200°C	-73°C to +175°C	-62°C to +150°C	-65°C to +200°C	-55°C to +260°C	-55°C to +125°C	-55°C to +200°C	-65°C to +200°C	-75°C to +525°C
Tensile Strength (PSI) Yield	590,000	780,000	40,000	400,000	160,000	35,000	14,000	90,000	50,000	19,000	450,000
Elongation Percentage	2.5%	38%	19%	3.6%	12%	15%	50%	25%	20%	35%	5%
Chemical Resistance	Excellent	Excellent	Excellent	Excellent	Good	Excellent	Excellent	Excellent	Good	Excellent	Excellent
Abrasion Resistance	Good	Excellent	Good	Good	Excellent	Excellent	Good	Good	Good	Excellent	Excellent
Specific Gravity	1.45	1.30	2.10	1.44	1.38	1.68	2.17	1.58	1.38	1.25	2.50
Flammability	Will Not Burn	Very Low	Will Not Burn	Will Not Melt	Flammable	Flammable	Very Low	Will Not Melt	Very Low	Very Low	Will Not Burn

### Aircraft Utilization Analysis

Comparison of AmberStrand® Composite EMI/RFI braid to 36 AWG A-A-59569 Ni/Cu Braid results in 60+ pounds weight savings in a typical commercial carrier

#### Where is all the EMI/RFI braid deployed in a typical commercial aircraft?

Diameter (in)	L Wing	R Wing	Fwd Belly	Aft Belly	HYD Bay	Aft Barrel	Tail	V/H Stab	Totals (in)
0 - 0.25	1852.2	1852.2	0	2811.4	168.2	2015.2	2480.6	1385	12564.8
0.25 - 0.5	434.8	434.8	511.6	1034.6	257.4	506.2	958.2	1121.7	5259.3
0.5 - 0.75	0	0	260.9	223	0	184.2	392.4	152.1	1212.6
0.75 - 1.0	0	0	77.2	0	0	1198	162.2	0	1437.4
1.0 - 1.5	0	0	0	0	0	446	21	0	467

#### How much would all this braid weigh if it was made of 36 AWG A-A-59569 NiCu?

Diameter (in)	Weight (Lb/ft)	Length (in)	Weight (Lb)
0 - 0.25	0.02	12564.8	21.08
0.25 - 0.5	0.05	5259.3	21.17
0.5 - 0.75	0.07	1212.6	7.12
0.75 - 1.0	0.14	1437.4	16.88
1.0 - 1.5	0.18	467	7.05
<b>Total weight</b>			<b>73.30 lbs</b>

#### How much would all this braid weigh if it was made of lightweight composite AmberStrand®?

Diameter (in)	Weight (Lb/ft)	Length (in)	Weight (Lb)
0 - 0.25	0.003	12564.8	4.16
0.25 - 0.5	0.008	5259.3	3.58
0.5 - 0.75	0.011	1212.6	1.16
0.75 - 1.0	0.018	1437.4	2.11
1.0 - 1.5	0.034	467	1.30
<b>Total weight</b>			<b>12.31 lbs</b>

#### Expressed in percentages, how does 100% and 75% metal clad AmberStrand® compare against tin-coated copper?

Braid Diameter	AmberStrand® 100% 103-026	Tinned Copper 100-001	% Weight Savings/Foot	AmberStrand® 75/25 NiCu% 103-027	Tinned Copper 100-001	% Weight Savings/Foot
.062	.6	1.9	68%	.9	1.9	52%
.125	1.0	4.8	79%	1.5	4.8	68%
.250	1.8	16.1	88%	2.4	16.1	85%
.375	2.3	18.5	87%	3.9	18.5	79%
.500	3.7	22.3	83%	5.4	22.3	76%
.625	4.4	27.7	84%	6.4	27.7	77%
.750	5.2	34.3	85%	7.2	34.3	79%
1.000	8.0	35.0	77%	11.0	35.0	69%

### 103-031 AmberStrand® Lightweight Metal-Clad Spooled Fiber

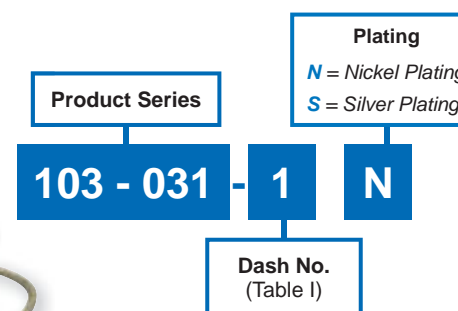

Part Number	Spool Specification
103-031-1	Single End Spooled 3000 FT. Per Spool
103-031-2	Double End Spooled 1250 FT. Per Spool
103-031-3	Three End Spooled 833 FT. Per Spool
103-031-4	Four End Spooled 625 FT. Per Spool
103-031-5	Double End Spooled 500 FT. Per Spool
103-031-6	Six End Spooled 400 FT. Per Spool



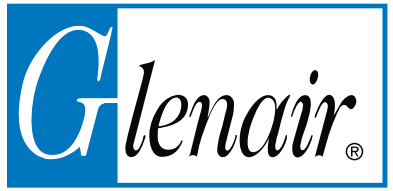

## ArmorLite™ Microfilament Nickel Clad Stainless Steel EMI/RFI Braided Shielding



- Ultra-lightweight EMI/RFI braiding for high-temperature applications -80°C to +260°C
- Microfilament stainless steel: 70% lighter than NiCu A-A-59569
- Outstanding EMI/RFI shielding and conductivity
- Reduce shielding weight up to 70% and more
- Superior flexibility and "windowing" resistance: 90 to 95% optical coverage
- 220,000 psi (min) tensile strength
- Best performing metallic braid during lightning tests (Run to ANSI/EIA-364-75-1997 Waveform 5B)

**Save weight and money every time you fly! Aircraft All-Up-Weight (AUW) has met its match: ArmorLite™ microfilament stainless steel braid saves pounds compared to standard QQ-B-575/A-A-59569 EMI/RFI shielding.**



Choose user-installable microfilament tubular braid in twelve standard diameters Assemble per standard multi-branch cable shielding processes, as above.

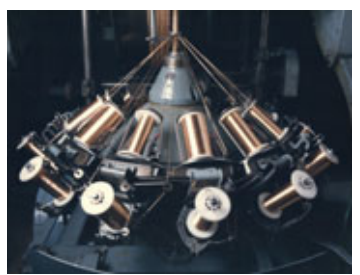

Glenair can also offer ArmorLite™ users direct factory overbraiding services for both point-to-point as well as multi-branch assemblies.

100% ArmorLite™

103 - 051 - 024

Diameter Dash Number



**A single layer of ArmorLite™ Shields from 40dB to 80dB in Frequency Ranges from 30kHz to 2.5GHz**

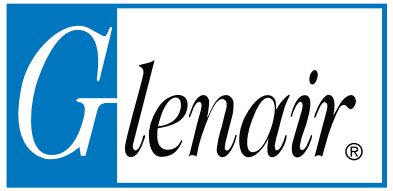

## ArmorLite™ Microfilament Nickel Clad Stainless Steel EMI/RFI Braided Shielding

### Aircraft Utilization Analysis

Comparison of ArmorLite™ nickel clad stainless steel braid to A-A-59569 Ni/Cu braid

Where is all the EMI/RFI braid deployed in a typical commercial aircraft?

Diameter (in)	L Wing	R Wing	Fwd Belly	Aft Belly	HYD Bay	Aft Barrel	Tail	V/H Stab	Totals (in)
0 - 0.25	1852.2	1852.2	0	2811.4	168.2	2015.2	2480.6	1385	12564.8
0.25 - 0.5	434.8	434.8	511.6	1034.6	257.4	506.2	958.2	1121.7	5259.3
0.5 - 0.75	0	0	260.9	223	0	184.2	392.4	152.1	1212.6
0.75 - 1.0	0	0	77.2	0	0	1198	162.2	0	1437.4
1.0 - 1.5	0	0	0	0	0	446	21	0	467

How much would all this braid weigh if it was made of 36 AWG A-A-59569 NiCu?

Diameter (in)	Weight (Lb/ft)	Length (in)	Weight (Lb)
0 - 0.25	0.02	12564.8	21.08
0.25 - 0.5	0.05	5259.3	21.17
0.5 - 0.75	0.07	1212.6	7.12
0.75 - 1.0	0.14	1437.4	16.88
1.0 - 1.5	0.18	467	7.05
		<b>Total weight</b>	<b>73.30 Lbs</b>

How much would all this braid weigh if it was made of ArmorLite™ Micro Stainless Steel Braided Shielding?

Diameter (in)	Weight (Lb/ft)	Length (in)	Weight (Lb)
0 - 0.25	.00507	12564.8	5.309
0.25 - 0.5	.0097	5259.3	4.251
0.5 - 0.75	.0178	1212.6	1.737
0.75 - 1.0	.0256	1437.4	3.063
1.0 - 1.5	.0368	467	1.434
		<b>Total weight</b>	<b>15.794 Lbs</b>



The lightest ground straps in the industry: Silver or nickel plated

- Thermal Cycling: No Adverse Effects
- Flame: Self Extinguishing
- Flex Test: 50,000 Cycles
- Salt Spray: 500 Hours
- 70+% Lighter than NiCu QQ-B-575/A-A-59569
- Enhanced EMI/RFI Electrical Performance (DC resistance 1 Ohm/ft).

### Shielding Effectiveness For EMI/RFI Braiding Solutions - 0 MHz to 2500 MHz Range

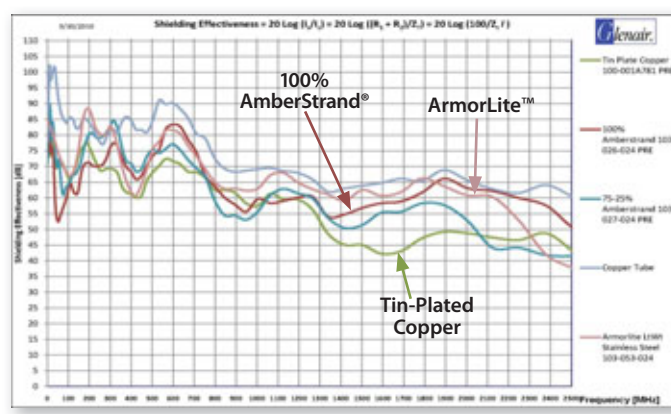

### Surface Transfer Impedance For EMI/RFI Braiding Solutions - 0 MHz to 2500 MHz Range

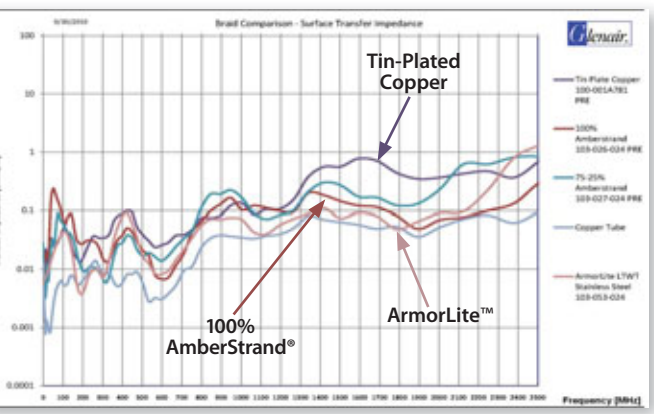



- Complete range of QQ-B-575B/A-A and ASTM B conductive braided shielding solutions
- Tubular, tapered tubular, and overbraided application options
- Every size from 1/32" to 3 3/4"
- High performance tubular fabric braided sleeving for every mechanical and wire-protection application requirement

## World's largest selection of metal and fabric cable shields

### 100-001 Tubular Metal Braid QQ-B-575B/A-A-59569 ASTM B33 Tin Coated Copper

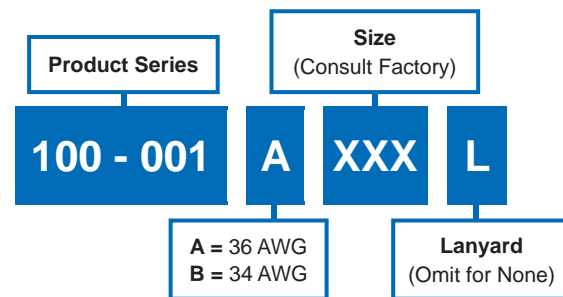
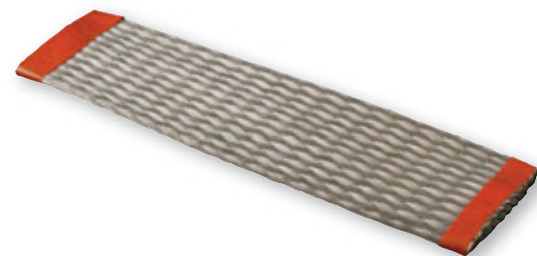

### 100-002 Tubular Metal Braid QQ-B-575B/A-A-59569 ASTM B33 Silver Coated Copper

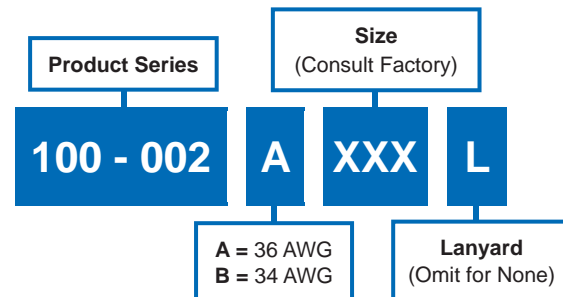

### 100-003 Tubular Metal Braid ASTM B355 Class 4 OFHC Nickel Plated Copper

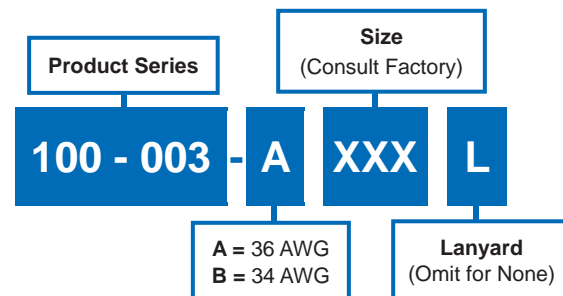

### 100-041 Tapered Tubular Metal Braid, AmberStrand®, ArmorLite™ Nickel/Copper, Silver/Copper or Tin/Copper



A = 100% AmberStrand®  
B = 75%/25% AmberStrand®  
L = 100% ArmorLite™  
N = Nickel/Copper  
S = Silver/Copper  
T = Tin/Copper

A = 36 AWG  
(Omit for Std.  
34 AWG)

Product Series

100 - 041

- 06

N

5

A

Size  
(Consult Factory)Length  
(in 1 inch increments)

Fabric braided sleeving  
for non-environmental  
wire and cable  
protection

#### Non-Environmental Fabric Braided Sleeving Types

Series No.	Type
100-022	PTFE glass tubular braided sleeving
102-001 and -002	Polyethylene expandable fabric tubular braided sleeving; black, green, red, white, and yellow
102-020, -021, -022 and -023	Halar expandable fabric tubular braided sleeving, white or black, with and without tracers
102-073	Dacron tubular braid, black
103-013	Nomex tubular braid; black, white, red, green, gray, and desert tan
102-051	PEEK tubular braid, black
102-061	Teflon tubular braid, clear and natural
102-071	Kevlar tubular braid, natural
102-072	Nylon tubular braid, black

### Factory overbraiding services for multi-branch cable assemblies



Glenair operates one of  
the largest multi-spindle  
overbraiding operations  
in the world



**SERIES 72, 74, AND 75**

# METAL AND POLYMER CORE CONDUIT SYSTEMS

THE FLEXIBLE, LIGHTWEIGHT ALTERNATIVE TO STANDARD JACKETED CABLES

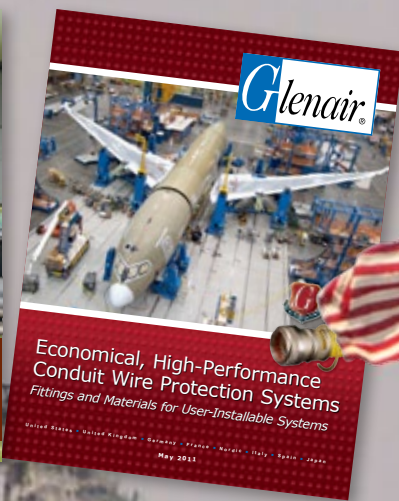

Conduit systems are ideally suited when wire protection requirements do not allow the specification of standard jacketed and shielded cabling. Jet aircraft landing gear applications, for example, require greater flexibility and mechanical protection against impact damage than is possible to provide in even the most aggressively armored cables. Glenair metal-core and polymer-core conduit systems provide superior electromagnetic compatibility, flexibility, and ease-of-installation and maintenance compared to standard-jacketed cables. Choose from turnkey factory-terminated systems or convenient user-installable fittings and materials.



GLENAIR, INC. • 1211 Air Way • Glendale, CA 91201-2497 • Tel: 818-247-6000 • Email: sales@glenair.com • www.glenair.com



Series 72 Annular Polymer-Core Conduit Systems



Series 74 Helical Polymer-Core Conduit Systems



Series 75 Metal-Core Conduit Systems



MIL-PRF-24758 Navy Shipboard and Other Special Purpose Conduit System



Turnkey Factory Terminated Assemblies



## Series 72 Annular Polymer-Core Conduit Systems



Standard Black and Natural/  
Clear Annular  
Tubing

Blue, Yellow, Red, Desert  
Tan, and Orange Annular  
Polymer-Core Tubing

- **Lightweight, flexible polymer-core materials and easy to install fittings, transitions and adapters**
- **Choice of three tubing material choices: Kynar, PVDF and G-FLEX Siltem**
- **A wide range of colors including desert tan**
- **Choice of turnkey, factory-terminated assemblies or user-installable configurations**
- **All popular part numbers in stock and ready for same-day shipment**

**High-performance annular convoluted tubing provides an economical, lightweight and durable enclosure for interconnect wiring**

**Part Number  
120-144**



### **For non-environmental and non-EMI/RFI applications**

Strong, abrasion resistant annular conduit tubing, supplied in thermally stabilized Kynar®, PVDF, or medium duty Siltem. Available in 7 colors, standard or slit.

**Part Number  
121-190**



### **For non-environmental EMI/RFI applications**

Annular conduit tubing with braided shield for EMI/RFI protection and additional structural integrity, particularly pull (tensile) strength.

**Part Number  
121-191**



### **For environmental EMI/RFI applications**

Annular conduit tubing with braided shielding for EMI/RFI protection and a ruggedized jacket for environmental protection against dust, dirt, and moisture incursion.

**Part Number  
121-192**



### **For non-environmental EMI/RFI applications with high dB shielding requirements**

Annular conduit tubing with double braided shield for high frequency EMI/RFI protection and mechanical strength.

**Part Number  
121-193**



### **For environmental EMI/RFI applications with high dB shielding requirements**

Annular conduit tubing with double braided shield and jacket for optimum EMI/RFI protection, strength and environmental sealing.



## Series 72 Annular Polymer-Core Conduit Systems

### Tubing Material Choices

Y	Kynar®	Flexible, thermally stabilized, resistant to harsh chemicals and radiation. UV resistant, self-extinguishing, nontoxic and resistant to low-temperatures. 166° C temp. rating.
V	PVDF	Flexible and chemical/radiation resistant. Available in 4 colors plus standard black and natural. 150° C temperature rating.
S	G-FLEX Siltem	Lightweight, halogen-free, low toxicity, low smoke. Exceptional flexibility and crush resistance. 175°C temperature rating. Ideal for harsh environment applications.

### Material Properties - Kynar® and PVDF

Material Property	Service Temperature	Tensile Strength	Elongation	Specific Gravity
Kynar® and PVDF	-65°F/330°F (-54°C/166°C)*	5000 PSI (34,474 KP)	250%	1.8 Max
Material Property	Heat Aging	Dielectric Strength	Volume Resistivity	Water Absorption
Kynar® and PVDF	168 Hrs. @ 347°F (175°C)	10,000V	10 <sup>16</sup>	0.02%
Material Property	Solvent Resistance	Flammability	Fungus Resistance	
Kynar® and PVDF	No swelling, stickiness or weight change	Non-burning	Does not support fungus growth	

\*Note: Kynar® and PVDF material properties are identical, with the exception that Kynar® has been irradiated for thermal stability, and thus has a higher temperature rating of 166°C compared to 150°C for non-thermally-stabilized PVDF.

G-FLEX Siltem is Glenair's proprietary annular polymer-core convoluted tubing formulation, developed for harsh environment applications that require a lightweight, halogen-free material with exceptional flexibility and crush resistance

### Material Properties - G-FLEX Siltem

Material Property	Flexural Modulus	Flexural Strength	Tensile Strength	Elongation
	168,000 PSI	5590 PSI	5700 PSI	60%
	Melt Flow Rate	Dielectric Strength	Volume Resistivity	Water Absorption
38.0 G/10 min	422.9 V/mil	>1.E+16 Ohm-cm	0.58%	

### Series 72 Convoluted Tubing Product Selection Guide

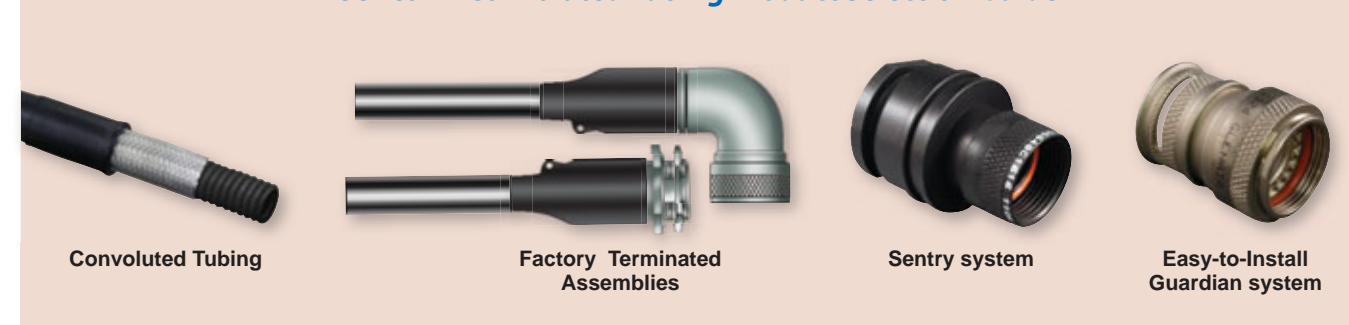



## Series 74 Helical Polymer-Core Conduit Systems



Seven standard tubing configurations,  
with and without braided shielding and jacketing

- **Lightweight, flexible helical polymer-core materials and easy to install fittings, transitions and adapters**
- **Choice of five materials: ETFE, FEP, PFA, PTFE, and PEEK**
- **Choice of turnkey, factory-terminated assemblies or user-installable configurations**
- **All popular part numbers in stock and ready for same-day shipment**

### Series 74 High-performance helical convoluted tubing, backshells, fittings and assemblies

Part Number  
120-100



#### Outstanding mechanical wire protection and lubricity for non-environmental and non-EMI/RFI applications

Helical plastic convoluted tubing, available in a choice of 5 materials. Choose standard black or clear color.

Part Number  
121-101



#### Adds EMI/RFI braided shielding for use in non-environmental applications

Helical plastic convoluted tubing, available in a choice of 5 materials, with a single braided shield for EMI/RFI protection.

Part Number  
121-102



#### Adds a second layer of high dB EMI/RFI shielding for use in non-environmental applications

Helical plastic convoluted tubing, available in a choice of 5 materials, with double braided shield for high frequency shielding applications.

Part Number  
121-100



#### A jacketed configuration with one EMI/RFI shield for use in environmental applications

Helical plastic convoluted tubing, available in a choice of 5 materials, with braided shielding for EMI/RFI protection and a ruggedized jacket for environmental protection.

Part Number  
121-103



#### Double-braided and jacketed configuration for environmental and high dB EMI/RFI shielding protection

Helical plastic convoluted tubing, available in a choice of 5 materials with double shielding and jacket for optimum EMI/RFI protection and environmental sealing.

Part Number  
123-100



#### For environmental applications without EMI shielding requirements

Helical convoluted tubing in choice of 5 materials with a ruggedized jacket for environmental protection.

Part Number  
121-195



#### Internal braid configuration for harsh chemical environment applications, with EMI/RFI shielding

Chemical- and UV-resistant plastic conduit tubing with internal braid for weight savings and harsh-environment EMI/RFI protection.

## Series 74 Helical Polymer-Core Conduit Systems



### Series 74 Convoluted Tubing Material Choices

E	ETFE (Tefzel®; Series 74 standard)	Highest tensile strength and lubricity. Combines mechanical toughness with outstanding chemical, dielectric and thermal properties, improved radiation resistance. This is our standard material for a reason: ETFE delivers the best performance and best value in high-performance polymer resins.
F	FEP	Economical with relatively high thermal stability, excellent dielectric properties. Unaffected by virtually all solvents and chemicals, good adhesion resistance.
P	PFA (Teflon®)	Outstanding lubricity and resistance to corrosives, -95°F to 500°F temperature rating. Melt-extruded for better cold flow and long-term sealing than PTFE; more economical.
T	PTFE (Teflon®)	Outstanding resistance to corrosives, -95°F to 500°F temperature rating. Somewhat better folding endurance than PFA. However, this paste-extruded Teflon® material is more difficult to process and so costs more than PFA with virtually equal performance.
K	PEEK	Low-smoke, zero-halogen with high strength and superior crush resistance. Lightest weight of all the tubing polymers, but also the highest material cost.

DuPont™ Teflon® and Tefzel® products are trademarks or registered trademarks of E.I. du Pont de Nemours and Company.

### Series 74 Convoluted Tubing Material Properties

Material Property	Perfluoroalkoxy (PFA)	Fluorinated Ethylene Propylene (FEP)	Ethylene Tetrafluoroethylene (ETFE)	Polytetrafluoroethylene (PTFE)	Polyether Ketone (PEEK)
Service Temperature	-95°F/500°F (-71°C/260°C)	-95°F/400°F (-71°C/204°C)	-65°F/310°F (-54°C/154°C)	-95°F/500°F (-71°C/260°C)	-76°F/392°F (-60°C/200°C)
Tensile Strength	3,000 PSI (20,684 KP)	2,500 PSI (17,237 KP)	5,000 PSI (34,474 KP)	2,500 PSI (17,237 KP)	7,000 PSI (48,300 KP)
Elongation	250%	200%	100%	175%	100%
Specific Gravity	2.15	2.15	1.70	2.15	1.26
Heat Aging	2000 Hrs. @ 525°F (274°C)	2000 Hrs. @ 430°F (221°C)	2000 Hrs. @ 350°F (177°C)	2000 Hrs. @ 525°F (274°C)	2,000 Hrs. @ 464°F (240°C)
Dielectric Strength	12,000V	12,000V	12,000V	12,000V	12,000V
Volume Resistivity	1018	1018	1016	1018	1016
Water Absorption	0.03%	0.01%	0.02%	0.01%	0.03%
Solvent Resistance	No swelling, stickiness or weight change				
Flammability	Non-burning				
Fungus Resistance	Does not support fungus growth				

### Series 74 Convoluted Tubing Product Selection Guide

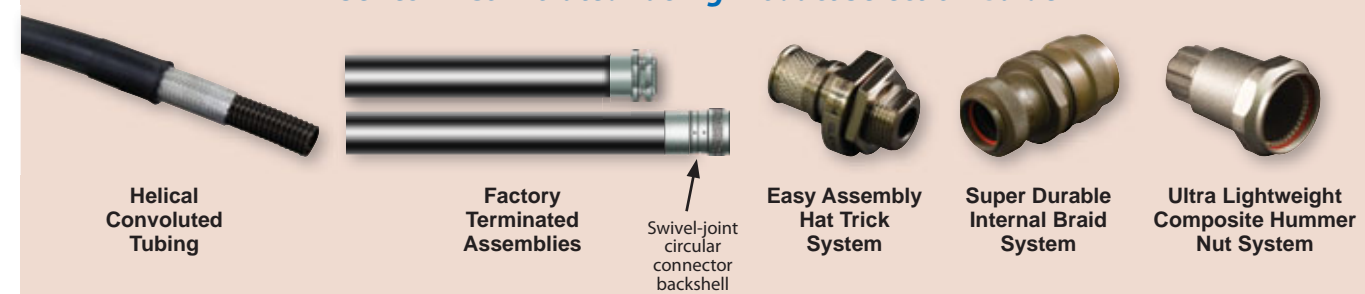



## Series 75 Metal-Core Conduit Systems



Copper-clad nickel iron conduit

- Hermetically sealed, flexible metal-core conduit for interconnect applications
- Choice of three materials: Brass, Stainless Steel, and Nickel Iron Alloy
- Turnkey, factory-terminated assemblies for landing gear and other rugged aerospace applications
- All materials deliver superior EMC performance as well as crush resistance and environmental sealing

### The ultimate in highly flexible, crush-proof EMI/RFI protection: Series 75 helical-wound metal-core conduit

<p><b>Part Number 750-190</b></p>	<p><b>Superior EMI protection and crush-proof strength for static applications</b></p> <p>Highly flexible crush-proof metal conduit, available in Nickel-Iron, Brass, or SST.</p>
<p><b>Part Number 750-191</b></p>	<p><b>Adds braided shielding for additional tensile strength applications</b></p> <p>Flexible metal-core conduit tubing with numerous braided shielding options, for additional tensile strength and effective grounding of electromagnetic interference.</p>
<p><b>Part Number 750-192</b></p>	<p><b>Adds a jacket for environmental protection</b></p> <p>Flexible metal-core conduit tubing with braided shielding plus a ruggedized jacket for environmental protection against contaminants and moisture.</p>
<p><b>Part Number 750-193</b></p>	<p><b>Adds a second braided shield for high dB EMI/RFI shielding</b></p> <p>Flexible metal-core conduit tubing with double braided shield for high frequency EMI/RFI shielding requirements.</p>
<p><b>Part Number 750-194</b></p>	<p><b>A jacketed, double-braided configuration for combined environmental and EMI/RFI applications with high dB shielding requirements</b></p> <p>Flexible metal-core conduit tubing with double braided shield and jacket for optimum EMI/RFI protection, strength and environmental sealing.</p>
<p><b>Part Number 750-195</b></p>	<p><b>Triple-braided conduit for predictable and reliable grounding of surface-borne/high frequency electromagnetic interference</b></p> <p>Flexible metal-core conduit tubing with triple braided shield for optimal tensile strength and enhanced high frequency EMI/RFI protection.</p>
<p><b>Part Number 750-196</b></p>	<p><b>Triple-braided and jacketed conduit for maximum EMI shielding in environmental applications</b></p> <p>Flexible metal-core conduit tubing with triple braided shield and jacket for enhanced high-frequency EMI/RFI protection, strength and environmental sealing.</p>



## Series 75 Metal-Core Conduit Systems

Conduit Material Choices, Material Properties, and Military Specifications			
Glenair Code	Material	Properties	Applicable Military Specifications
B	Brass, Per A-A-52440 Type I, Grade B	Optimal EMI shielding when combined with bronze overbraid. Generally specified with bronze overbraid and jacket.	<ul style="list-style-type: none"> <li>■ IAW A-A-52440 (Covering shielded, electrical, flexible, metal conduit for use as protection of wiring in military vehicles from mechanical injury and, when properly installed and grounded, to prevent radiation that may cause interference with radio and other electronic equipment.)</li> <li>■ MIL-C-13909 (Superseded by IAW-A-A-52440 above)</li> </ul>
C	Stainless Steel AISI 316	Specified for high-temperature, corrosion, and crush resistance. Nominal shielding value. Typically braided with stainless steel braid for additional pull strength and durability. Available with or without a jacket.	<ul style="list-style-type: none"> <li>■ MIL-PRF-24758 (Covering the performance requirements for weatherproof flexible conduit systems for use primarily in exposed areas on U.S. Navy ships, to shield against electromagnetic (EM) radiation from own-ship transmitters and emissions external to the ship, electromagnetic pulse (EMP) events, and to minimize corrosion while being field repairable to reduce maintenance.)</li> </ul>
N	Nickel Iron Alloy Type 4 ANSI/ASTM-A-753	80% Nickel, 20% Iron. Optimal low-frequency shielding material. Typically braided with stainless steel braid for additional pull strength and durability. Available with or without a jacket.	<ul style="list-style-type: none"> <li>■ MIL-DTL-28840 (Covering Connectors, Electrical, Circular, Threaded, High Shock, High Density, Shipboard, Metal Conduit, for EMI Shielding)</li> </ul>

EMI/RFI Braided Shielding and Non-Metallic (Fabric) Overbraids		
B	Bronze	Standard for for brass core conduit
T	Tin/Copper	150°C temperature rating, 125 lbs. tensile strength, 96 hr. salt spray corrosion resistance
C	Stainless Steel	Highest tensile strength (225 lbs.), highest temperature—1093°C+
N	Nickel/Copper	200°C temperature rated, 150 lbs. tensile strength, 500 hrs. salt spray corrosion resistance
S	SnCuFe	Tin plated iron/copper
L	ArmorLite™	Microfilament metal-clad ultra lightweight stainless steel braid
D	Dacron	Yarn with excellent abrasion resistance, good chemical resistance, non-conductive
M	Nomex	-55°C to 260°C temperature range - will not melt, excellent chemical resistance, non-conductive
E	AmberStrand® 100%	Expandable, flexible, high-strength conductive metal-clad composite thermoplastic
F	AmberStrand® 75%/25%	75% Expandable, flexible, high-strength conductive metal-clad composite thermoplastic combined with 25% nickel-plated 36AWG copper wire for additional strength

### Series 75 Metal-Core Helically-Wound Conduit Product Selection Guide

Metal-Core Helical-Wound Conduit
Turnkey Factory Terminated Assemblies
Low-Profile RP Plus System
Heavy-Duty Environmental Metal System
Heavy-Duty Environmental Conduit System

## MIL-PRF-24758 Navy Shipboard and Other Special Purpose Conduit Systems



- Qualified to MIL-PRF-24758A(SH)
- User-installable and factory terminated configurations
- Innovative stainless steel fittings with advanced environmental sealing, EMI shield termination and rotatable coupling nut
- Adapters for all shipboard interfaces—fully compatible with legacy MIL-C-24758 conduit system components

### Do it once, do it right with Glenair MIL-PRF-24758 and other special purpose wire protection conduit systems

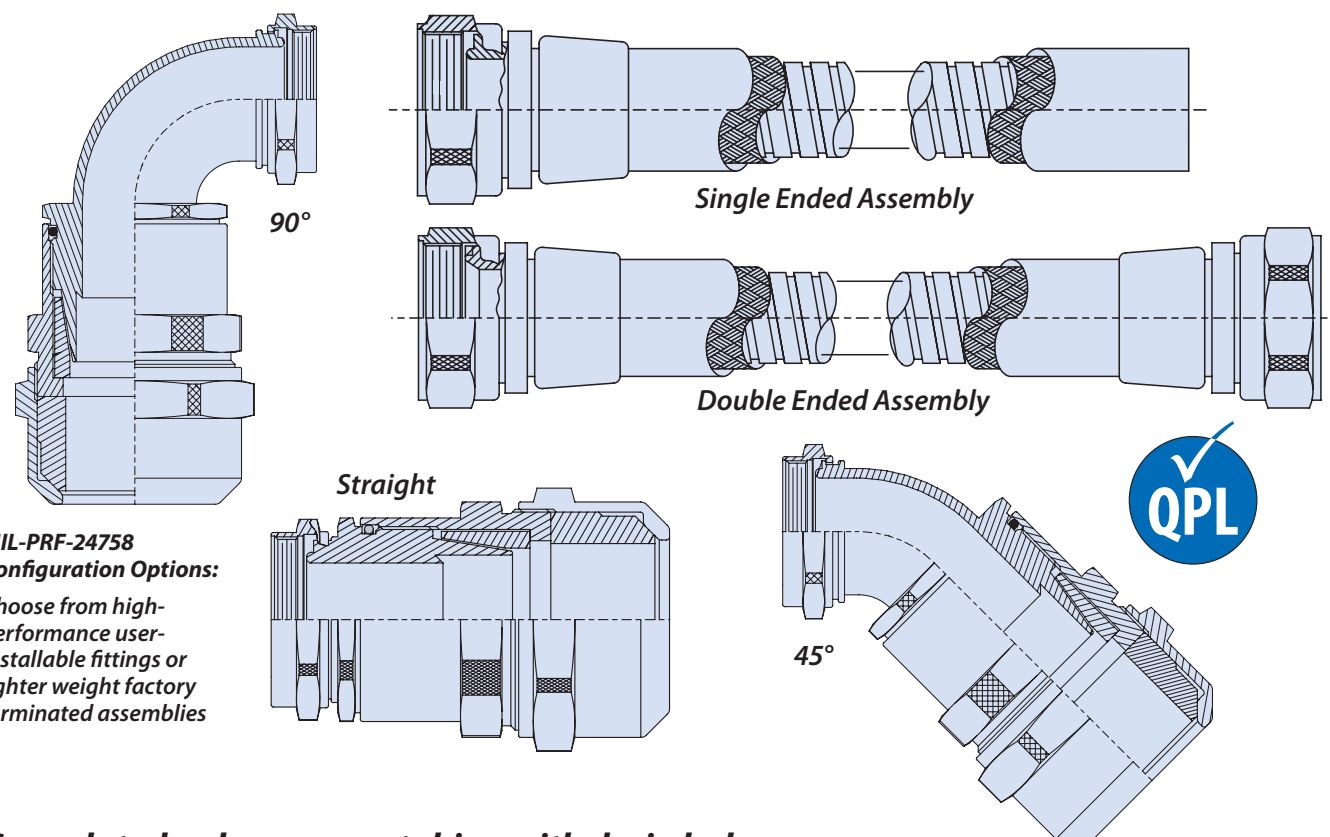

#### MIL-PRF-24758 Configuration Options:

Choose from high-performance user-installable fittings or lighter weight factory terminated assemblies

#### Convolute polymer-core tubing with drain holes



**Reference Part No.**  
(Consult factory for additional materials and configurations)

**120 - 143**

For aerospace applications where altitude changes can cause moisture condensation within conduit, Glenair produces convolute polymer-core tubing with drain holes. All major aircraft OEM hole patterns are on file, contact the factory for details on specific configurations.

## MIL-PRF-24758 Navy Shipboard and Other Special Purpose Conduit Systems

#### Wire-reinforced convolute polymer-core tubing



**Reference Part No.**  
(Consult factory for additional materials and configurations)

**127 - 009**

Glenair has developed a unique configuration where helical polymer-core tubing is reinforced with a stainless steel wire, adding at least 200 lbs. crush strength while maintaining the lightweight, chemical-resistant and environmental protection properties of Polymer-Core tubing.

#### Slit Polymer-Core tubing



**Reference Part No.**  
(Consult factory for additional materials and configurations)

**120 - 144**

Any of Glenair's regular bulk helical or annular polymer-core tubings can be provided slit, for on-site installation or addition of wires in open wire loom applications. Use the Wire Loom Tool for easy wire insertion: simply gather the wires into the tool, insert into the slit conduit, and run the tool through the tubing.



#### Oval Polymer-Core annular tubing

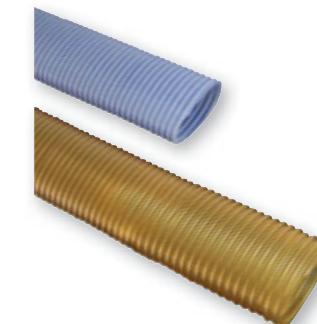

**Reference Part No.**  
(Consult factory for additional materials and configurations)

**120 - 140 - 40**

For specialized wire routing applications, Glenair can fabricate annular tubing with an oval shaped profile. In-house manufacturing allows us to design and fabricate non-standard shapes.

#### "No-Hal" halogen free flexible helical PEEK tubing assembly



**Reference Part No.**  
(Consult factory for additional materials and configurations)

**127 - 130**

The Glenair "No Hal" tubing assembly is designed for applications where RoHS compliance or other environmental standards mandate a halogen-free configuration. Halogen-free PEEK tubing (with optional stainless steel wire reinforcement for crush strength) is combined with Glenair halogen-free Duralectric™ jacketing material. Add an optional braided shield for EMI/RFI protection.

#### Dual-core tubing



In applications where helical convolute tubing needs to perform in harsh chemical environments, and weight savings is a concern, dual-core conduit is the answer. Glenair Series 74 Polymer-Core tubing materials are chemical- and UV resistant, and protecting the outside of tubing with a second layer of polymer tubing can save weight over standard jacketing. Consult the factory for Polymer-Core and braided shield material options.

QPL AND COMMERCIAL

# BACKSHELLS AND CONNECTOR ACCESSORIES FOR EVERY ENVIRONMENTAL, MECHANICAL, AND EMI REQUIREMENT



Glenair is one of the original military/aerospace manufacturers engaged in the design and production of high-performance backshells, dustcaps, shield termination devices and other connector accessories. In operation since 1956, Glenair has designed and produced more innovative connector accessory products than the rest of our industry combined. Glenair interconnect engineers are responsible for developing literally thousands of innovative connector accessories—from lightweight and corrosion-free composite thermoplastic strain reliefs to innovative fiber optic backshells. Today, the company is able to supply accessory solutions for every requirement, no matter how unique or challenging.

Circular Connector Backshells and Accessories



Rectangular Connector Backshells and Accessories



Composite Backshells and Accessories



EMI/RFI CostSaver Composite Junction Boxes







## Metal Circular and Rectangular Backshells and Accessories



- High-performance circular and rectangular connector accessories for every environmental, mechanical and electromagnetic shielding requirements
- QPL'd AS85049 backshells
- Tens of thousands of popular part numbers in inventory ready for same-day shipment
- Fast turnaround on non-standard and made-to-order accessories, typically only two to three weeks
- RoHS compliant plating options

**Innovation and availability: the Glenair connector accessory product line**



## Metal Circular and Rectangular Backshells and Accessories

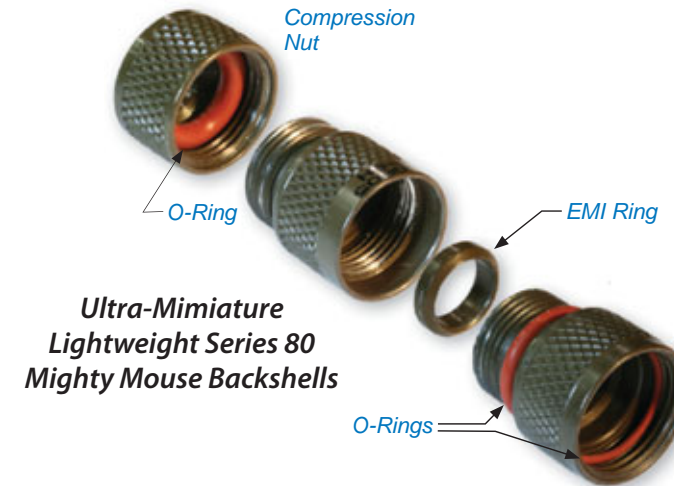

### EMI/RFI Backshell Designs

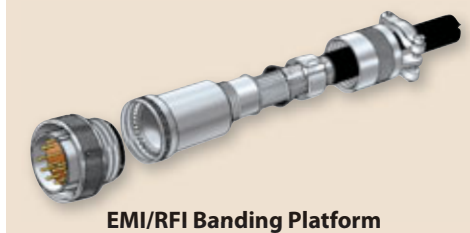
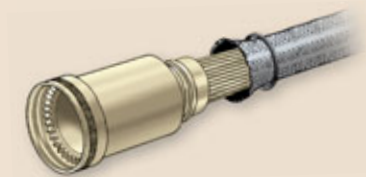
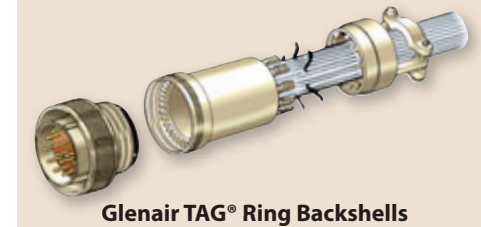

### Selected RoHS Compliant Plating Options



#### Nickel-PTFE

Cost	\$ \$ \$ \$ \$
Conductivity	++ ++ ++ ++ ++
Corrosion Resistance	∞ ∞ ∞ ∞ ∞
Operating Temperature	-65 to +175°C
Glenair Code	MT, XMT, ZMT



#### Electroless Nickel

Cost	\$ \$ \$ \$ \$
Conductivity	++ ++ ++ ++ ++
Corrosion Resistance	∞ ∞ ∞ ∞ ∞
Operating Temperature	-65 to +200°C
Glenair Code	M



#### Marine Bronze

Cost	\$ \$ \$ \$ \$
Conductivity	++ ++ ++ ++ ++
Corrosion Resistance	∞ ∞ ∞ ∞ ∞
Operating Temperature	-65 to +200°C
Glenair Code	AB



#### Stainless Steel

Cost	\$ \$ \$ \$ \$
Conductivity	++ ++ ++ ++ ++
Corrosion Resistance	∞ ∞ ∞ ∞ ∞
Operating Temperature	-65 to +200°C
Glenair Code	Z1, ZL, ZW



#### Black Zinc-Cobalt

Cost	\$ \$ \$ \$ \$
Conductivity	++ ++ ++ ++ ++
Corrosion Resistance	∞ ∞ ∞ ∞ ∞
Operating Temperature	-65 to +175°C
Glenair Code	UCR, F7



#### Black Anodize

Cost	\$ \$ \$ \$ \$
Conductivity	++ ++ ++ ++ ++
Corrosion Resistance	∞ ∞ ∞ ∞ ∞
Operating Temperature	-65 to +175°C
Glenair Code	C



## Composite Circular and Rectangular Backshells and Accessories



- High temperature, high strength engineering composite thermoplastics for maximum strength and durability
- Total immunity to galvanic corrosion
- Up to 70% weight reduction compared to standard metal connectors and accessories
- Hundreds of innovative, tooled designs
- All popular part numbers in stock and ready for immediate, same-day shipment



**Corrosion resistance, weight reduction, durability and design innovation**

### 1000 Hour Grey™ Ni-PTFE Nickel Fluorocarbon Polymer Plating



The MIL-DTL-38999 Rev L detail specification lists Nickel Fluorocarbon Polymer as a qualified Cadmium free plating alternative. This highly conductive, RoHS compliant plating formula is now available on composite interconnect products from Glenair and offers the following benefits in harsh-environment applications:

- 2000+ hour salt spray
- Cadmium free
- Outstanding mating lubricity
- Hexavalent Chromium free
- 500+ mating cycles
- Non-Magnetic

### Ultra-Lightweight Composite Thermoplastic Shield Termination

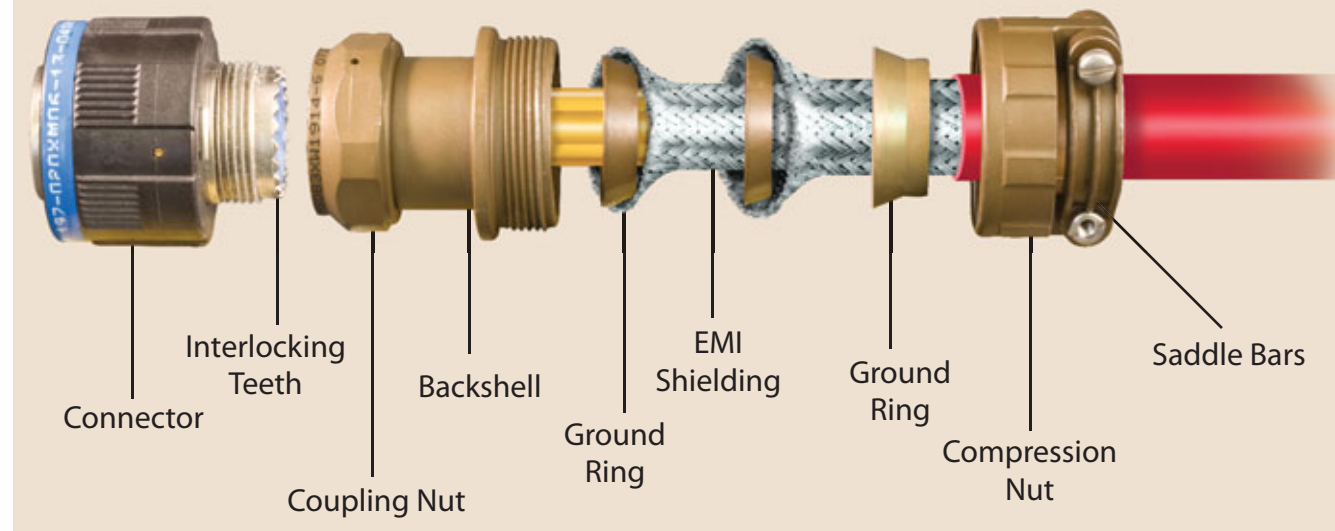

## Composite Circular and Rectangular Backshells and Accessories



### Plated Composite

Cost	\$	\$	\$	\$	\$
Conductivity	+	+	+	+	+
Corrosion Resistance	8	8	8	8	8
Operating Temperature	-65 to +200°C				
Glenair Code	XM, XW, XMT				

### Unplated Composite

Cost	\$	\$	\$	\$	\$
Conductivity	+	+	+	+	+
Corrosion Resistance	8	8	8	8	8
Operating Temperature	-65 to +175				
Glenair Code	XB, XO				

### Standard Finishes

SYM	MATERIAL	FINISH
XO	Composite Thermoplastic	No Plating, Natural
XB		No Plating, Black
XZN		Conductive, Zinc Nickel, Black
XM		Conductive, Electroless Nickel
XMT		Conductive, Ni-PTFE 1000 Hour Grey™
XW		Conductive, Cadmium O.D. Over Electroless Nickel

### Composite Thermoplastic Vs. Common Metal Materials

Material	Specific Gravity	Density (lbs. Inch <sup>3</sup> )	Salt Spray
Composite	1.27 - 1.51	.055	2000+ Hrs
Aluminum	2.55 - 2.80	.098	48-1000 Hrs
Titanium	4.51 - 4.62	.162	500-1000 Hrs
Stainless Steel	7.70 - 7.73	.284	500-1000 Hrs
Brass	8.40 - 8.70	.305	500-1000 Hrs



Glenair composite interconnect components are principally manufactured from 30% glass fiber polyetherimide (PEI), an amorphous thermoplastic with outstanding heat and chemical resistance and high strength. At room temperature the 30% glass filled PEI exhibits strength far beyond that of most engineering thermoplastics, with a tensile strength yield of over 15,000 psi. The PEI material meets the most stringent outgassing and flammability requirements.

### Composite Design Innovation Reduces Cable Harness Assembly Time





## EMI/RFI CostSaver Composite Junction Boxes



- Over a dozen different tooled sizes and shapes.
- Made-to-order configurations available—just ask.
- Extremely durable, corrosion-free, high temperature engineering composite thermoplastic
- Tested and qualified to U.S. Navy, UK MOD and hundreds of commercial aircraft and marine applications

Glenair EMI/RFI CostSaver Composite Junction Box application—protecting and storing fiber optic media service loops

### Install it and forget it: Glenair corrosion-free EMI/RFI shielded composite junction boxes

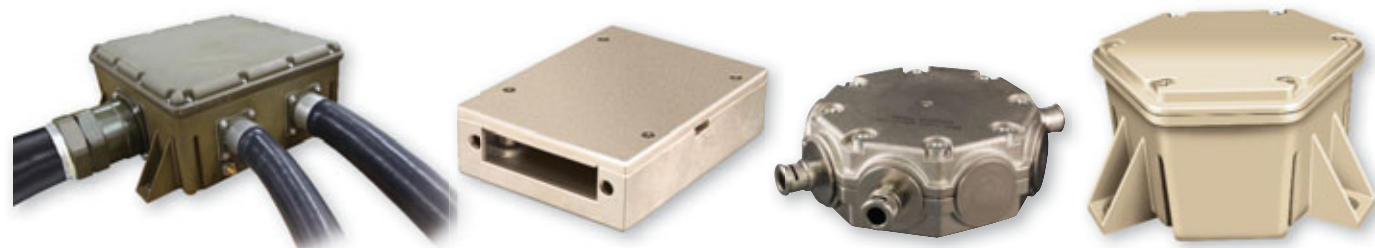

#### Ultra-Lightweight and Corrosion-Free

- Series 316 stainless steel hardware provides long-term durability
- IP67 rated seals and gaskets protect equipment from moisture and dust
- Unlimited corrosion resistance compared to metal junction boxes reduces repair and maintenance costs.
- Low harmonic resonance and inherent attenuating properties reduce loosening and decoupling of feed-through fittings and accessories.
- Glass reinforced composite thermoplastic material is strong and durable and yet extremely lightweight.



## EMI/RFI CostSaver Composite Junction Boxes

#### Glenair Composite Box Product Specifications

Description/Test Report	Requirement	Procedure
<b>Plating Adhesion</b> <i>Glenair #9-44-18/TN94-159</i>	Should not exhibit any blistering, peeling or other separation of the units plating.	Tested IAW MIL-DTL-38999.
<b>Vibration</b> <i>NTS #973-7369-2</i>	Should not exhibit loosening of component parts or evidence of damage.	Tested IAW MIL-STD-167 Type 1 for box units and MIL-STD-1344, Method 2004 Condition II for fittings and accessories.
<b>Shock</b> <i>NTS #973-7369-2</i>	There shall be no loosening of parts or evidence of damage.	IAW MIL-STD-901D, Lightweight, Grade C.
<b>Shock</b> <i>MOD #BR8470 Grade C and F</i>	There shall be no loosening of parts or evidence of damage.	Tested IAW MOD BR 8470 Grade C and F.
<b>Salt Spray</b> <i>Glenair #9-44-18/TN94-159</i>	Should exhibit no exposure of underplate or base material.	Tested IAW MIL-STD-1344, Method 1001.
<b>Dust</b> <i>NTS #973-7369-1</i>	Should conform to required torque limits and functional requirement within 25%.	Tested IAW MIL-STD-202.
<b>UV Light Resistance</b> <i>GE RDM88050255-6042</i>	No degradation of the mechanical properties defined in the specification after testing.	Tested IAW ASTM D2565.
<b>Impact</b> <i>MIL-STD-1344, Method 2015</i>	No evidence of breaking or cracking of components or other damage that could affect the product performance.	Tested IAW MIL-STD-1344, Method 2015.
<b>External Bending Moment</b> <i>Glenair #9-44-18/TN94-159</i>	No evidence of damage detrimental to normal operation when subjected to 3X magnification.	Tested IAW MIL-STD-1344.
<b>Temperature Cycling</b> <i>NTS #575-9249</i>	No cracking, peeling or separation of plating or other functional damage.	Tested IAW MIL-STD-1344, Method 1003 at -65°C to 200°C.
<b>Hydrolytic Stability</b> <i>NTS #878-536</i>	No evidence of increased weight greater than 1% and no evidence of cracking, breaking or loosening of component parts.	Tested IAW ASTM D570-81.
<b>Ice Resistance</b> <i>Glenair #9-44-18/TN94-159</i>	The test item must conform to required torque limits and functional requirements within 25%.	Tested IAW Glenair #9-44-18/TN94-159.
<b>Flammability</b> <i>MIL-STD-1344, Method 1012, Smoke Index, NES 711 Issue 2, NES 713 Issue 3 and ISO 4589</i>	The item flame and after flow extinguishing time shall not exceed the defined limits.	Tested IAW Table II of of MIL-STD-1344, Method 1012, Smoke Index, NES 711 Issue 2, NES 713 Issue 3. Burning behavior by Oxygen Index, ISO 4589.
<b>Water Tightness</b> <i>EA #0C13513-039514</i>	Water tightness and internal pressurization is maintained.	Tested IAW EA #0C13513-039514.
<b>Outgassing</b> <i>JPL #081892</i>	Maximum allowable weight loss is 10%.	Tested IAW ASTM E 595.
<b>Electromagnetic Shielding</b> <i>TRW/ABQ-55C-1186-0</i>	Should demonstrate shielding effectiveness and transfer impedance conforming to military industry standards and specific customer requirements.	Tested IAW TRW/ABQ-55C-1186-0.

**HEAVY-DUTY**

# INTERCONNECT ASSEMBLY TOOLS

THE RIGHT TOOL FOR EVERY INTERCONNECT ASSEMBLY REQUIREMENT



Glenair offers its connector and connector accessory customers every convenience in the provision of contact termination, shield termination, and backshell-to-connector assembly tooling. We are also proud to offer branded solutions from other well-known tool manufacturers such as Daniels (DMC) crimp tools. From pneumatic Earth-Bond tooling for the rail industry, to fiber optic termination and test equipment, Glenair is your most knowledgeable and reliable source for special-purpose interconnect assembly tooling.

Backshell-to-Connector Assembly Tools



BandMaster™ ATS EMI/RFI Shield Termination System





## BandMaster™ ATS EMI/RFI Shield Termination Equipment

BandMaster™ Hand Banding Tool  
600-058 Standard Band  
600-061 Micro Band



Now available with  
built-in calibration counter

- Fast, cost-effective cable shielding termination
- Precision hand-held tool and bands deliver reliable, repeatable performance
- Single piece stainless steel bands in various sizes and lengths
- Clamp both small and large diameters easily and reliably
- Pneumatic banding tool for high-speed mass production
- Qualified for both military and commercial aviation

**The BandMaster™ ATS provides quick, easy, cost-effective and highly reliable termination of braided metallic shielding or fabric braid to connectors and backshells.**

The unique low profile and smooth inside diameter of the one-piece type 304 austenitic stainless steel clamping band virtually eliminates RFI/EMI/EMP leakage paths. The lock maintains constant tension under extreme environmental conditions. *BandMaster™ ATS* bands have passed severe shock, vibration and thermal cycle testing with negligible deterioration of shell conductivity.

Standard Band 600-052  
Precoiled Standard Band 600-052-1

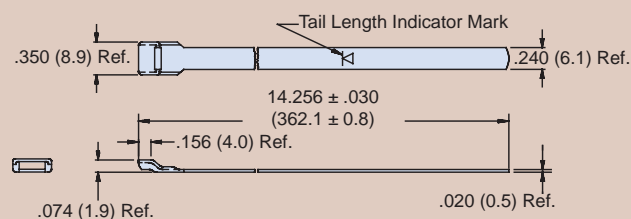

Micro-Band 600-057  
Precoiled Micro-Band 600-057-1

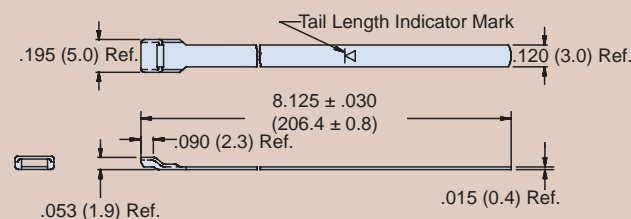

Extended-Length Standard Band 600-090  
Precoiled Extended-Length Standard Band 600-090-1

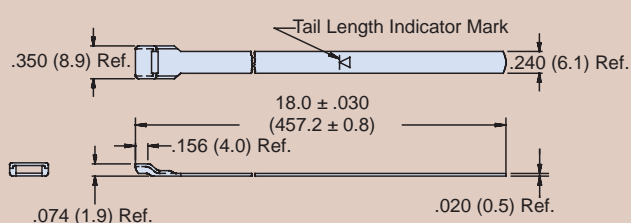

Extended Length Micro-Band 600-083  
Precoiled Micro-Band 600-083-1

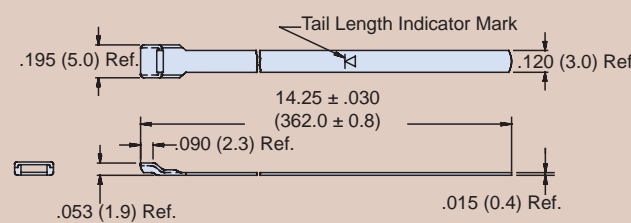

## BandMaster™ ATS EMI/RFI Shield Termination Equipment



### BandMaster™ Advanced Termination System

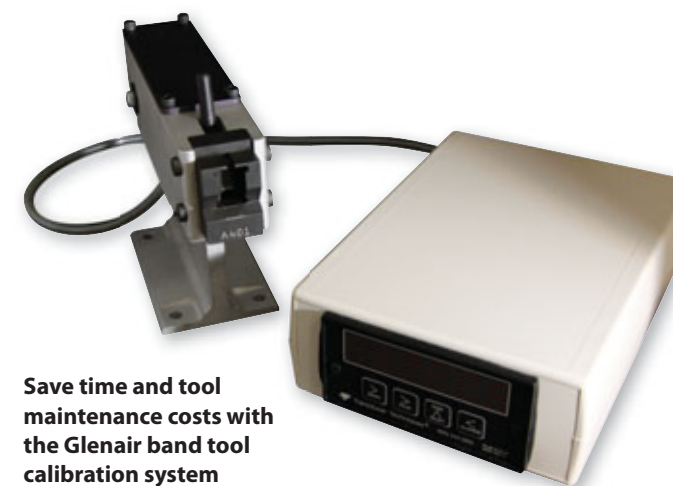

Save time and tool  
maintenance costs with  
the Glenair band tool  
calibration system

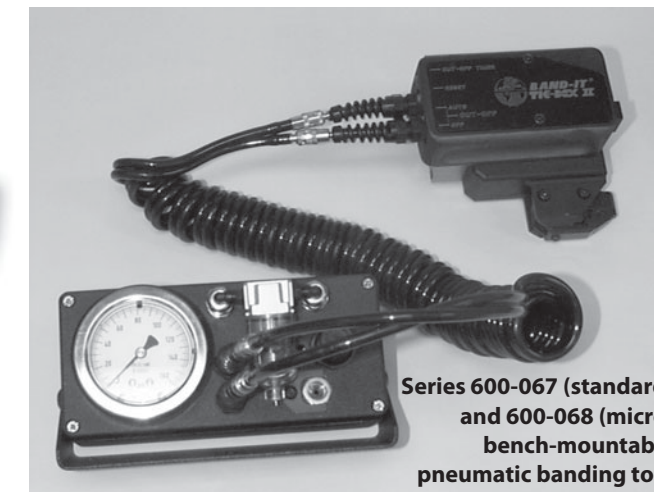

Series 600-067 (standard)  
and 600-068 (micro)  
bench-mountable  
pneumatic banding tool



#### Step One: Cable Prep

Lay individual shields over the band platform. Pull overall braid shield over the band platform so that all braid strands will be captured by the band.



#### Step Two: Install Band

Wrap the band through the buckle twice. Insert the free end into the banding tool in the direction shown on the tool. Squeeze the short grey handle to insert the band. Slide the band onto the cable. Close the black handle repeatedly until the handle no longer opens. Close the long grey handle until the tool cuts the band. Remove the excess band from the tool by closing the small grey handle.

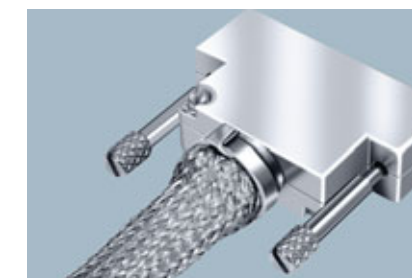

#### Step Three: Trim Braid

It's a snap! Just trim the excess braid and you're done.



Series 687-749  
banding split support  
rings for use with  
shield sock band  
termination



#### How To Order Bands

Band Type	Width		Length		Part Number		Use With Tool	Accommodates Dia.	
	In.	mm.	In.	mm.	Uncoiled	Coiled		In.	mm.
Micro Band, Standard Length	.120	3.05	8.125	206.38	600-057	600-057-1	600-061	.88	22.35
Micro Band, Extended Length	.120	3.05	14.25	361.95	600-083	600-083-1	600-061	1.88	47.75
Standard Band, Standard Length	.240	6.10	14.256	362.10	600-052	600-052-1	600-058	1.80	45.72
Standard Band, Extended Length	.240	6.10	18.00	457.20	600-090	600-090-1	600-058	2.50	63.50



## Backshell-to-Connector Assembly Tools



- Backshell-to-connector holding tools for all cylindrical connectors and accessories in current use
- Special composite thermoplastic coupling nut holding tools
- Discrete tools and complete sets available
- Popular Glenair strap wrenches
- Hand-held and bench-mountable digital torque wrenches
- Cutting shears and other special-purpose cable assembly tools

**Glenair offers a complete family of backshell assembly tools for most Mil-Standard circular connectors, as well as connector wrenches, strap wrenches, and universal connector holding tools**

### Torque Wrenches and Bench Stands



**Hand-Held Torque Wrench  
600-076 High Torque  
600-004 Standard Torque**



**Digital Torque Wrench 600-161**

**Bench Stand for  
the 600-076 and  
600-004 Torque  
Hand-Held  
Wrenches**

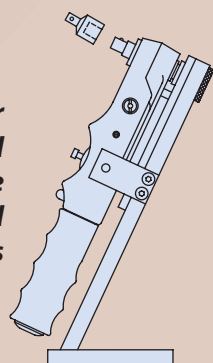

**Bench Stand  
600-162  
For Digital  
Torque Wrench  
600-161**



**Vertical and  
Horizontal  
Mounting  
Options**

## Backshell-to-Connector Assembly Tools



### Glenair Offers a Complete Family of Backshell Assembly Tools



**Glenair TG70  
Strap Wrench  
with Square Drive  
for Torque Wrench**



**TG69 Soft Jaw Pliers**

### Backshell Coupling Nut Wrenches



**Coupling Nut Wrench for  
Composite Backshells**

### Connector Holding Wrenches for Most Military Standard Circular Connectors



- TG47** • MIL-DTL-22992
- TG48** • MIL-DTL-38999 Series II
- TG52** • MIL-DTL-81511 Series II and IV
- TG60** • MIL-DTL-27599 and MIL-DTL-38999 Series I
- TG61** • MIL-DTL-81511 Series I and II
- TG83** • (LN29729) for SJT Connectors
- TG90** • MIL-DTL-38999 Series III



**Spanner Tool for  
Tightening Series 80  
Jam Nuts**

### Backshell Assembly and Repair Tool Kits

The **TG80 Tool Kit** is designed for field use with circular electrical connectors. Tool Kits conforming to the requirements of **MIL-T-83507** are also available

### Plug and Receptacle Holding Tools for Backshell-to-Connector Assembly



**Plug  
Holder**

**Receptacle  
Holder**

**MISSION CRITICAL**

# HIGH RELIABILITY CABLE ASSEMBLIES

**CUSTOMER BESPOKE CABLE HARNESSSES AND  
ASSEMBLIES FOR MIL/AERO APPLICATIONS**



**Harsh  
Environment  
Overmolded  
Multi-Branch  
Assemblies**

**Inside-the-Box Fiber Optic/  
Electric Pigtail Assemblies**



**Harsh Environment Fiber Optic/  
Electrical Assemblies**



**Multi-Branch Assemblies  
with Protective Fabric  
Braiding**



**Miniature Micro and  
Nano Open Wire  
Bundle Assemblies**

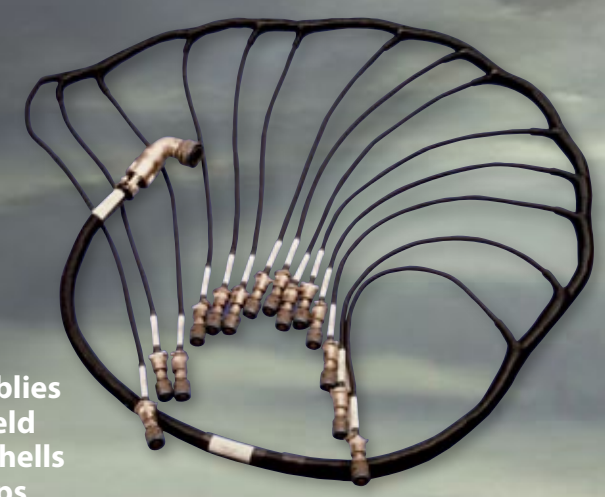

**Repairable Assemblies  
with Glenair Shield  
Termination Backshells  
and Cable Clamps**

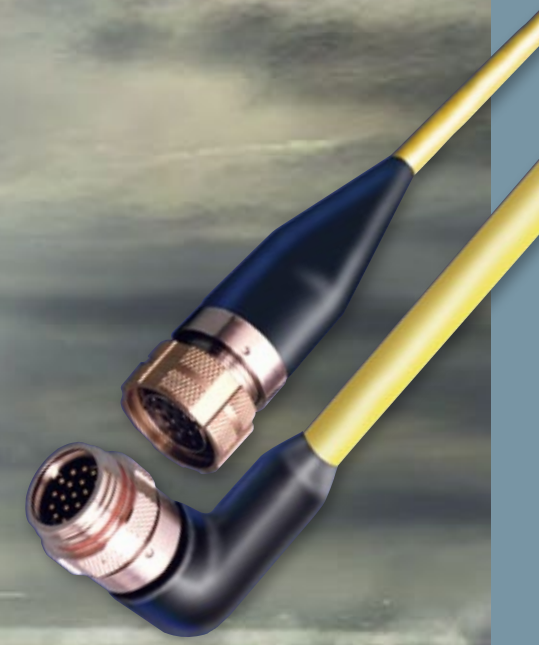

**Harsh  
Environment  
Overmolded  
Cables**

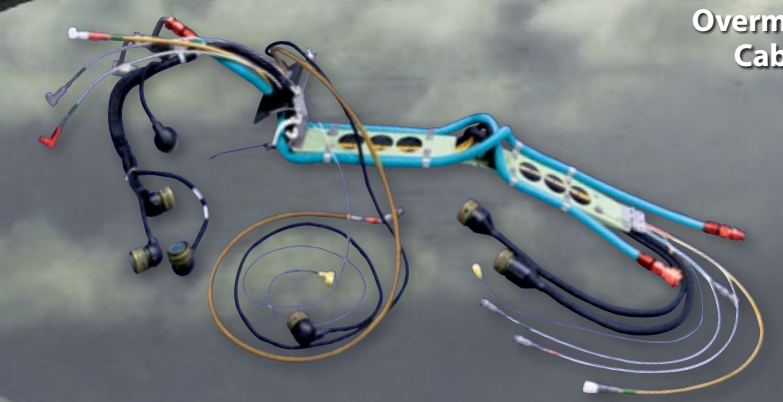

**Complex  
Interconnect  
Assemblies with  
Industry-Standard  
Connectors and  
Fittings**



**Wired, Terminated  
and Tested Conduit  
Assemblies**

**G**lenair has been the go-to cable house for high-performance interconnect cable assemblies for more than 50 years. We specialize in delivering terminated, tested cable harnesses and assemblies with 100% reliability and quality control. We offer complete, turnkey cable assembly services from design engineering to fabrication and test, and are qualified to all military and commercial aerospace standards.



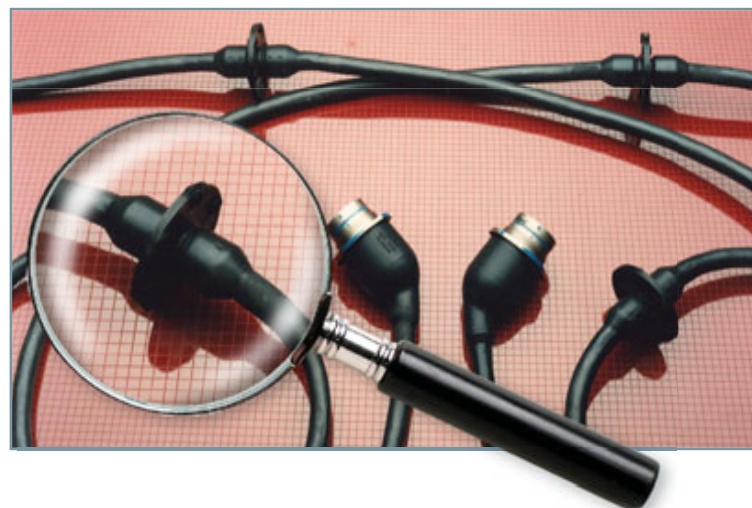

### Advantages of Overmolding

- Waterproof sealing
- Robust mechanical protection
- Protection of terminations
- Ideally suited for chemical and fuel cell applications
- No induced cold flow stress
- Electrical isolation and insulation
- Reduced wear damage
- Flexible routing/cable entry

**Terminated, overmolded, tested, and ready for use. Glenair cable harnesses and assemblies are recognized industry-wide for quality and reliability**

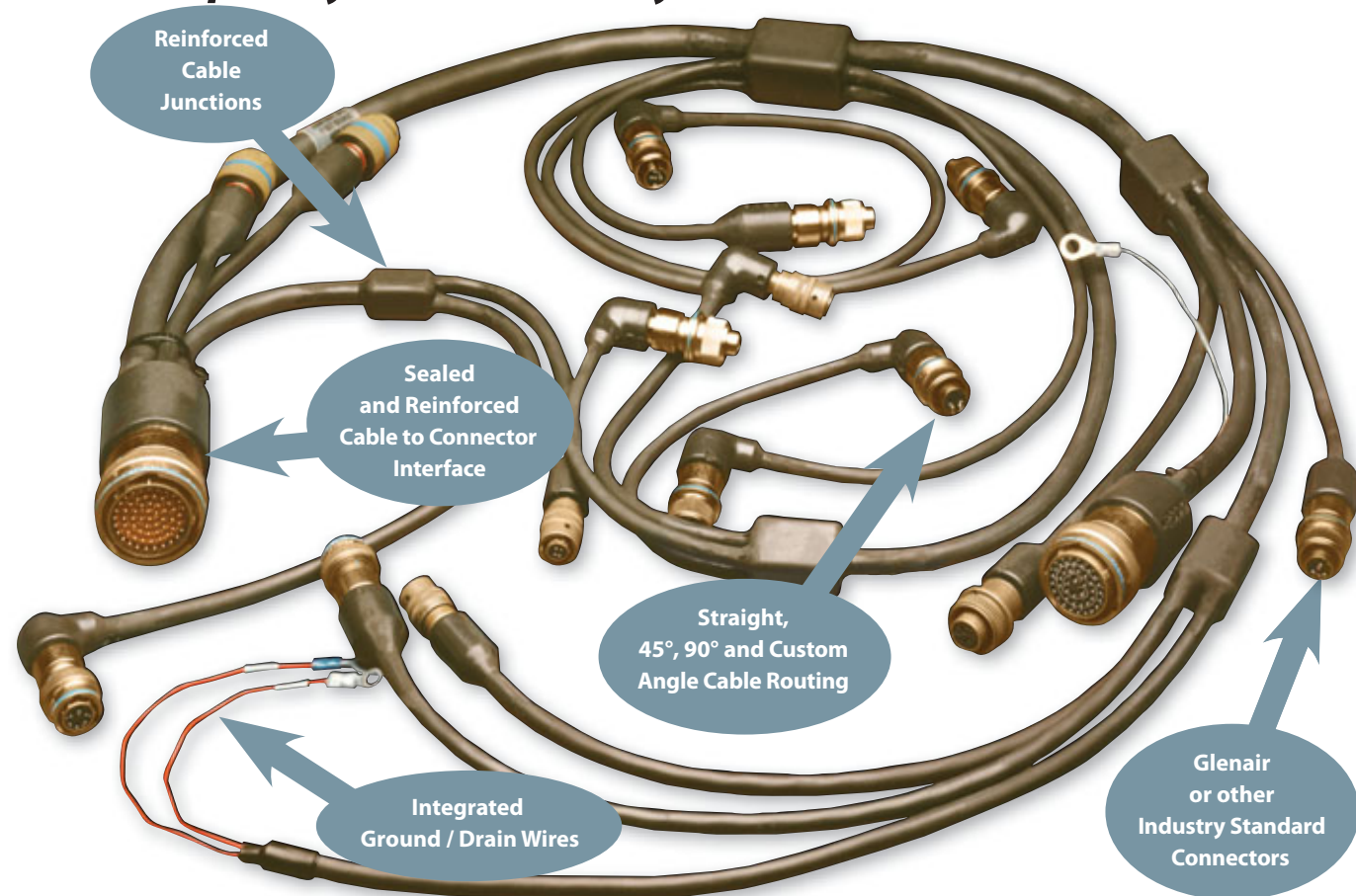

**Point-to-point jumper cables and cordsets for high-speed and high-reliability applications—easy to order and shipped ready for immediate use**



USB Type A Plug  
to Mighty Mouse  
Connector ASAP  
Cordset



ASAP  
Micro Wire Harnesses

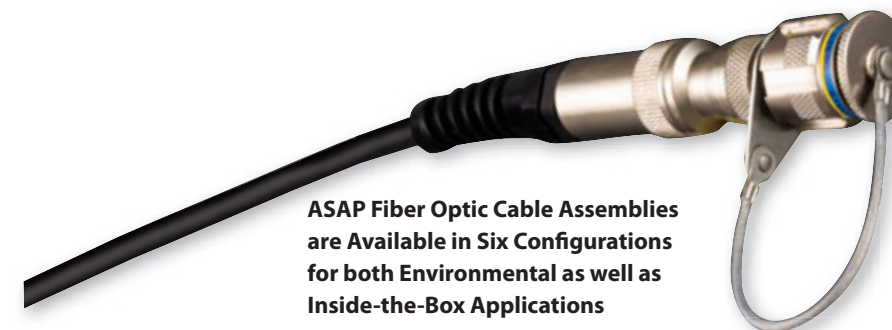

ASAP Fiber Optic Cable Assemblies  
are Available in Six Configurations  
for both Environmental as well as  
Inside-the-Box Applications



ASAP  
High Speed Cables



Cat 5 RJ-45 to Mighty Mouse Connector  
ASAP Cordset

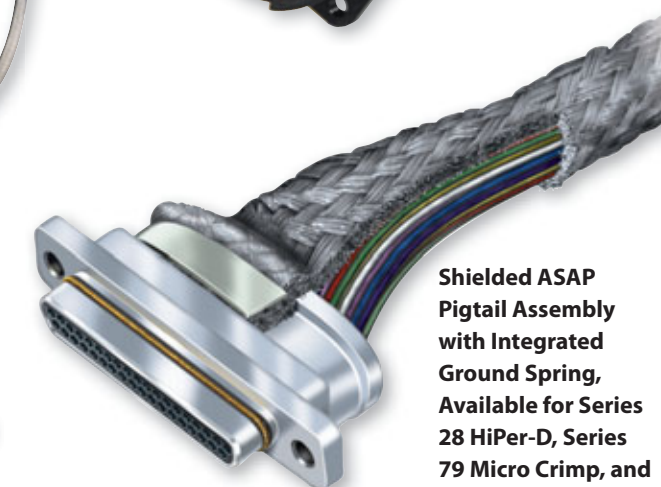

Shielded ASAP  
Pigtail Assembly  
with Integrated  
Ground Spring,  
Available for Series  
28 HiPer-D, Series  
79 Micro Crimp, and  
83513 type Micro-D

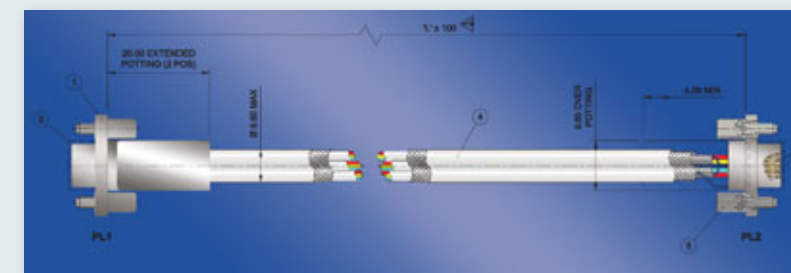

Glenair ASAP SpaceWire cable assembly. Purpose-designed and available with accelerated lead times, this space-grade high-speed jumper cable meets the stringent requirements of the European Space Components Coordination Detail specification 3401/701





- Glenair can design, build, terminate—and even pre-wire—turnkey conduit wire routing solutions.
- Certified factory assemblers and calibrated tooling create better-performing systems.
- Simple point-to-point or complex multi-branch.

**Reduce package size, weight, and labor with turnkey factory assemblies**

Part Number  
744-204

**Series 74 Helical Polymer-Core Convuluted Tubing Assembly example:**  
Circular Connector Backshell to 45° Series 79 Micro-Crimp Connector Backshell



Part Number  
754-007

**Series 75 Flexible Metal-Core Conduit Assembly example:**  
Band-In-A-Can Connector Backshell to Band-In-A-Can Connector Backshell



The Series 72 and 74 Polymer-Core Convuluted Tubing Systems offer the industry's broadest selection of high-performance materials—all designed to optimize flex cycles, temperature resistance, and weight reduction.

Internally-braided tubing systems provide a lightweight and chemically-resistant package without the use of conventional outer jacketing.

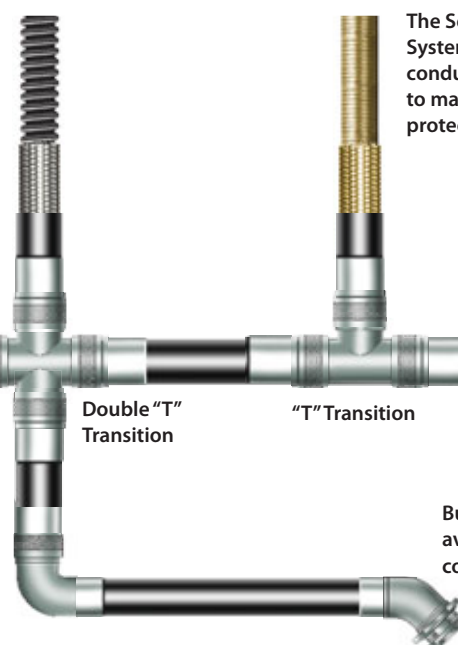

Double "T" Transition

"T" Transition

Detachable 90° Elbow Adapter for easy wire maintenance

Bulkhead Feed-Thru Fittings are available in Straight, 45°, and 90° configurations.

The Series 75 Metal-Core Conduit System offers a wide range of flexible conduit core materials, all designed to maximize crush resistance and EMI protection.

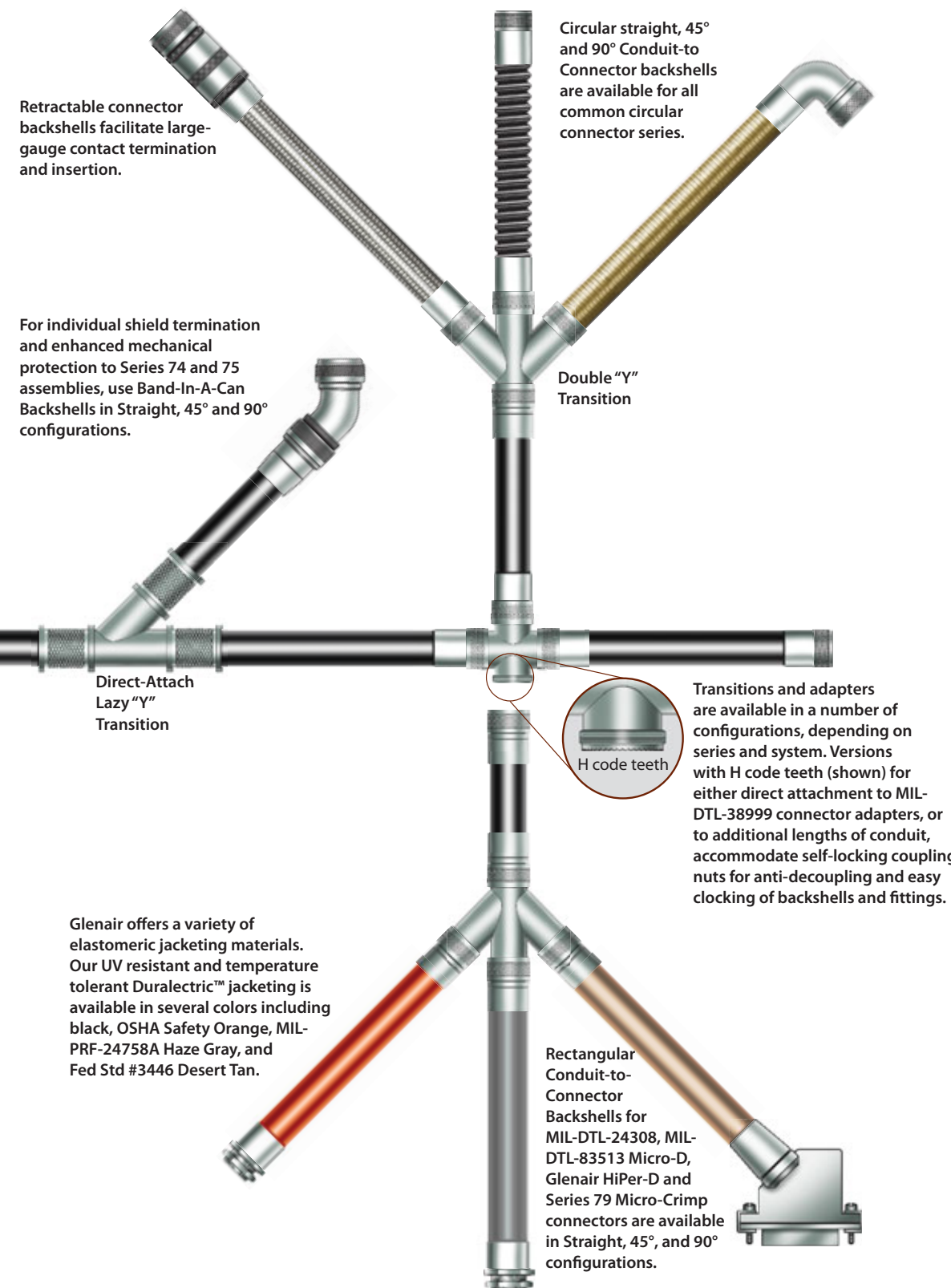

Retractable connector backshells facilitate large-gauge contact termination and insertion.

Circular straight, 45° and 90° Conduit-to-Connector backshells are available for all common circular connector series.

For individual shield termination and enhanced mechanical protection to Series 74 and 75 assemblies, use Band-In-A-Can Backshells in Straight, 45° and 90° configurations.

Double "Y" Transition

Direct-Attach Lazy "Y" Transition

H code teeth

Transitions and adapters are available in a number of configurations, depending on series and system. Versions with H code teeth (shown) for either direct attachment to MIL-DTL-38999 connector adapters, or to additional lengths of conduit, accommodate self-locking coupling nuts for anti-decoupling and easy locking of backshells and fittings.

Glenair offers a variety of elastomeric jacketing materials. Our UV resistant and temperature tolerant Duraelectric™ jacketing is available in several colors including black, OSHA Safety Orange, MIL-PRF-24758A Haze Gray, and Fed Std #3446 Desert Tan.

Rectangular Conduit-to-Connector Backshells for MIL-DTL-24308, MIL-DTL-83513 Micro-D, Glenair HiPer-D and Series 79 Micro-Crimp connectors are available in Straight, 45°, and 90° configurations.

# Why Choose **GLENAIR?**



Plenty of Raw Materials!



Outstanding  
Customer Service!



High-Production Injection  
Molding Equipment

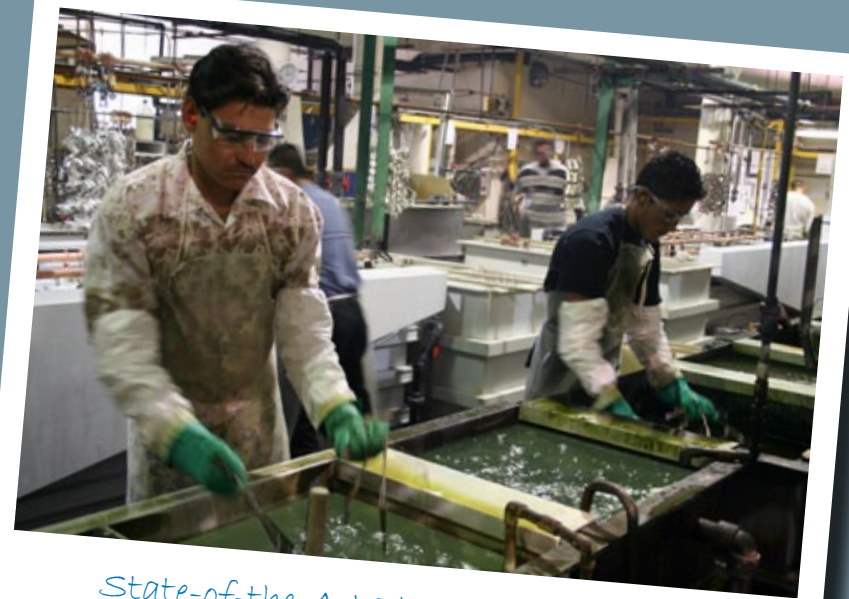

State-of-the-Art Plating Capabilities



Abundant Machining Capacity!



In-House Assembly!



The Industry's Most Experienced  
EMI/RFI Braided Shielding Specialists



Huge "Same-Day" Inventory!



One of North America's Largest CNC Milling  
and Machining Installations



Clean Rooms for Filter Array and Printed  
Circuit Board Assembly

## Out of this world

I'm pleased to offer our QwikConnect subscribers this comprehensive overview of Glenair's connector, wire protection and cable harness capabilities. I have a few comments I'd like to share with the Glenair family about this publication—particularly how well the products in this book reflect our dedication to new product development, innovation and our commitment to listening to our customers.

**New Product Development:** Glenair has been in the interconnect industry since 1956, manufacturing our first product, a simple cable clamp on Air Way in Glendale, California. While we are still located on Air Way, plenty has changed over the last 50 plus years. We now manufacture thousands of industry-standard and special purpose connector designs, backshells, wire protection and management products, cable harnesses, lightweight EMI/RFI shielding solutions and more. We didn't get to where we are overnight, but a current snap-shot of Glenair shows just how far we have come, and just how dedicated we are to making new and ongoing product development a mainstay of our business.

**Innovation:** Even a cursory look at this publication reveals just how innovative our product people and engineers have become. From our industry-leading Series 80 Mighty Mouse connector to our brand new and ultra-miniature SuperFly™ cordsets, Glenair has become the go-to market leader for innovation in interconnect systems. While many of our industry peers are seemingly content to rely on existing designs and their long-term print position in high-reliability systems, Glenair has taken steps to gear our outfit with a focus on innovation—tackling the toughest problems around—from size and weight reduction to better solutions for high-speed data transmission.

**Listening to Our Customers:** For me, this is the most important take-away from this impressive guide to Glenair's complete capabilities in interconnect systems. Literally all our business development work—from the expansion of our engineering and support capabilities to the growth of our factory space and manufacturing resources—have been undertaken with one goal in mind: Responding with as much urgency as we can muster to the needs of our customers. Believe me, we understand there is no better way to address those needs than to conduct every customer conversation with our ears wide open.

The title of this new overview of our work is "*Out of This World Interconnect Solutions.*" And while that may sound a bit hyperbolic, I'm convinced that Glenair products and our unmatched commitment to customer service puts us in a class all our own. As always, I welcome your comments and observations on just how well we are doing to live up to the lofty "out of this world" standards we have set for ourselves.

*Chris Toomey*

## Publisher

Christopher J. Toomey

## Executive Editor

Marcus Kaufman

## Managing Editor

Carl Foote

## Editor

Mike Borgsdorf

## Art Director

Charles W. Belser

## Technical Consultant

Jim Donaldson

## Issue Contributors

Lisa Amling  
Deniz Armani  
Alex Boone  
Greg Cameron  
Ken Cerniak  
Mike Connal  
Garrett Croft  
Yvette Curry  
Brendan Dempsey  
Monish Doshi  
Ty Geverink  
Ralph Hays  
Guido Hunziker  
Tom Lemenager  
Sheila Melcher  
Donna Miller  
Greg Noll  
Jim Plessas  
George Ramirez  
Tim Shanry  
Dave Tonkiss  
Fred VanWyk

## Distribution

Terry White

QwikConnect is published quarterly by Glenair, Inc. and printed in the U.S.A. All rights reserved. ©2012 Glenair, Inc.

## GLENAIR, INC.

1211 AIR WAY  
GLENDALE, CA 91201-2497  
TEL: 818-247-6000  
FAX: 818-500-9912  
E-MAIL: sales@glenair.com  
www.glenair.com





*Out of This World*  
**INTERCONNECT  
SOLUTIONS**

**Glenair, Inc.**

1211 Air Way • Glendale, California • 91201-2497  
Telephone: 818-247-6000 • Fax: 818-500-9912 • sales@glenair.com  
[www.glenair.com](http://www.glenair.com)

**Glenair Power  
Products Group**

860 N. Main Street Extension  
Wallingford, CT  
06492

Telephone:  
203-741-1115  
Facsimile:  
203-741-0053  
sales@glenair.com

**Glenair UK Ltd**

40 Lower Oakham Way  
Oakham Business Park  
P.O. Box 37, Mansfield  
Notts, NG18 5BY England

Telephone:  
+44-1623-638100  
Facsimile:  
+44-1623-638111  
sales@glenair.co.uk

**Glenair Microway Systems**

7000 North Lawndale Avenue  
Lincolnwood, IL  
60712

Telephone:  
847-679-8833  
Facsimile:  
847-679-8849

**Glenair Nordic AB**

Gustav III : S Boulevard 46  
S - 169 27 Solna  
Sweden

Telephone:  
+46-8-50550000  
Facsimile:  
+46-8-50550001  
sales@glenair.se

**Glenair Electric GmbH**

Siemensstrasse 9  
D-61449 Steinbach  
Germany

Telephone:  
49-6171-5905-0  
Facsimile:  
49-6171-5905-90  
germany@glenair.com

**Glenair Iberica**

C/ La Vega, 16  
45612 Velada  
Spain

Telephone:  
+34-925-89-29-88  
Facsimile:  
+34-925-89-29-87  
sales@glenair.es

**Glenair Italia S.p.A.**

Via Del Lavoro, 7  
40057 Quarto Inferiore –  
Granarolo dell'Emilia  
Bologna, Italy

Telephone:  
+39-051-782811  
Facsimile:  
+39-051-782259  
info@glenair.it

**Glenair France SARL**

7, Avenue Parmentier  
Immeuble Central Parc #2  
31200 Toulouse  
France

Telephone:  
+33-5-34-40-97-40  
Facsimile:  
+33-5-61-47-86-10  
sales@glenair.fr

